



**FOLDABLE COMBO MEDICAL ARMS
FOR DISPLAY, KEYBOARD AND MOUSE
WALL MOUNTING**



We have all the solutions and offer you the widest choice of professional medical systems and supports compatible with the widest possible range of medical displays and keyboards.



Our Medical Arms Combo for Screen, Keyboard, Mouse Wall Mount

MEDICAL ARMS COMBO (SCREEN / KEYBOARD / MOUSE) WALL MOUNTING

MEDICAL ARM COMBO FOLDABLE (Wall Mount)

INDEX :

Medical Arms Combo for Screen, Keyboard, Mouse Wall Mount

Medical Arms Combo for Screen, Keyboard, Mouse Wall Mount Overview	Page 4 - 23
Mandatory accessories overview	Page 24
Optional Accessories Overview	Page 25 - 28
Medical Arms Combo for Screen, Keyboard, Mouse Wall Mount Presentations and Technical Sheets.....	Page 29 -140
Mandatory Accessories Presentations and Technical Data Sheets	Page 141 - 148
Optional Accessories Presentations and Data Sheets	Page 149 - 198
Les Avantages des Bras Médicaux	Page 199 - 206





Our Medical Arms Combo for Screen, Keyboard, Mouse Wall Mount

MEDICAL ARMS COMBO (SCREEN / KEYBOARD / MOUSE) WALL MOUNTING

MEDICAL ARM COMBO FOLDABLE (Wall Mount)

Orient and position your screen, keyboard and mouse effortlessly from the wall

This range of products has been designed to meet all the needs for fixing a flat screen with its keyboard and mouse that many users in the healthcare sector.

The Combo Medical Arms for Monitor, Keyboard and Mouse help create a larger, quieter, more ergonomic and individual medical workstation.

However, Combo medical arms are not all identical. We offer several types of medical Combo arms in several series each of which is intended for a specific application: depth adjustment, height adjustment or simply both.

We assist you in choosing the Medical Combo Monitor / Keyboard / Mouse Arm that best suits your needs. Position your LCD screen at the height appropriate for your viewing comfort.

We have all the solutions and offer the widest choice of professional medical media systems compatible with the widest possible range of medical and computer displays.

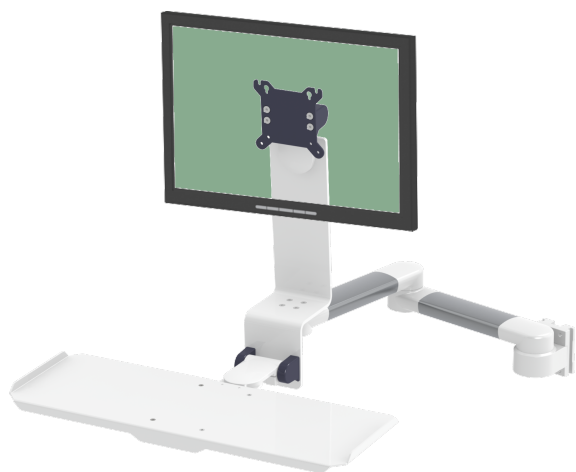

Medical Arms Combo for Screen, Keyboard, Mouse Wall Mount

Medical Arms Combo Foldable and adjustable in height, wall rail mounting

OVERVIEW



Medical Arm Combo Foldable and adjustable in height 300 mm wall mount

Part Number: 991.683-1-1

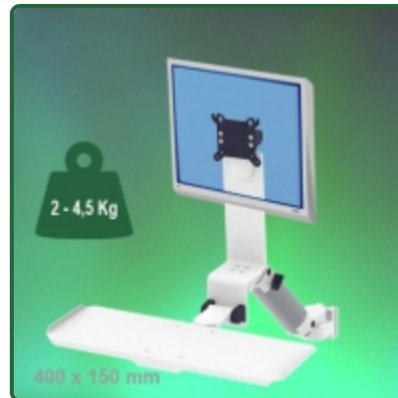

Medical Arm Combo Foldable and adjustable in height 300 mm wall mount

Part Number: 991.683-1-2



Medical Arm Combo Foldable and adjustable in height 300 mm wall mount

Part Number: 991.683-1-3

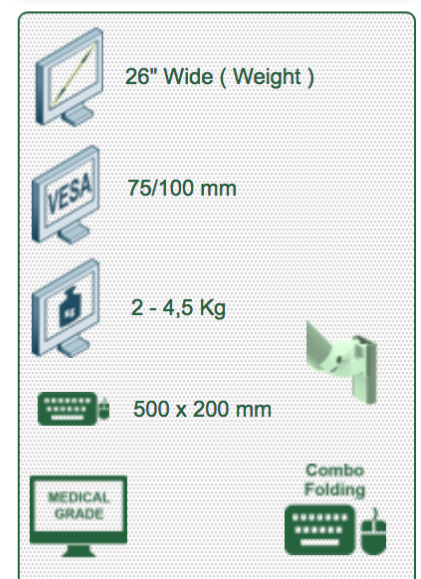

Medical Arms Combo for Screen, Keyboard, Mouse Wall Mount

Medical Arms Combo Foldable and adjustable in height, wall rail mounting

OVERVIEW



Medical Arm Combo Foldable and adjustable in height 300 mm wall mount

Part Number: 991.683-1-4



Medical Arm Combo Foldable and adjustable in height 300 mm wall mount

Part Number: 991.683-2-1



Medical Arm Combo Foldable and adjustable in height 300 mm wall mount

Part Number: 991.683-2-2

26" Wide (Weight)

VESA 75/100 mm

2 - 4,5 Kg

580 x 200 mm

MEDICAL GRADE

Combo Folding

26" Wide (Weight)

VESA 75/100 mm

3 - 7 Kg

300 x 210 mm

MEDICAL GRADE

Combo Folding

26" Wide (Weight)

VESA 75/100 mm

3 - 7 Kg

400 x 150 mm

MEDICAL GRADE

Combo Folding

Medical Arms Combo for Screen, Keyboard, Mouse Wall Mount

Medical Arms Combo Foldable and adjustable in height, wall rail mounting

OVERVIEW



Medical Arm Combo Foldable and adjustable in height 300 mm wall mount

Part Number: 991.683-2-3



Medical Arm Combo Foldable and adjustable in height 300 mm wall mount

Part Number: 991.683-2-4

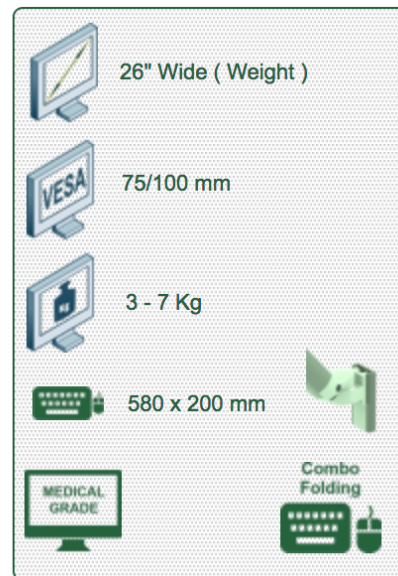

Medical Arm Combo Foldable and adjustable in height 300 mm wall mount

Part Number: 991.683-3-1

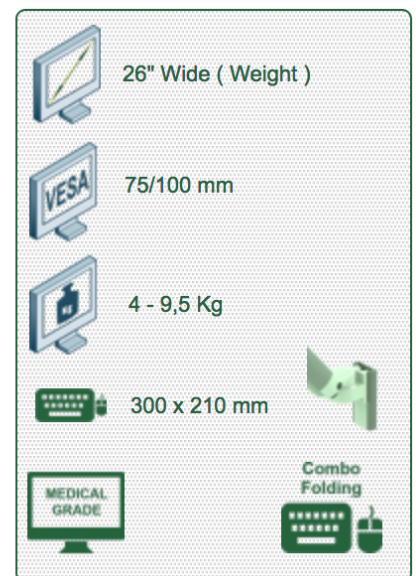

Medical Arms Combo for Screen, Keyboard, Mouse Wall Mount

Medical Arms Combo Foldable and adjustable in height, wall rail mounting

OVERVIEW



Medical Arm Combo Foldable and adjustable in height 300 mm wall mount

Part Number: 991.683-3-2

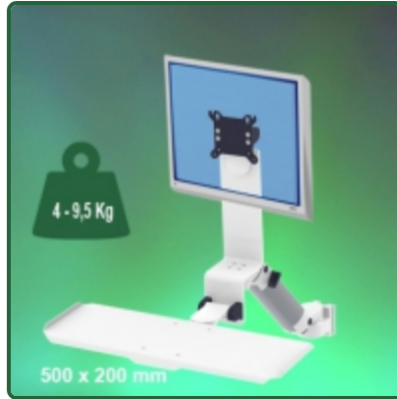

Medical Arm Combo Foldable and adjustable in height 300 mm wall mount

Part Number: 991.683-3-3



Medical Arm Combo Foldable and adjustable in height 300 mm wall mount

Part Number: 991.683-3-4

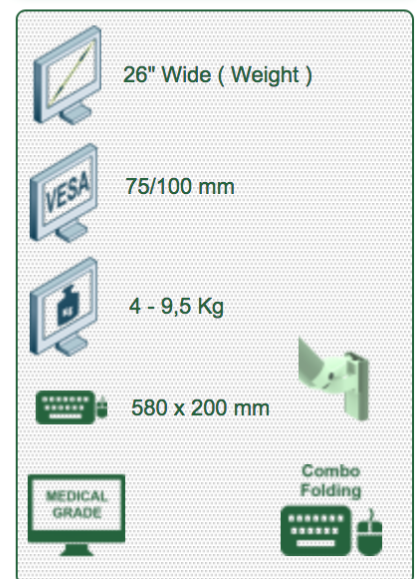
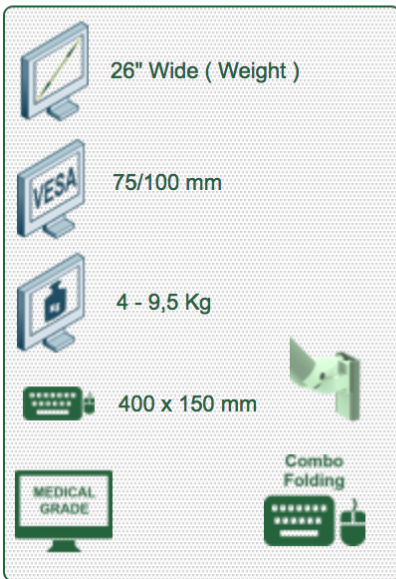

Medical Arms Combo for Screen, Keyboard, Mouse Wall Mount

Medical Arms Combo Foldable and adjustable in height, wall rail mounting

OVERVIEW



Medical Arm Combo Foldable and adjustable in height 300 mm wall mount

Part Number: 991.683-4-1



Medical Arm Combo Foldable and adjustable in height 300 mm wall mount

Part Number: 991.683-4-2



Medical Arm Combo Foldable and adjustable in height 300 mm wall mount

Part Number: 991.683-4-3

26" Wide (Weight)

VESA 75/100 mm

10 - 11,5 Kg

300 x 210 mm

MEDICAL GRADE

Combo Folding

26" Wide (Weight)

VESA 75/100 mm

10 - 11,5 Kg

400 x 150 mm

MEDICAL GRADE

Combo Folding

26" Wide (Weight)

VESA 75/100 mm

10 - 11,5 Kg

500 x 200 mm

MEDICAL GRADE

Combo Folding

Medical Arms Combo for Screen, Keyboard, Mouse Wall Mount

Medical Arms Combo Foldable and adjustable in height, wall rail mounting

OVERVIEW



Medical Arm Combo Foldable and adjustable in height 300 mm wall mount

Part Number: 991.683-4-4



Medical Arm Combo Foldable and adjustable in height 300 mm wall mount

Part Number: 991.683-5-1



Medical Arm Combo Foldable and adjustable in height 300 mm wall mount

Part Number: 991.683-5-2

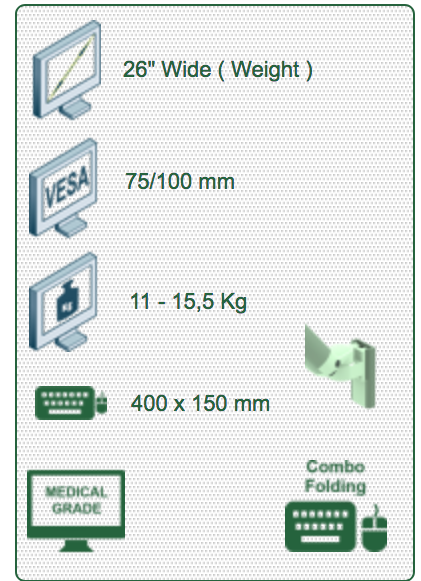

Medical Arms Combo for Screen, Keyboard, Mouse Wall Mount

Medical Arms Combo Foldable and adjustable in height, wall rail mounting

OVERVIEW



Medical Arm Combo Foldable and adjustable in height 300 mm wall mount

Part Number: 991.683-5-3



Medical Arm Combo Foldable and adjustable in height 300 mm wall mount

Part Number: 991.683-5-4



Medical Arm Combo Foldable and adjustable in height 300 + 240 mm wall mount

Part Number: 991.692-1-1

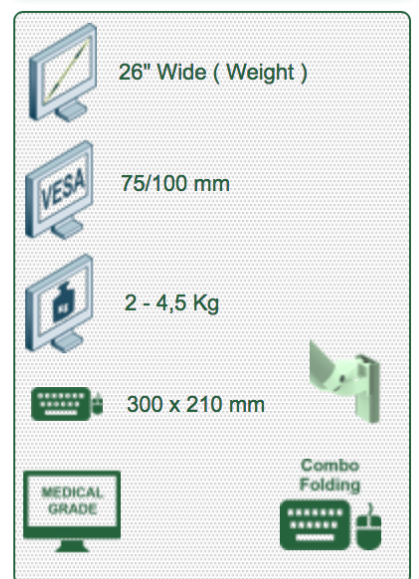
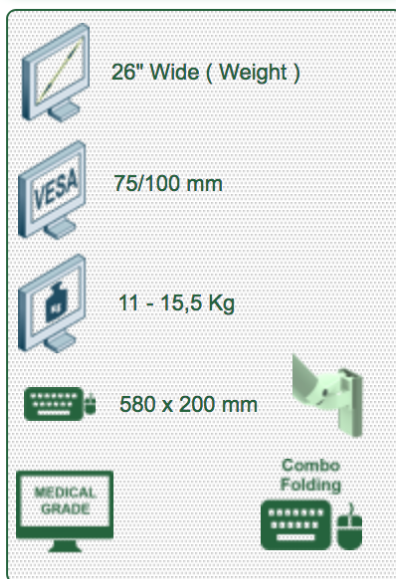

Medical Arms Combo for Screen, Keyboard, Mouse Wall Mount

Medical Arms Combo Foldable and adjustable in height, wall rail mounting

OVERVIEW



Medical Arm Combo Foldable and adjustable in height 300 + 240 mm wall mount

Part Number: 991.692-1-2



Medical Arm Combo Foldable and adjustable in height 300 + 240 mm wall mount

Part Number: 991.692-1-3



Medical Arm Combo Foldable and adjustable in height 300 + 240 mm wall mount

Part Number: 991.692-1-4

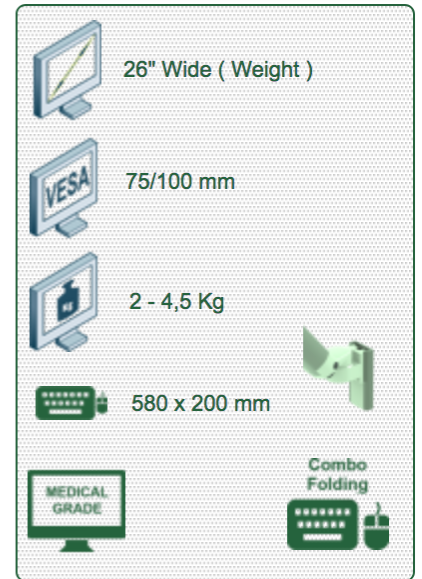

Medical Arms Combo for Screen, Keyboard, Mouse Wall Mount

Medical Arms Combo Foldable and adjustable in height, wall rail mounting

OVERVIEW



Medical Arm Combo Foldable and adjustable in height 300 + 240 mm wall mount

Part Number: 991.692-2-1



Medical Arm Combo Foldable and adjustable in height 300 + 240 mm wall mount

Part Number: 991.692-2-2



Medical Arm Combo Foldable and adjustable in height 300 + 240 mm wall mount

Part Number: 991.692-2-3

26" Wide (Weight)

VESA 75/100 mm

3 - 7 Kg

300 x 210 mm

MEDICAL GRADE

Combo Folding

26" Wide (Weight)

VESA 75/100 mm

3 - 7 Kg

400 x 150 mm

MEDICAL GRADE

Combo Folding

26" Wide (Weight)

VESA 75/100 mm

3 - 7 Kg

500 x 200 mm

MEDICAL GRADE

Combo Folding

Medical Arms Combo for Screen, Keyboard, Mouse Wall Mount

Medical Arms Combo Foldable and adjustable in height, wall rail mounting

OVERVIEW



Medical Arm Combo Foldable and adjustable in height 300 + 240 mm wall mount

Part Number: 991.692-2-4



Medical Arm Combo Foldable and adjustable in height 300 + 240 mm wall mount

Part Number: 991.692-3-1



Medical Arm Combo Foldable and adjustable in height 300 + 240 mm wall mount

Part Number: 991.692-3-2

26" Wide (Weight)

VESA 75/100 mm

3 - 7 Kg

580 x 200 mm

MEDICAL GRADE

Combo Folding

26" Wide (Weight)

VESA 75/100 mm

4 - 9,5 Kg

300 x 210 mm

MEDICAL GRADE

Combo Folding

26" Wide (Weight)

VESA 75/100 mm

4 - 9,5 Kg

400 x 150 mm

MEDICAL GRADE

Combo Folding

Medical Arms Combo for Screen, Keyboard, Mouse Wall Mount

Medical Arms Combo Foldable and adjustable in height, wall rail mounting

OVERVIEW



Medical Arm Combo Foldable and adjustable in height 300 + 240 mm wall mount

Part Number: 991.692-3-3



Medical Arm Combo Foldable and adjustable in height 300 + 240 mm wall mount

Part Number: 991.692-3-4



Medical Arm Combo Foldable and adjustable in height 300 + 240 mm wall mount

Part Number: 991.692-4-1

26" Wide (Weight)

VESA 75/100 mm

4 - 9,5 Kg

500 x 200 mm

MEDICAL GRADE

Combo Folding

26" Wide (Weight)

VESA 75/100 mm

4 - 9,5 Kg

580 x 200 mm

MEDICAL GRADE

Combo Folding

26" Wide (Weight)

VESA 75/100 mm

10 - 11,5 Kg

300 x 210 mm

MEDICAL GRADE

Combo Folding

Medical Arms Combo for Screen, Keyboard, Mouse Wall Mount

Medical Arms Combo Foldable and adjustable in height, wall rail mounting

OVERVIEW



Medical Arm Combo Foldable and adjustable in height 300 + 240 mm wall mount

Part Number: 991.692-4-2



Medical Arm Combo Foldable and adjustable in height 300 + 240 mm wall mount

Part Number: 991.692-4-3



Medical Arm Combo Foldable and adjustable in height 300 + 240 mm wall mount

Part Number: 991.692-4-4

- 26" Wide (Weight)
- 75/100 mm
- 10 - 11,5 Kg
- 400 x 150 mm
- MEDICAL GRADE
- Combo Folding

- 26" Wide (Weight)
- 75/100 mm
- 10 - 11,5 Kg
- 500 x 200 mm
- MEDICAL GRADE
- Combo Folding

- 26" Wide (Weight)
- 75/100 mm
- 10 - 11,5 Kg
- 580 x 200 mm
- MEDICAL GRADE
- Combo Folding

Medical Arms Combo for Screen, Keyboard, Mouse Wall Mount

Medical Arms Combo Foldable and adjustable in height, wall rail mounting

OVERVIEW



Medical Arm Combo Foldable and adjustable in height 300 + 240 mm wall mount

Part Number: 991.692-5-1



Medical Arm Combo Foldable and adjustable in height 300 + 240 mm wall mount

Part Number: 991.692-5-2



Medical Arm Combo Foldable and adjustable in height 300 + 240 mm wall mount

Part Number: 991.692-5-3

26" Wide (Weight)

VESA 75/100 mm

11 - 15,5 Kg

300 x 210 mm

MEDICAL GRADE

Combo Folding

26" Wide (Weight)

VESA 75/100 mm

11 - 15,5 Kg

400 x 150 mm

MEDICAL GRADE

Combo Folding

26" Wide (Weight)

VESA 75/100 mm

11 - 15,5 Kg

500 x 200 mm

MEDICAL GRADE

Combo Folding

Medical Arms Combo for Screen, Keyboard, Mouse Wall Mount

Medical Arms Combo Foldable and adjustable in height, wall rail mounting

OVERVIEW



Medical Arm Combo Foldable and adjustable in height 300 + 240 mm wall mount

Part Number: 991.692-5-4

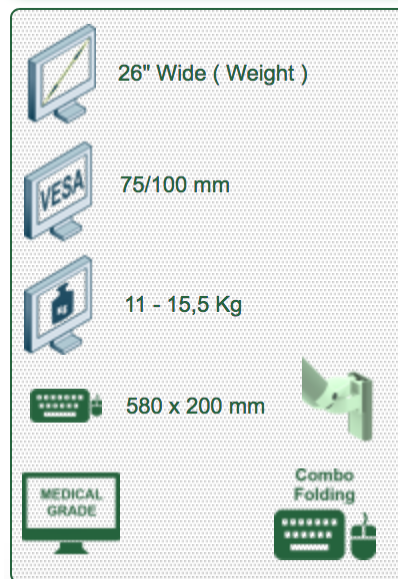

Medical Arms Combo for Screen, Keyboard, Mouse Wall Mount Medical Arms Combo Foldable and Adjustable Depth Wall Rail Mount OVERVIEW



Medical Arm Combo Foldable and adjustable in depth, 240 mm, wall mounting
Part Number: 991.657-1



Medical Arm Combo Foldable and adjustable in depth, 240 mm, wall mounting
Part Number: 991.657-2



Medical Arm Combo Foldable and adjustable in depth, 240 mm, wall mounting
Part Number: 991.657-3

26" Wide (Weight)

VESA 75/100 mm

18 Kg

300 x 210 mm

MEDICAL GRADE

Combo Folding

26" Wide (Weight)

VESA 75/100 mm

18 Kg

400 x 150 mm

MEDICAL GRADE

Combo Folding

26" Wide (Weight)

VESA 75/100 mm

18 Kg

500 x 200 mm

MEDICAL GRADE

Combo Folding

Medical Arms Combo for Screen, Keyboard, Mouse Wall Mount Medical Arms Combo Foldable and Adjustable Depth Wall Rail Mount OVERVIEW









Medical Arm Combo Foldable and adjustable in depth, 240 mm, wall mounting
Part Number: 991.657-4









Medical Arm Combo Foldable and adjustable in depth, 300 mm, wall mounting
Part Number: 991.658-1

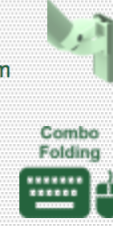

Medical Arm Combo Foldable and adjustable in depth, 300 mm, wall mounting
Part Number: 991.658-2

-  26" Wide (Weight)
-  75/100 mm
-  18 Kg
-  580 x 200 mm
-  MEDICAL GRADE
-  Combo Folding

-  26" Wide (Weight)
-  75/100 mm
-  18 Kg
-  300 x 210 mm
-  MEDICAL GRADE
-  Combo Folding

-  26" Wide (Weight)
-  75/100 mm
-  18 Kg
-  400 x 150 mm
-  MEDICAL GRADE
-  Combo Folding

Medical Arms Combo for Screen, Keyboard, Mouse Wall Mount

Medical Arms Combo Foldable and Adjustable Depth Wall Rail Mount

OVERVIEW



Medical Arm Combo Foldable and adjustable in depth, 300 mm, wall mounting

Part Number: 991.658-3



Medical Arm Combo Foldable and adjustable in depth, 300 mm, wall mounting

Part Number: 991.658-4



Medical Arm Combo Foldable and adjustable in depth, 2 x 240 mm, wall mounting

Part Number: 991.671-1

26" Wide (Weight)

VESA 75/100 mm

18 Kg

500 x 200 mm

MEDICAL GRADE

Combo Folding

26" Wide (Weight)

VESA 75/100 mm

18 Kg

580 x 200 mm

MEDICAL GRADE

Combo Folding

26" Wide (Weight)

VESA 75/100 mm

15 Kg

300 x 210 mm

MEDICAL GRADE

Combo Folding

Medical Arms Combo for Screen, Keyboard, Mouse Wall Mount

Medical Arms Combo Foldable and Adjustable Depth Wall Rail Mount

OVERVIEW



Medical Arm Combo Foldable and adjustable in depth, 2 x 240 mm, wall mounting

Part Number: 991.671-2



Medical Arm Combo Foldable and adjustable in depth, 2 x 240 mm, wall mounting

Part Number: 991.671-3



Medical Arm Combo Foldable and adjustable in depth, 2 x 240 mm, wall mounting

Part Number: 991.671-4

26" Wide (Weight)

VESA 75/100 mm

15 Kg

400 x 150 mm

MEDICAL GRADE

Combo Folding

26" Wide (Weight)

VESA 75/100 mm

15 Kg

500 x 200 mm

MEDICAL GRADE

Combo Folding

26" Wide (Weight)

VESA 75/100 mm

15 Kg

580 x 200 mm

MEDICAL GRADE

Combo Folding

Medical Arms Combo for Screen, Keyboard, Mouse Wall Mount

Medical Arms Combo Foldable and Adjustable Depth Wall Rail Mount

OVERVIEW



Medical Arm Combo Foldable and adjustable in depth, 2 x 300 mm, wall mounting







Part Number: 991.672-1

-  26" Wide (Weight)
-  75/100 mm
-  12,5 Kg
-  300 x 210 mm
-  MEDICAL GRADE
-  Combo Folding
- 



Medical Arm Combo Foldable and adjustable in depth, 2 x 300 mm, wall mounting







Part Number: 991.672-2

-  26" Wide (Weight)
-  75/100 mm
-  12,5 Kg
-  400 x 150 mm
-  MEDICAL GRADE
-  Combo Folding
- 



Medical Arm Combo Foldable and adjustable in depth, 2 x 300 mm, wall mounting

Part Number: 991.672-3

-  26" Wide (Weight)
-  75/100 mm
-  12,5 Kg
-  500 x 200 mm
-  MEDICAL GRADE
-  Combo Folding
- 

Medical Arms Combo for Screen, Keyboard, Mouse Wall Mount Medical Arms Combo Foldable and Adjustable Depth Wall Rail Mount OVERVIEW



Medical Arm Combo Foldable and adjustable in depth, 2 x 300 mm, wall mounting

Part Number: 991.672-4

26" Wide (Weight)

VESA 75/100 mm

12,5 Kg

580 x 200 mm

MEDICAL GRADE

Combo Folding

Medical Arms Combo for Screen, Keyboard, Mouse Wall Mount Mandatory Accessories OVERVIEW

Mandatory Accessories :



Vertical Sliding Wall Rail
480 mm

Part Number: 999.145

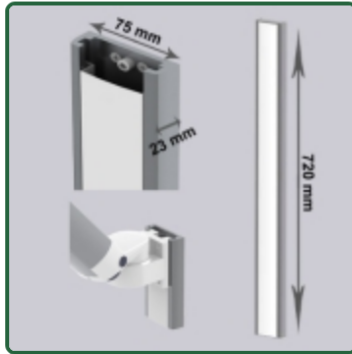

Vertical Sliding Wall Rail
720 mm

Part Number: 999.146

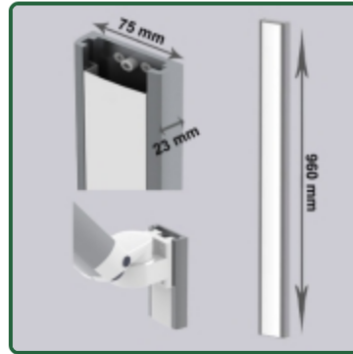

Vertical Sliding Wall Rail
960 mm

Part Number: 999.147



Vertical Sliding Wall Rail
1200 mm

Part Number: 999.148

Medical Arms Combo for Screen, Keyboard, Mouse Wall Mount

Optional Accessories

OVERVIEW

Optional Accessories :

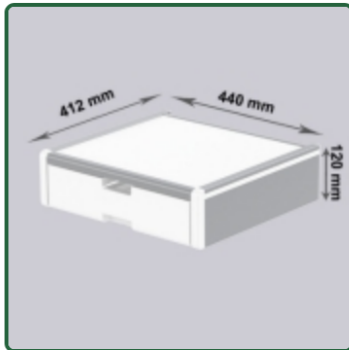

Single drawer, Vertical Slide Rail Mounting
Part Number: 999.149



Din Rail 10 x 25 mm. Length 300 mm.
Part Number: 999.150

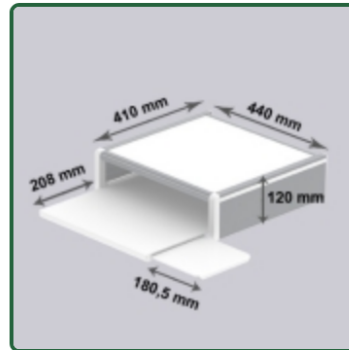

Drawer and Keyboard Stand Vertical Slide Rail Mounting
Part Number: 999.151

If you don't find the right accessory for you, do not hesitate to contact us, we will help you in your search



HD worktop, Vertical Slide Rail Mounting
Part Number: 999.153

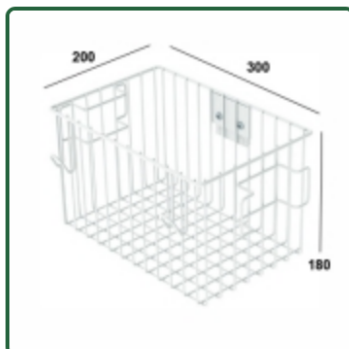

Large service basket, vertical slide rail mounting
Part Number: 999.154

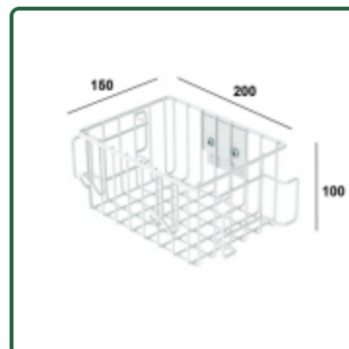

Small service basket, vertical slide rail mounting
Part Number: 999.155

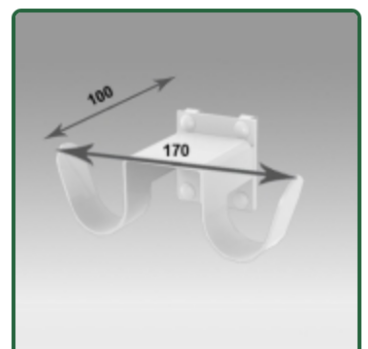

Double cable hooks for vertical slide rail mounting
Part Number: 999.156

Medical Arms Combo for Screen, Keyboard, Mouse Wall Mount

Optional Accessories

OVERVIEW

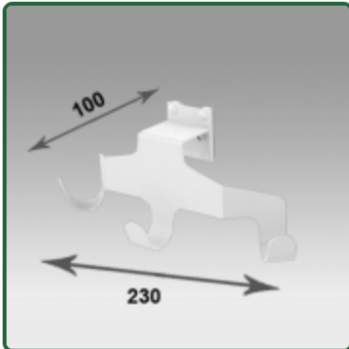

Triple cable hooks for vertical slide rail mounting

Part Number: 999.157

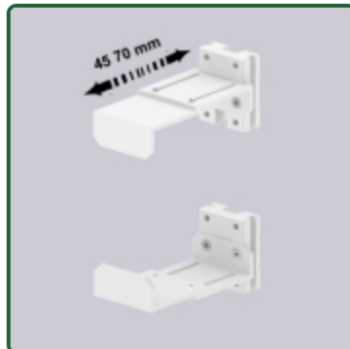

CPU Holder Adjustable 45-70 mm for vertical slide rail mounting

Part Number: 999.158

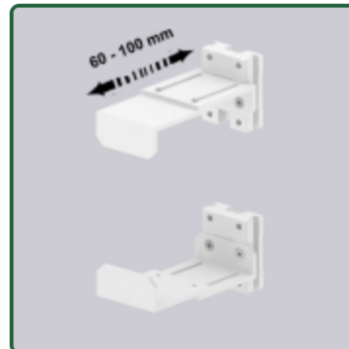

CPU Holder Adjustable 60-100 mm for vertical slide rail mounting glissière

Part Number: 999.159



CPU Holder Adjustable 85-150 mm for vertical slide rail mounting glissière

Part Number: 999.160



CPU Holder Adjustable 130-170 mm for vertical slide rail mounting

Part Number: 999.161

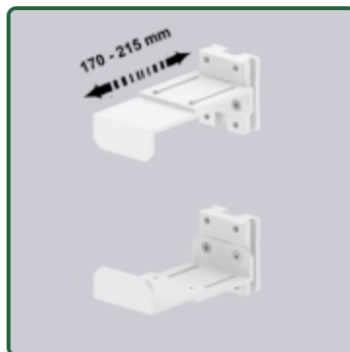

CPU Holder Adjustable 170-215 mm for vertical slide rail mounting

Part Number: 999.162

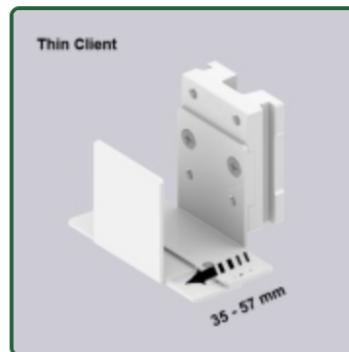

Universal Stand Adjustable 35-57 mm on vertical slide rail mounting

Part Number: 999.163

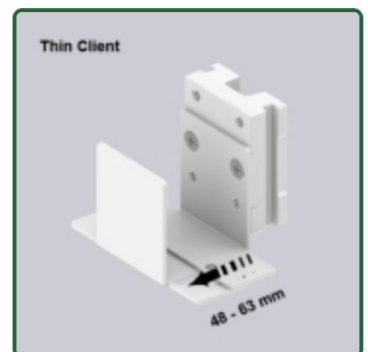

Universal Stand Adjustable 48-63 mm on vertical slide rail mounting

Part Number: 999.164

Medical Arms Combo for Screen, Keyboard, Mouse Wall Mount

Optional Accessories

OVERVIEW

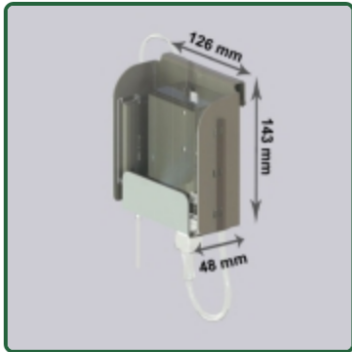

Power Supply Stand, Vertical slide rail mounting

Part Number: 999.165

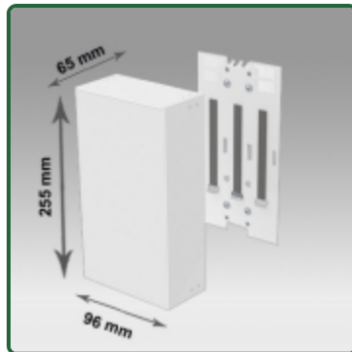

Electrical power supply box 255 x 96 x 65 mm

Part Number: 999.166

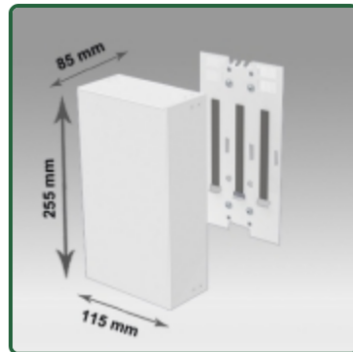

Electrical power supply box 255 x 115 x 85 mm

Part Number: 999.167

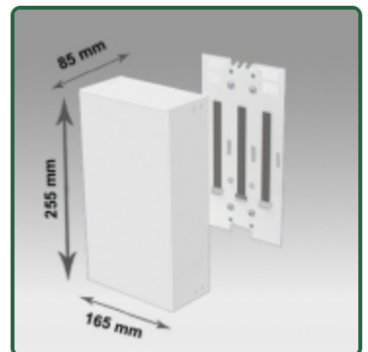

Electrical power supply box 255 x 165 x 85 mm

Part Number: 999.168

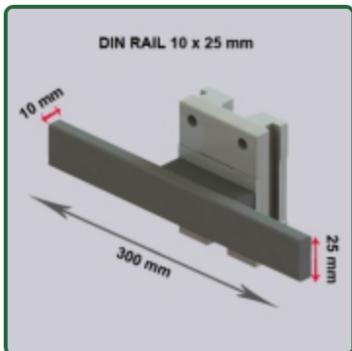

Din Rail 10 x 25 mm. Length 300 mm on vertical rail

Part Number: 999.169

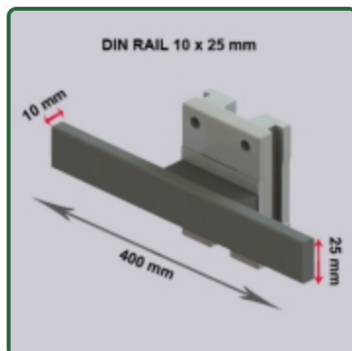

Din Rail 10 x 25 mm. Length 400 mm on vertical rail

Part Number: 999.170

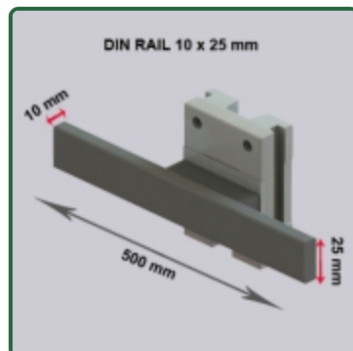

Din Rail 10 x 25 mm. Length 500 mm on vertical rail

Part Number: 999.171



Holder for 1 Medical Gas Bottle Vertical Rail Mounting

Part Number: 999.172

Medical Arms Combo for Screen, Keyboard, Mouse Wall Mount
Optional Accessories
OVERVIEW



Holder for 2 Medical Gas
Bottle Vertical Rail Mounting

Part Number: 999.173

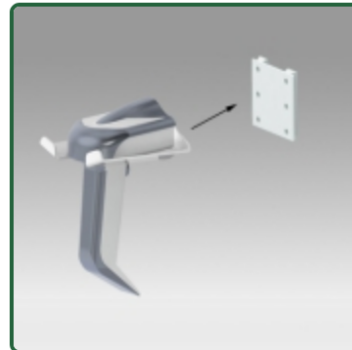

Holder for barcode hand
shower

Part Number: 999.174

300 mm height-adjustable Medical Combo Folding Arm for monitor, keyboard and mouse, wall mounting on vertical sliding rail

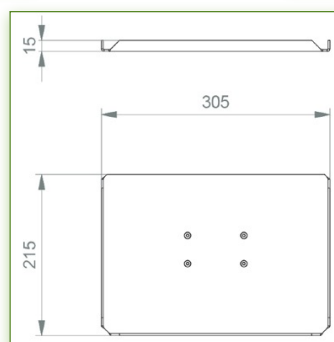
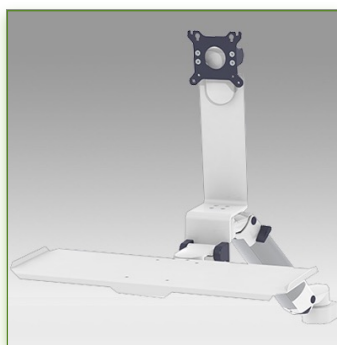

Display Compatibility: 26" Wide (Weight)
Supported Weight: 2- 4,5 Kg
VESA standard: 75 / 100 mm
Keyboard-Mouse holder: 300 x 210 mm

 Up to 26" Wide (Weight)
 75/100 mm
 2 - 4,5 Kg
 300 x 210 mm
 MEDICAL GRADE
 Combo Folding

Do not hesitate to contact us if you have any questions about this product.

Warranty: 5 years

000.991.683-1-1

Graphite Grey and White

On Measure

= Depending on the elements

991.683-1-1

300 mm height-adjustable Medical Combo Folding Arm for monitor, keyboard and mouse, wall mounting on vertical sliding rail

This 300 mm Folding Combo Medical Arm with gas spring height adjustment allows the LCD screen to be perfectly fixed, oriented and adjusted and supports the keyboard and mouse. It is coated with an anti-microbial agent offering hygiene and cleaning down to the last detail. Its modern design has been specially designed for healthcare environments.

Technical specifications:

- * Integrated cable channel
- * Equipotential bonding
- * Optional Vertical Wall Slide Rail Mounting available in several lengths (480 mm - 720 mm - 960 mm - 1200 mm).
- * These wall rails can be easily cut to the required size. All cables also pass through the wall rail. (See Options below)
- * This 300 mm Combo Folding Arm with gas spring simply slides into the wall rail to adjust to the desired height and fixed.
- * It has a safety height adjustment stop button, which allows the arm to remain in the chosen position.
- * The head of this arm complies with the standard for mounting screens: VESA MIS-D 75 mm and 100 mm.
- * Compatible with screens whose weight does not exceed 2 - 4,5 Kg.
- * Touch screen stability. * Screen tilt: 10°.
- * Screen rotation: 110° right, 110° left.
- * Arm rotation: 105° to the right, 105° to the left.
- * Height adjustment: 45° down, 45° up * Total length 821-916 mm
- * Foldable and removable keyboard and mouse holder: 300 x 210 mm
- * Compatible with multimedia terminals (TMM)
- * Color RAL 7024 (Graphite Grey) and White
- * All our medical arms are in conformity: CE, ROHS, Medical Grade, Regulations MDD 93/42 ECC.
- * Warranty: 5 years

Note: This arm can also be installed on one of our medical columns or trolleys.

Part Number: 991.683-1-1 - Technical Sheet
300 mm height-adjustable Medical Combo Folding Arm for monitor, keyboard and mouse, wall mounting on vertical sliding rail

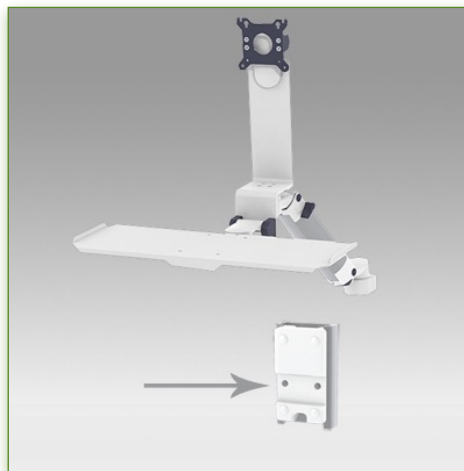

Display Compatibility: 26" Wide (Weight)
 Supported Weight: 2- 4,5 Kg
 VESA standard: 75 / 100 mm
 Keyboard-Mouse holder: 300 x 210 mm

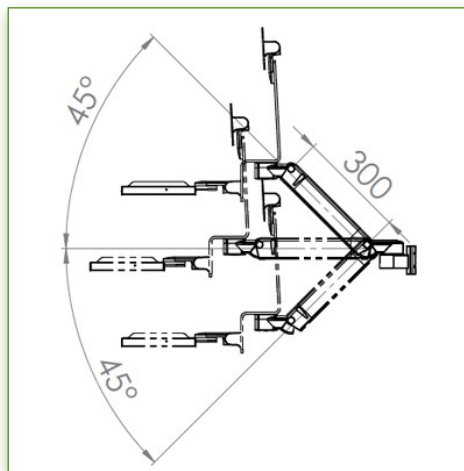
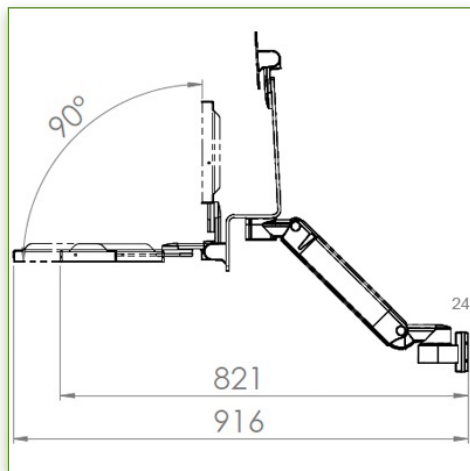
 Up to 26" Wide (Weight)
 75/100 mm
 2- 4,5 Kg
 300 x 210 mm
Medical Grade

Do not hesitate to contact us if you have any questions about this product.

Warranty: 5 years

000.991.683-1-1

Graphite Grey and White

On Measure

= Depending on the elements

991.683-1-1

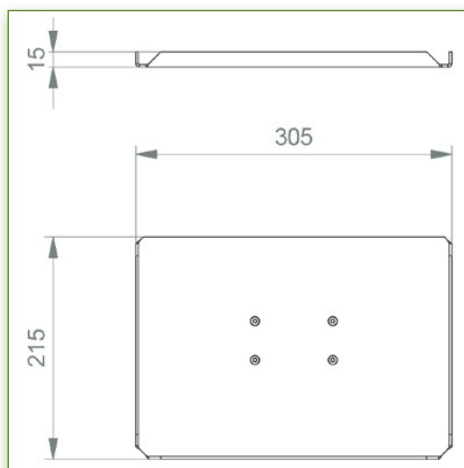
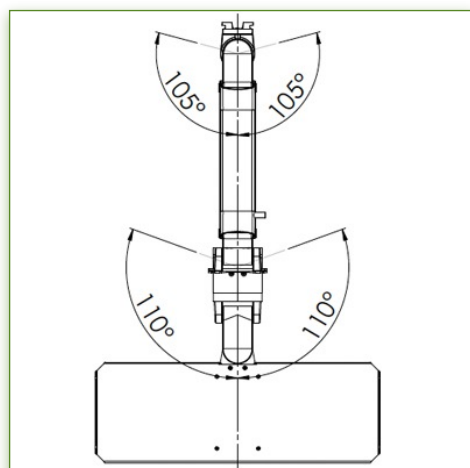

Anti-bacterial properties:

IT medical arms are now designed with Microban antibacterial protection, a revolutionary treatment that guarantees optimal hygiene. IT medical arms integrate Microban and other antibacterial agents into all medical products. It inhibits the growth of bacteria of all types. This is not a surface treatment. It is 100% in the totality of the product. It does not alter the physico-mechanical properties of the medical arm lift system. Simulations over 30 years show that 100% of the antibacterial properties are maintained. All medical articulated arms incorporate Microban. Microban is the world's leading provider of anti-bacterial solutions. It has been successfully applied for more than 35 years in a wide range of products used in the hospital, construction and food industries.

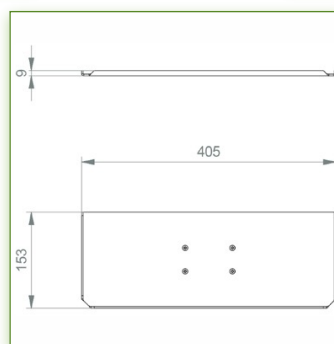
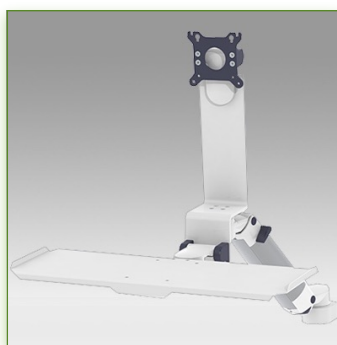

Display Compatibility: 26" Wide (Weight)
Supported Weight: 2- 4,5 Kg
VESA standard: 75 / 100 mm
Keyboard-Mouse holder: 400 x 150 mm

 Up to 26" Wide (Weight)
 75/100 mm
 2 - 4,5 Kg
 400 x 150 mm
 MEDICAL GRADE
 Combo Folding

Do not hesitate to contact us if you have any questions about this product.

Warranty: 5 years

000.991.683-1-2

Graphite Grey and White

On Measure

= Depending on the elements

991.683-1-2

300 mm height-adjustable Medical Combo Folding Arm for monitor, keyboard and mouse, wall mounting on vertical sliding rail

This 300 mm Folding Combo Medical Arm with gas spring height adjustment allows the LCD screen to be perfectly fixed, oriented and adjusted and supports the keyboard and mouse. It is coated with an anti-microbial agent offering hygiene and cleaning down to the last detail. Its modern design has been specially designed for healthcare environments.

Technical specifications:

- * Integrated cable channel
- * Equipotential bonding
- * Optional Vertical Wall Slide Rail Mounting available in several lengths (480 mm - 720 mm - 960 mm - 1200 mm).
- * These wall rails can be easily cut to the required size. All cables also pass through the wall rail. (See Options below)
- * This 300 mm Combo Folding Arm with gas spring simply slides into the wall rail to adjust to the desired height and fixed.
- * It has a safety height adjustment stop button, which allows the arm to remain in the chosen position.
- * The head of this arm complies with the standard for mounting screens: VESA MIS-D 75 mm and 100 mm.
- * Compatible with screens whose weight does not exceed 2 - 4,5 Kg.
- * Touch screen stability. * Screen tilt: 10°.
- * Screen rotation: 110° right, 110° left.
- * Arm rotation: 105° to the right, 105° to the left.
- * Height adjustment: 45° down, 45° up * Total length 821-916 mm
- * Foldable and removable keyboard and mouse holder: 400 x 150 mm
- * Compatible with multimedia terminals (TMM)
- * Color RAL 7024 (Graphite Grey) and White
- * All our medical arms are in conformity: CE, ROHS, Medical Grade, Regulations MDD 93/42 ECC.
- * Warranty: 5 years

Note: This arm can also be installed on one of our medical columns or trolleys.

300 mm height-adjustable Medical Combo Folding Arm for monitor, keyboard and mouse, wall mounting on vertical sliding rail



Display Compatibility: 26" Wide (Weight)
Supported Weight: 2- 4,5 Kg
VESA standard: 75 / 100 mm
Keyboard-Mouse holder: 400 x 150 mm

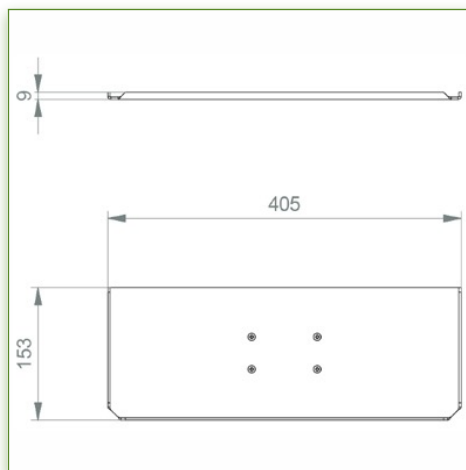
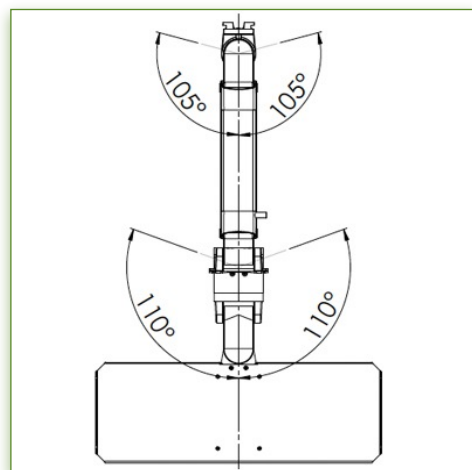
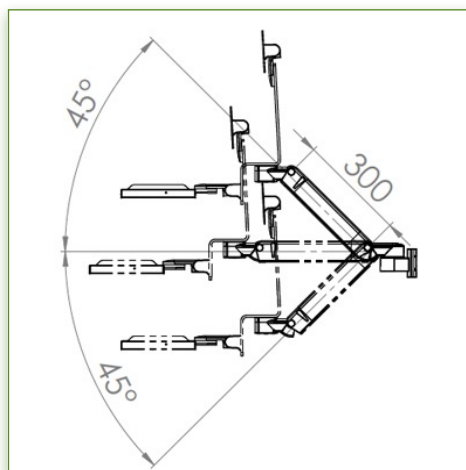
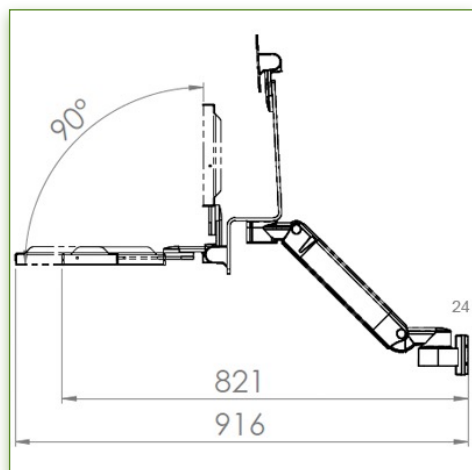
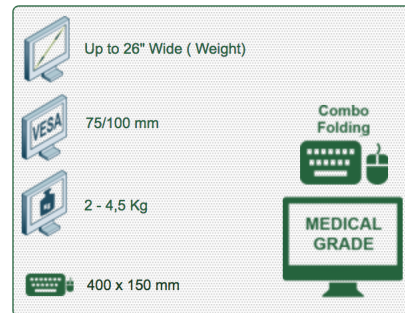

Do not hesitate to contact us if you have any questions about this product.

Warranty: 5 years

000.991.683-1-2

Graphite Grey and White

On Measure

= Depending on the elements

991.683-1-2

Anti-bacterial properties:

IT medical arms are now designed with Microban antibacterial protection, a revolutionary treatment that guarantees optimal hygiene. IT medical arms integrate Microban and other antibacterial agents into all medical products. It inhibits the growth of bacteria of all types. This is not a surface treatment.

It is 100% in the totality of the product. It does not alter the physico-mechanical properties of the medical arm lift system. Simulations over 30 years show that 100% of the antibacterial properties are maintained.

All medical articulated arms incorporate Microban. Microban is the world's leading provider of anti-bacterial solutions. It has been successfully applied for more than 35 years in a wide range of products used in the hospital, construction and food industries.

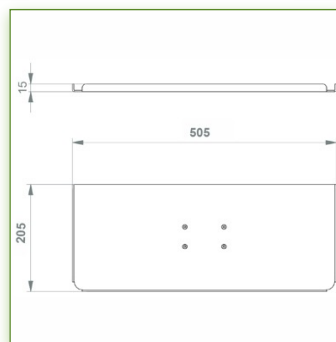
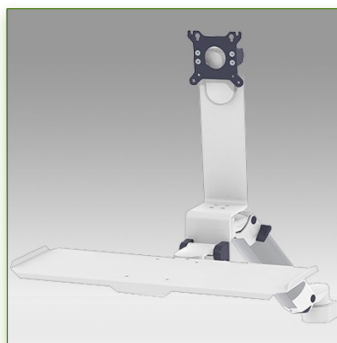
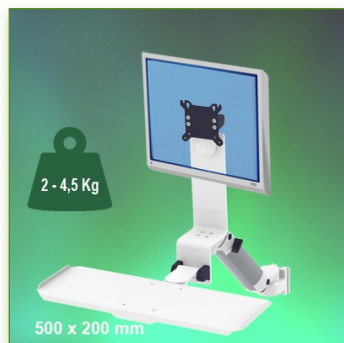

Display Compatibility: 26" Wide (Weight)
Supported Weight: 2- 4,5 Kg
VESA standard: 75 / 100 mm
Keyboard-Mouse holder: 500 x 200 mm

 Up to 26" Wide (Weight)
 75/100 mm
 2 - 4,5 Kg
 500 x 200 mm
 MEDICAL GRADE
 Combo Folding

Do not hesitate to contact us if you have any questions about this product.



Warranty: 5 years



000.991.683-1-3



Graphite Grey and White



On Measure



= Depending on the elements



991.683-1-3

300 mm height-adjustable Medical Combo Folding Arm for monitor, keyboard and mouse, wall mounting on vertical sliding rail

This 300 mm Folding Combo Medical Arm with gas spring height adjustment allows the LCD screen to be perfectly fixed, oriented and adjusted and supports the keyboard and mouse. It is coated with an anti-microbial agent offering hygiene and cleaning down to the last detail. Its modern design has been specially designed for healthcare environments.

Technical specifications:

- * Integrated cable channel
- * Equipotential bonding
- * Optional Vertical Wall Slide Rail Mounting available in several lengths (480 mm - 720 mm - 960 mm - 1200 mm).
- * These wall rails can be easily cut to the required size. All cables also pass through the wall rail. (See Options below)
- * This 300 mm Combo Folding Arm with gas spring simply slides into the
- * wall rail to adjust to the desired height and fixed.
- * It has a safety height adjustment stop button, which allows the arm to remain in the chosen position.
- * The head of this arm complies with the standard for mounting screens: VESA MIS-D 75 mm and 100 mm.
- * Compatible with screens whose weight does not exceed 2 - 4,5 Kg.
- * Touch screen stability. * Screen tilt: 10°.
- * Screen rotation: 110° right, 110° left.
- * Arm rotation: 105° to the right, 105° to the left.
- * Height adjustment: 45° down, 45° up * Total length 821-916 mm
- * Foldable and removable keyboard and mouse holder: 500 x 200 mm
- * Compatible with multimedia terminals (TMM)
- * Color RAL 7024 (Graphite Grey) and White
- * All our medical arms are in conformity: CE, ROHS, Medical Grade, Regulations MDD 93/42 ECC.
- * Warranty: 5 years

Note: This arm can also be installed on one of our medical columns or trolleys.

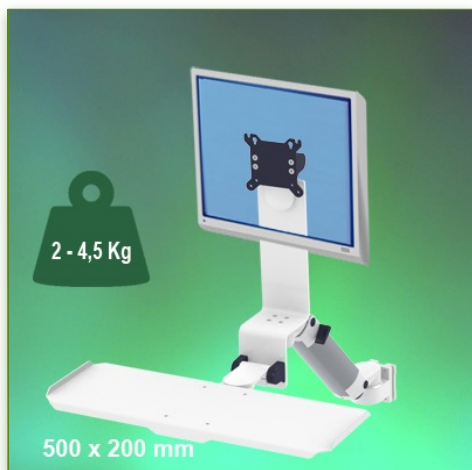

Display Compatibility: 26" Wide (Weight)
Supported Weight: 2- 4,5 Kg
VESA standard: 75 / 100 mm
Keyboard-Mouse holder: 500 x 200 mm

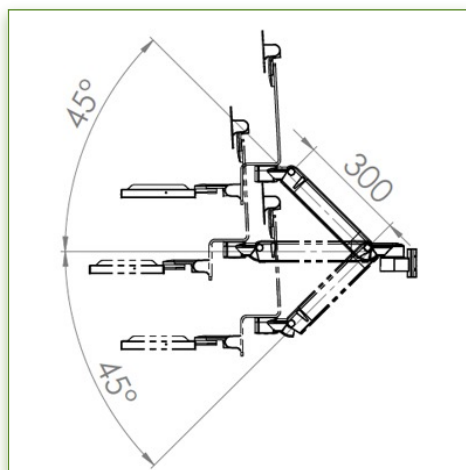
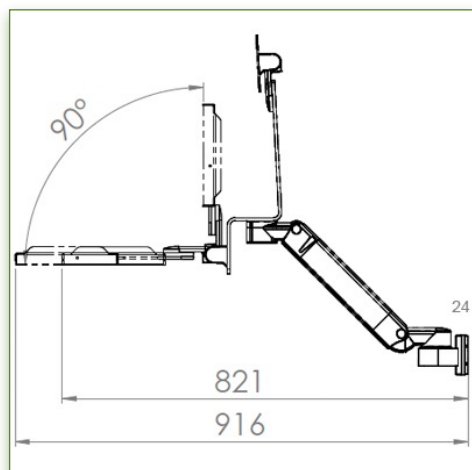
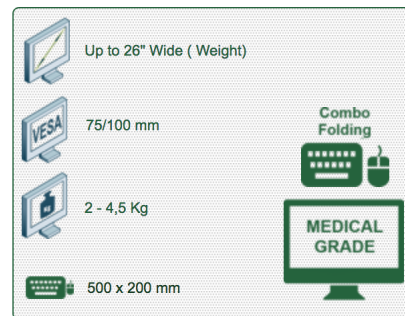

Do not hesitate to contact us if you have any questions about this product.

Warranty: 5 years

000.991.683-1-3

Graphite Grey and White

On Measure

= Depending on the elements

991.683-1-3

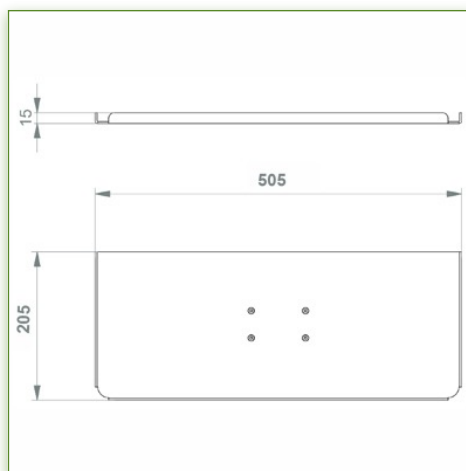
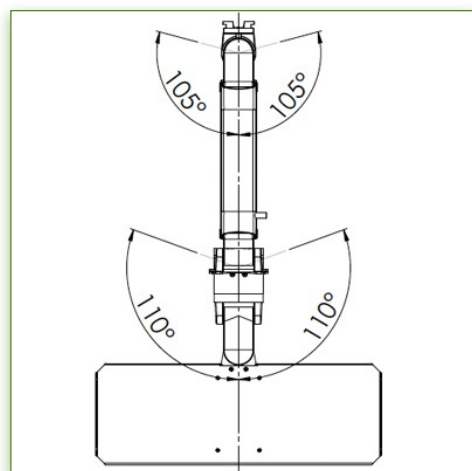

Anti-bacterial properties:

IT medical arms are now designed with Microban antibacterial protection, a revolutionary treatment that guarantees optimal hygiene. IT medical arms integrate Microban and other antibacterial agents into all medical products. It inhibits the growth of bacteria of all types. This is not a surface treatment. It is 100% in the totality of the product. It does not alter the physico-mechanical properties of the medical arm lift system. Simulations over 30 years show that 100% of the antibacterial properties are maintained. All medical articulated arms incorporate Microban. Microban is the world's leading provider of anti-bacterial solutions. It has been successfully applied for more than 35 years in a wide range of products used in the hospital, construction and food industries.

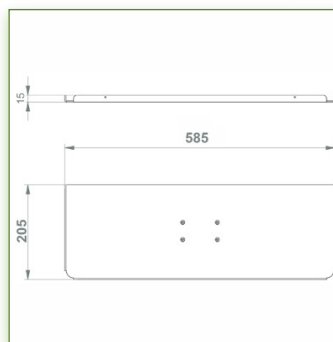
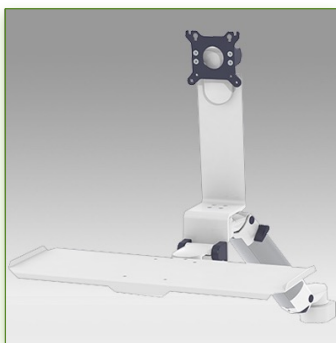

Display Compatibility: 26" Wide (Weight)
Supported Weight: 2- 4,5 Kg
VESA standard: 75 / 100 mm
Keyboard-Mouse holder: 580 x 200 mm

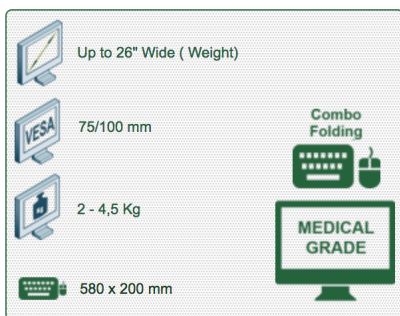

Do not hesitate to contact us if you have any questions about this product.

Warranty: 5 years

000.991.683-1-4

Graphite Grey and White

On Measure

= Depending on the elements

991.683-1-4

300 mm height-adjustable Medical Combo Folding Arm for monitor, keyboard and mouse, wall mounting on vertical sliding rail

This 300 mm Folding Combo Medical Arm with gas spring height adjustment allows the LCD screen to be perfectly fixed, oriented and adjusted and supports the keyboard and mouse. It is coated with an anti-microbial agent offering hygiene and cleaning down to the last detail. Its modern design has been specially designed for healthcare environments.

Technical specifications:

- * Integrated cable channel
- * Equipotential bonding
- * Optional Vertical Wall Slide Rail Mounting available in several lengths (480 mm - 720 mm - 960 mm - 1200 mm).
- * These wall rails can be easily cut to the required size. All cables also pass through the wall rail. (See Options below)
- * This 300 mm Combo Folding Arm with gas spring simply slides into the wall rail to adjust to the desired height and fixed.
- * It has a safety height adjustment stop button, which allows the arm to remain in the chosen position.
- * The head of this arm complies with the standard for mounting screens: VESA MIS-D 75 mm and 100 mm.
- * Compatible with screens whose weight does not exceed 2 - 4,5 Kg.
- * Touch screen stability. * Screen tilt: 10°.
- * Screen rotation: 110° right, 110° left.
- * Arm rotation: 105° to the right, 105° to the left.
- * Height adjustment: 45° down, 45° up * Total length 821-916 mm
- * Foldable and removable keyboard and mouse holder: 580 x 200 mm
- * Compatible with multimedia terminals (TMM)
- * Color RAL 7024 (Graphite Grey) and White
- * All our medical arms are in conformity: CE, ROHS, Medical Grade, Regulations MDD 93/42 ECC.
- * Warranty: 5 years

Note: This arm can also be installed on one of our medical columns or trolleys.

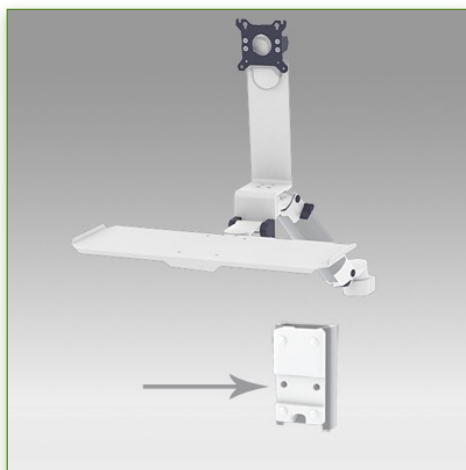

Display Compatibility: 26" Wide (Weight)
Supported Weight: 2- 4,5 Kg
VESA standard: 75 / 100 mm
Keyboard-Mouse holder: 580 x 200 mm

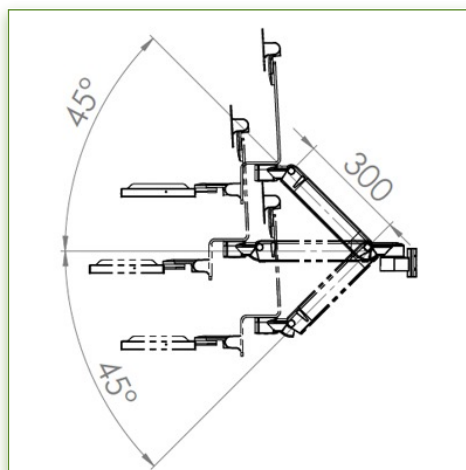
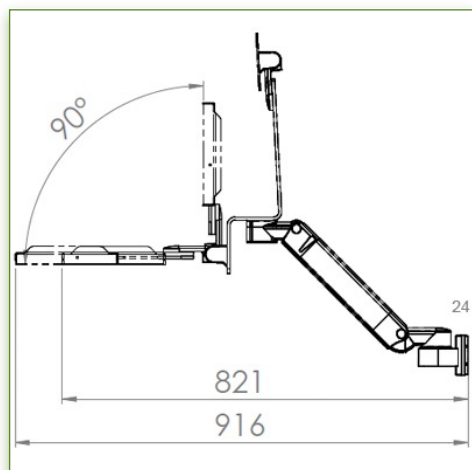
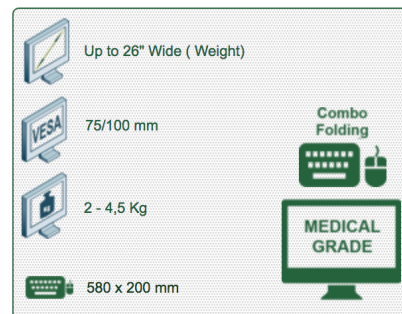

Do not hesitate to contact us if you have any questions about this product.

Warranty: 5 years

000.991.683-1-4

Graphite Grey and White

On Measure

= Depending on the elements

991.683-1-4

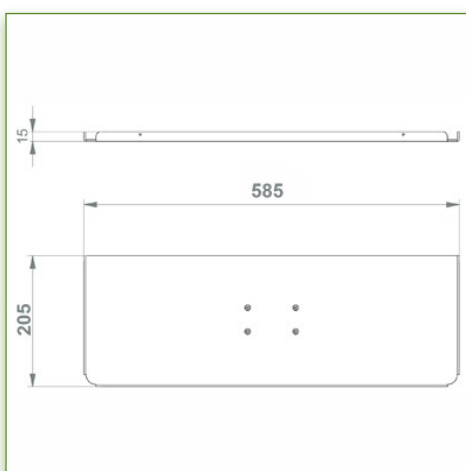
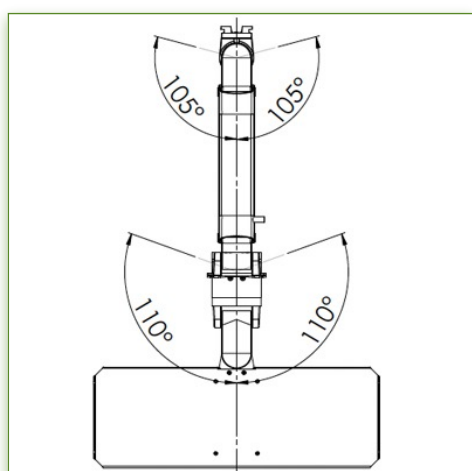

Anti-bacterial properties:

IT medical arms are now designed with Microban antibacterial protection, a revolutionary treatment that guarantees optimal hygiene. IT medical arms integrate Microban and other antibacterial agents into all medical products. It inhibits the growth of bacteria of all types. This is not a surface treatment.

It is 100% in the totality of the product. It does not alter the physico-mechanical properties of the medical arm lift system. Simulations over 30 years show that 100% of the antibacterial properties are maintained.

All medical articulated arms incorporate Microban. Microban is the world's leading provider of anti-bacterial solutions. It has been successfully applied for more than 35 years in a wide range of products used in the hospital, construction and food industries.

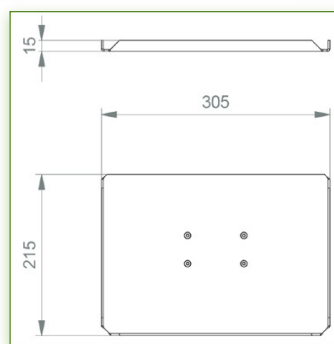
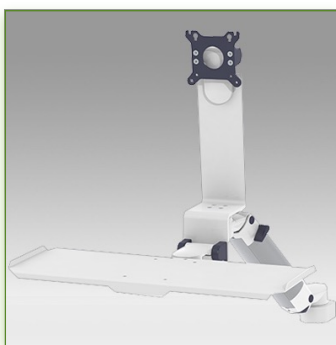

Display Compatibility: 26" Wide (Weight)
Supported Weight: 3- 7 Kg
VESA standard: 75 / 100 mm
Keyboard-Mouse holder: 300 x 210 mm

Jusque 26" Wide (Poids)

75/100 mm

3 - 7 Kg

300 x 210 mm

Combo Folding

MEDICAL GRADE

Do not hesitate to contact us if you have any questions about this product.

Warranty: 5 years

000.991.683-2-1

Graphite Grey and White

On Measure

= Depending on the elements

991.683-2-1

300 mm height-adjustable Medical Combo Folding Arm for monitor, keyboard and mouse, wall mounting on vertical sliding rail

This 300 mm Folding Combo Medical Arm with gas spring height adjustment allows the LCD screen to be perfectly fixed, oriented and adjusted and supports the keyboard and mouse. It is coated with an anti-microbial agent offering hygiene and cleaning down to the last detail. Its modern design has been specially designed for healthcare environments.

Technical specifications:

- * Integrated cable channel
- * Equipotential bonding
- * Optional Vertical Wall Slide Rail Mounting available in several lengths (480 mm - 720 mm - 960 mm - 1200 mm).
- * These wall rails can be easily cut to the required size. All cables also pass through the wall rail. (See Options below)
- * This 300 mm Combo Folding Arm with gas spring simply slides into the wall rail to adjust to the desired height and fixed.
- * It has a safety height adjustment stop button, which allows the arm to remain in the chosen position.
- * The head of this arm complies with the standard for mounting screens: VESA MIS-D 75 mm and 100 mm.
- * Compatible with screens whose weight does not exceed 3 - 7 Kg.
- * Touch screen stability.
- * Screen tilt: 10°. * Screen rotation: 110° right, 110° left.
- * Arm rotation: 105° to the right, 105° to the left.
- * Height adjustment: 45° down, 45° up * Total length 821-916 mm
- * Foldable and removable keyboard and mouse holder: 300 x 210 mm
- * Compatible with multimedia terminals (TMM)
- * Color RAL 7024 (Graphite Grey) and White
- * All our medical arms are in conformity: CE, ROHS, Medical Grade, Regulations MDD 93/42 ECC.
- * Warranty: 5 years

Note: This arm can also be installed on one of our medical columns or trolleys.

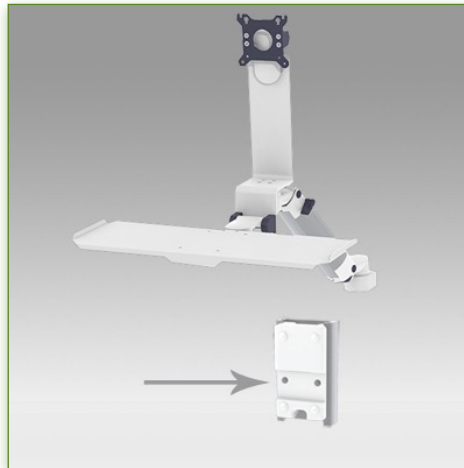

Display Compatibility: 26" Wide (Weight)
Supported Weight: 3- 7 Kg
VESA standard: 75 / 100 mm
Keyboard-Mouse holder: 300 x 210 mm

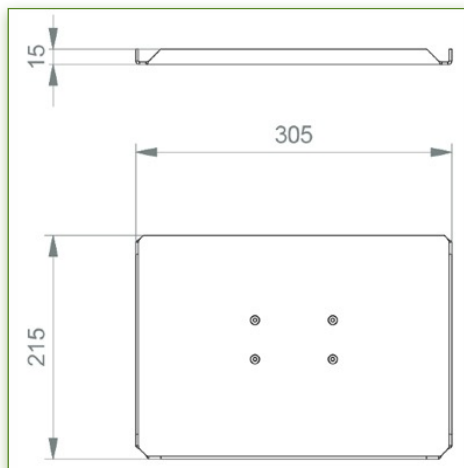
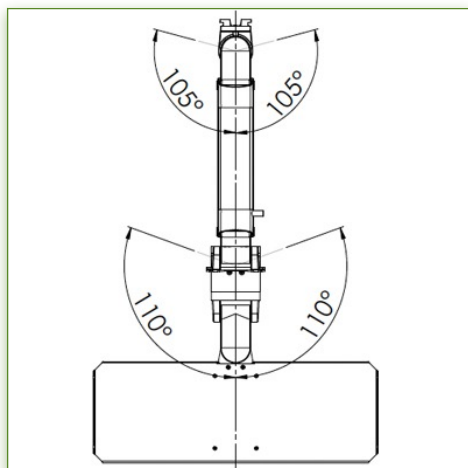
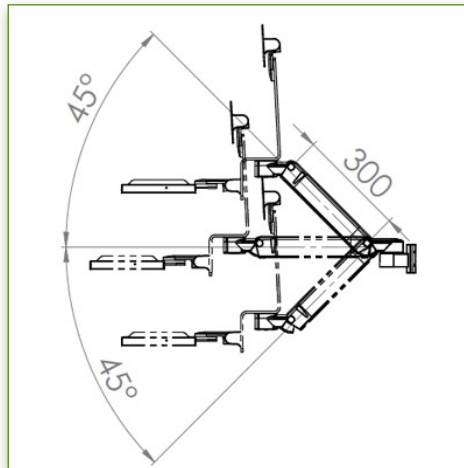
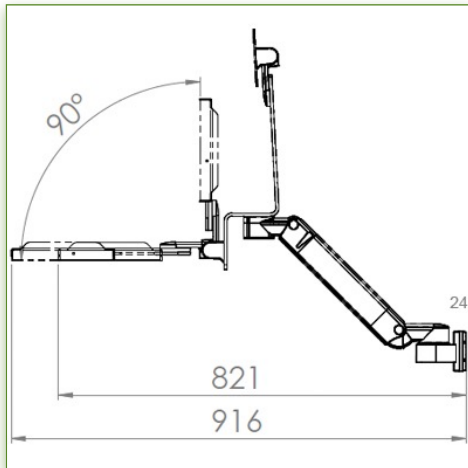
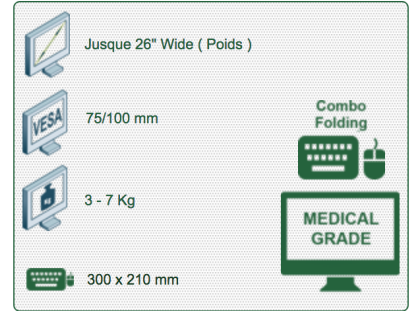

Do not hesitate to contact us if you have any questions about this product.

- Warranty: 5 years
- 000.991.683-2-1
- Graphite Grey and White
- On Measure
- = Depending on the elements
- 991.683-2-1

Anti-bacterial properties:

IT medical arms are now designed with Microban antibacterial protection, a revolutionary treatment that guarantees optimal hygiene. IT medical arms integrate Microban and other antibacterial agents into all medical products. It inhibits the growth of bacteria of all types. This is not a surface treatment. It is 100% in the totality of the product. It does not alter the physico-mechanical properties of the medical arm lift system. Simulations over 30 years show that 100% of the antibacterial properties are maintained. All medical articulated arms incorporate Microban. Microban is the world's leading provider of anti-bacterial solutions. It has been successfully applied for more than 35 years in a wide range of products used in the hospital, construction and food industries.

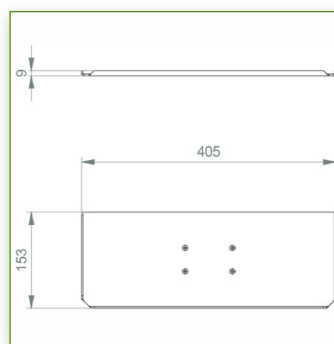

Display Compatibility: 26" Wide (Weight)
Supported Weight: 3- 7 Kg
VESA standard: 75 / 100 mm
Keyboard-Mouse holder: 400 x 150 mm

Up to 26" Wide (Weight)
75/100 mm
3 - 7 Kg
400 x 150 mm

Combo Folding
MEDICAL GRADE

Do not hesitate to contact us if you have any questions about this product.

Warranty: 5 years

000.991.683-2-2

Graphite Grey and White

On Measure

= Depending on the elements

991.683-2-2

300 mm height-adjustable Medical Combo Folding Arm for monitor, keyboard and mouse, wall mounting on vertical sliding rail

This 300 mm Folding Combo Medical Arm with gas spring height adjustment allows the LCD screen to be perfectly fixed, oriented and adjusted and supports the keyboard and mouse. It is coated with an anti-microbial agent offering hygiene and cleaning down to the last detail. Its modern design has been specially designed for healthcare environments.

Technical specifications:

- * Integrated cable channel
- * Equipotential bonding
- * Optional Vertical Wall Slide Rail Mounting available in several lengths (480 mm - 720 mm - 960 mm - 1200 mm).
- * These wall rails can be easily cut to the required size. All cables also pass through the wall rail. (See Options below)
- * This 300 mm Combo Folding Arm with gas spring simply slides into the wall rail to adjust to the desired height and fixed.
- * It has a safety height adjustment stop button, which allows the arm to remain in the chosen position.
- * The head of this arm complies with the standard for mounting screens: VESA MIS-D 75 mm and 100 mm.
- * Compatible with screens whose weight does not exceed 3 - 7 Kg.
- * Touch screen stability.
- * Screen tilt: 10°. * Screen rotation: 110° right, 110° left.
- * Arm rotation: 105° to the right, 105° to the left.
- * Height adjustment: 45° down, 45° up * Total length 821-916 mm
- * Foldable and removable keyboard and mouse holder: 400 x 150 mm
- * Compatible with multimedia terminals (TMM)
- * Color RAL 7024 (Graphite Grey) and White
- * All our medical arms are in conformity: CE, ROHS, Medical Grade, Regulations MDD 93/42 ECC.
- * Warranty: 5 years

Note: This arm can also be installed on one of our medical columns or trolleys.

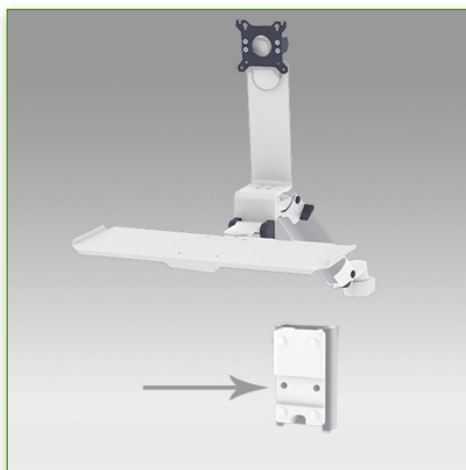

Display Compatibility: 26" Wide (Weight)
Supported Weight: 3- 7 Kg
VESA standard: 75 / 100 mm
Keyboard-Mouse holder: 400 x 150 mm

Up to 26" Wide (Weight)
75/100 mm
3 - 7 Kg
400 x 150 mm

Combo Folding

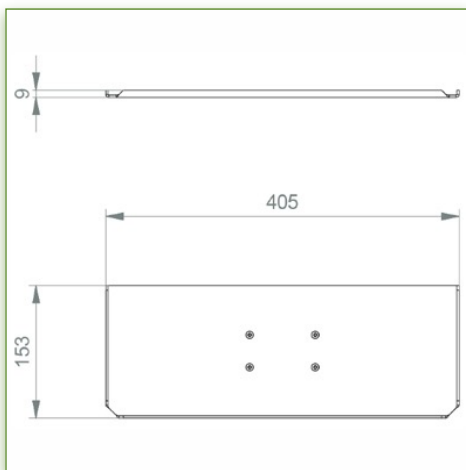
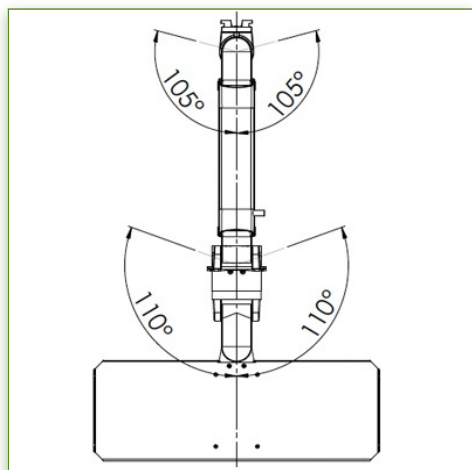
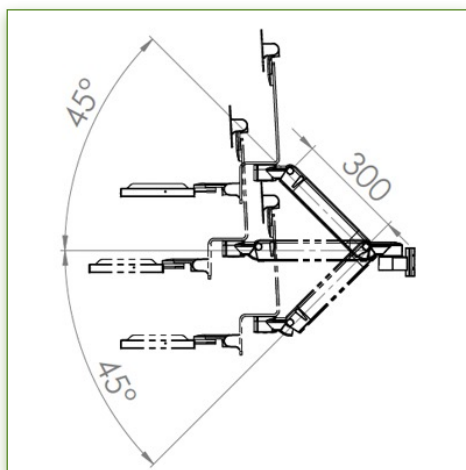
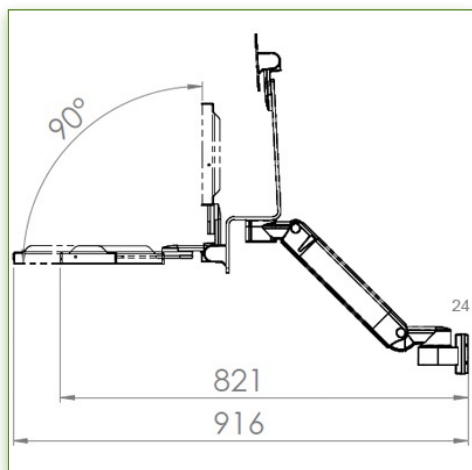

Do not hesitate to contact us if you have any questions about this product.

- Warranty: 5 years
- 000.991.683-2-2
- Graphite Grey and White
- On Measure
- = Depending on the elements
- 991.683-2-2

Anti-bacterial properties:

IT medical arms are now designed with Microban antibacterial protection, a revolutionary treatment that guarantees optimal hygiene. IT medical arms integrate Microban and other antibacterial agents into all medical products. It inhibits the growth of bacteria of all types. This is not a surface treatment. It is 100% in the totality of the product. It does not alter the physico-mechanical properties of the medical arm lift system. Simulations over 30 years show that 100% of the antibacterial properties are maintained. All medical articulated arms incorporate Microban. Microban is the world's leading provider of anti-bacterial solutions. It has been successfully applied for more than 35 years in a wide range of products used in the hospital, construction and food industries.

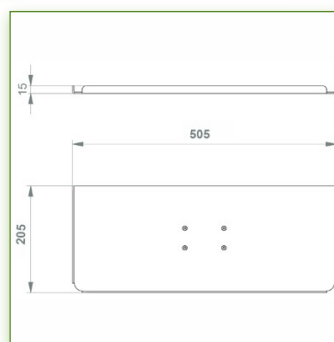
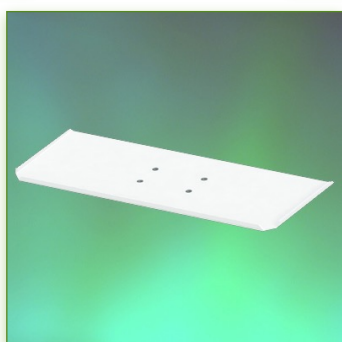

Display Compatibility: 26" Wide (Weight)
Supported Weight: 3- 7 Kg
VESA standard: 75 / 100 mm
Keyboard-Mouse holder: 500 x 200 mm

 Up to 26" Wide (Weight)
 75/100 mm
 3 - 7 Kg
 500 x 200 mm
MEDICAL GRADE
Combo Folding

Do not hesitate to contact us if you have any questions about this product.

Warranty: 5 years

000.991.683-2-3

Graphite Grey and White

On Measure

= Depending on the elements

991.683-2-3

300 mm height-adjustable Medical Combo Folding Arm for monitor, keyboard and mouse, wall mounting on vertical sliding rail

This 300 mm Folding Combo Medical Arm with gas spring height adjustment allows the LCD screen to be perfectly fixed, oriented and adjusted and supports the keyboard and mouse. It is coated with an anti-microbial agent offering hygiene and cleaning down to the last detail. Its modern design has been specially designed for healthcare environments.

Technical specifications:

- * Integrated cable channel
- * Equipotential bonding
- * Optional Vertical Wall Slide Rail Mounting available in several lengths (480 mm - 720 mm - 960 mm - 1200 mm).
- * These wall rails can be easily cut to the required size. All cables also pass through the wall rail. (See Options below)
- * This 300 mm Combo Folding Arm with gas spring simply slides into the wall rail to adjust to the desired height and fixed.
- * It has a safety height adjustment stop button, which allows the arm to remain in the chosen position.
- * The head of this arm complies with the standard for mounting screens: VESA MIS-D 75 mm and 100 mm.
- * Compatible with screens whose weight does not exceed 3 - 7 Kg.
- * Touch screen stability.
- * Screen tilt: 10°. * Screen rotation: 110° right, 110° left.
- * Arm rotation: 105° to the right, 105° to the left.
- * Height adjustment: 45° down, 45° up * Total length 821-916 mm
- * Foldable and removable keyboard and mouse holder: 500 x 200 mm
- * Compatible with multimedia terminals (TMM)
- * Color RAL 7024 (Graphite Grey) and White
- * All our medical arms are in conformity: CE, ROHS, Medical Grade, Regulations MDD 93/42 ECC.
- * Warranty: 5 years

Note: This arm can also be installed on one of our medical columns or trolleys.

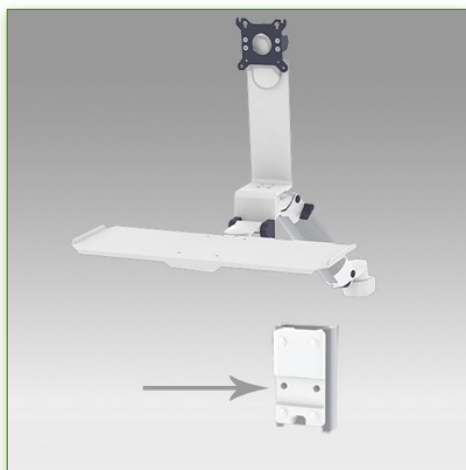

Display Compatibility: 26" Wide (Weight)
Supported Weight: 3- 7 Kg
VESA standard: 75 / 100 mm
Keyboard-Mouse holder: 500 x 200 mm

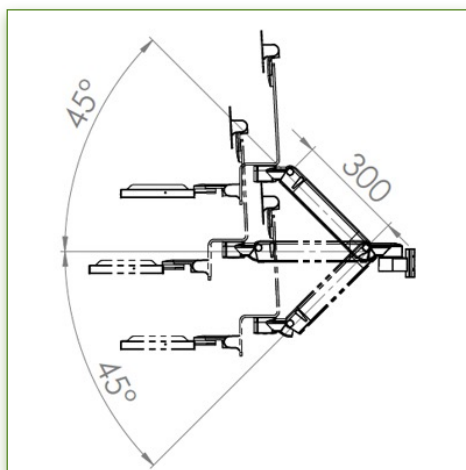
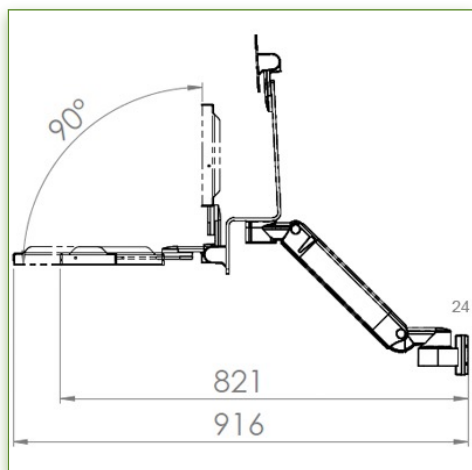
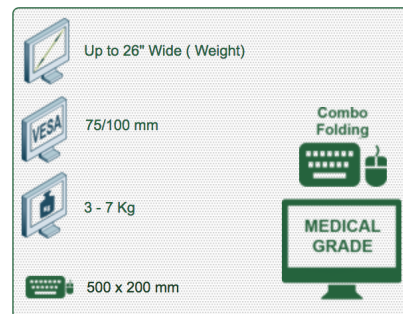

Do not hesitate to contact us if you have any questions about this product.

- Warranty: 5 years
- 000.991.683-2-3
- Graphite Grey and White
- On Measure
- = Depending on the elements
- 991.683-2-3

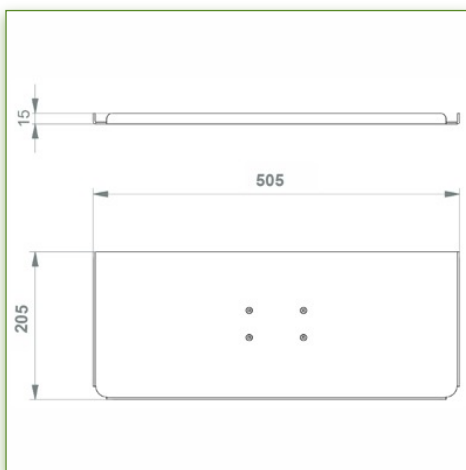
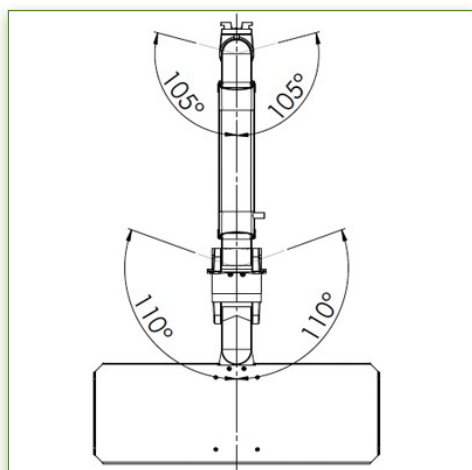

Anti-bacterial properties:

IT medical arms are now designed with Microban antibacterial protection, a revolutionary treatment that guarantees optimal hygiene. IT medical arms integrate Microban and other antibacterial agents into all medical products. It inhibits the growth of bacteria of all types. This is not a surface treatment. It is 100% in the totality of the product. It does not alter the physico-mechanical properties of the medical arm lift system. Simulations over 30 years show that 100% of the antibacterial properties are maintained. All medical articulated arms incorporate Microban. Microban is the world's leading provider of anti-bacterial solutions. It has been successfully applied for more than 35 years in a wide range of products used in the hospital, construction and food industries.

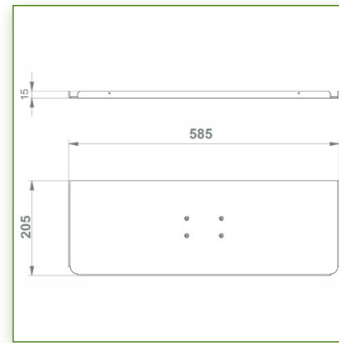
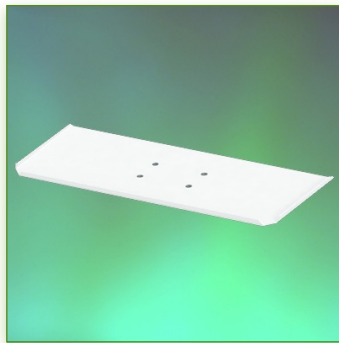
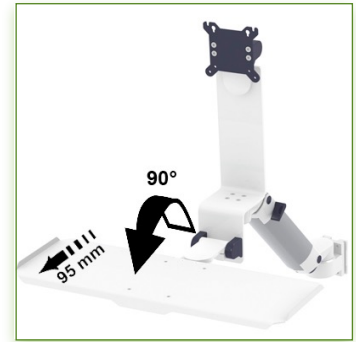
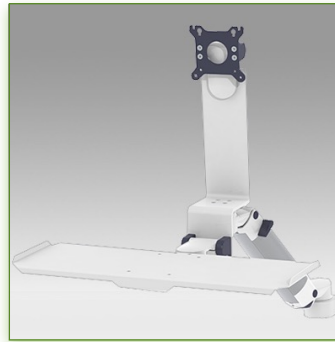

Display Compatibility: 26" Wide (Weight)
Supported Weight: 3- 7 Kg
VESA standard: 75 / 100 mm
Keyboard-Mouse holder: 580 x 200 mm

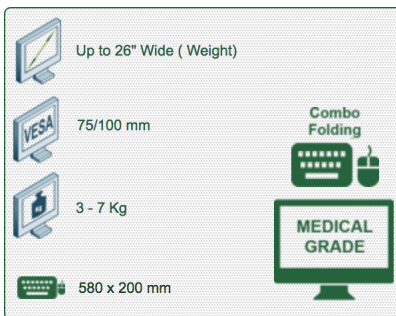

300 mm height-adjustable Medical Combo Folding Arm for monitor, keyboard and mouse, wall mounting on vertical sliding rail

This 300 mm Folding Combo Medical Arm with gas spring height adjustment allows the LCD screen to be perfectly fixed, oriented and adjusted and supports the keyboard and mouse. It is coated with an anti-microbial agent offering hygiene and cleaning down to the last detail. Its modern design has been specially designed for healthcare environments.

Technical specifications:

- * Integrated cable channel
- * Equipotential bonding
- * Optional Vertical Wall Slide Rail Mounting available in several lengths (480 mm - 720 mm - 960 mm - 1200 mm).
- * These wall rails can be easily cut to the required size. All cables also pass through the wall rail. (See Options below)
- * This 300 mm Combo Folding Arm with gas spring simply slides into the wall rail to adjust to the desired height and fixed.
- * It has a safety height adjustment stop button, which allows the arm to remain in the chosen position.
- * The head of this arm complies with the standard for mounting screens: VESA MIS-D 75 mm and 100 mm.
- * Compatible with screens whose weight does not exceed 3 - 7 Kg.
- * Touch screen stability.
- * Screen tilt: 10°. * Screen rotation: 110° right, 110° left.
- * Arm rotation: 105° to the right, 105° to the left.
- * Height adjustment: 45° down, 45° up * Total length 821-916 mm
- * Foldable and removable keyboard and mouse holder: 580 x 200 mm
- * Compatible with multimedia terminals (TMM)
- * Color RAL 7024 (Graphite Grey) and White
- * All our medical arms are in conformity: CE, ROHS, Medical Grade, Regulations MDD 93/42 ECC.
- * Warranty: 5 years

Note: This arm can also be installed on one of our medical columns or trolleys.

Do not hesitate to contact us if you have any questions about this product.

Warranty: 5 years

000.991.683-2-4

Graphite Grey and White

On Measure

= Depending on the elements

991.683-2-4



Display Compatibility: 26" Wide (Weight)
Supported Weight: 3- 7 Kg
VESA standard: 75 / 100 mm
Keyboard-Mouse holder: 580 x 200 mm

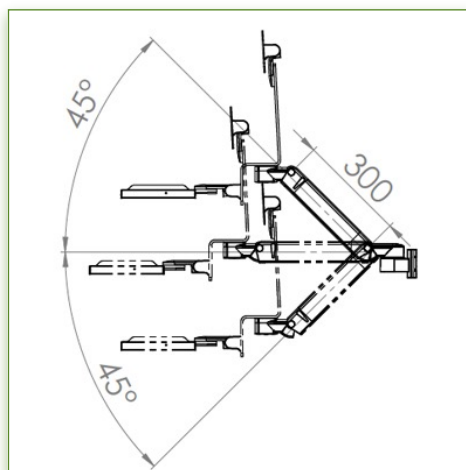
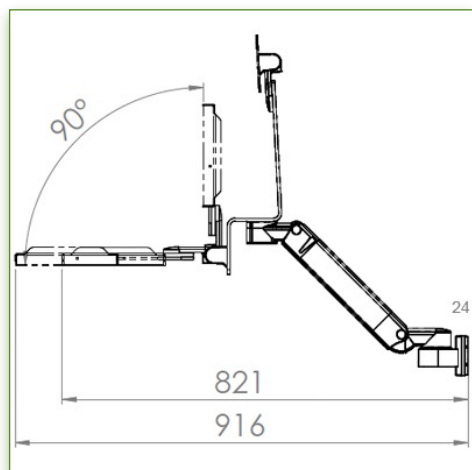
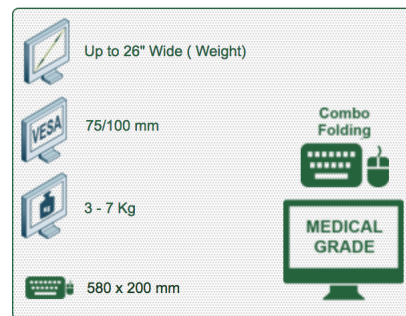

Do not hesitate to contact us if you have any questions about this product.

- Warranty: 5 years
- 000.991.683-2-4
- Graphite Grey and White
- On Measure
- = Depending on the elements
- 991.683-2-4

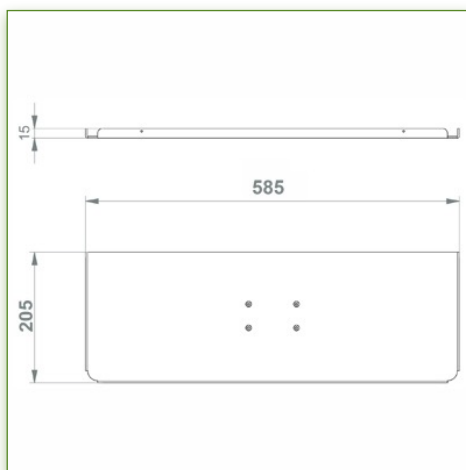
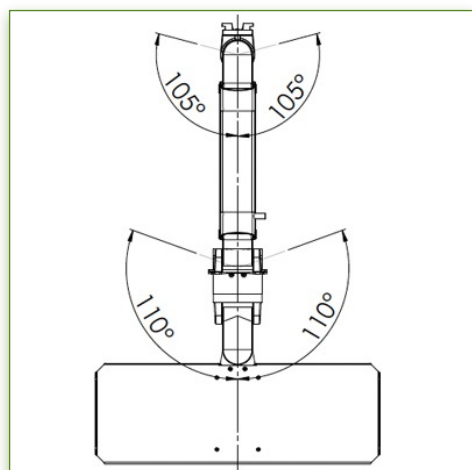

Anti-bacterial properties:

IT medical arms are now designed with Microban antibacterial protection, a revolutionary treatment that guarantees optimal hygiene. IT medical arms integrate Microban and other antibacterial agents into all medical products. It inhibits the growth of bacteria of all types. This is not a surface treatment. It is 100% in the totality of the product. It does not alter the physico-mechanical properties of the medical arm lift system. Simulations over 30 years show that 100% of the antibacterial properties are maintained. All medical articulated arms incorporate Microban. Microban is the world's leading provider of anti-bacterial solutions. It has been successfully applied for more than 35 years in a wide range of products used in the hospital, construction and food industries.

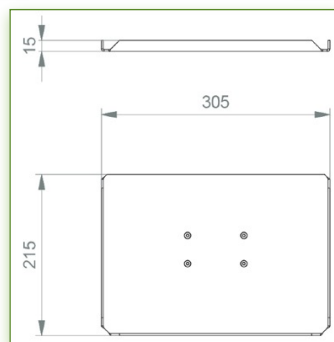
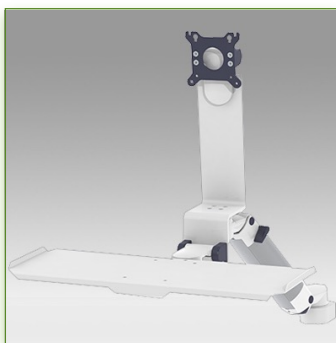

Display Compatibility: 26" Wide (Weight)
Supported Weight: 4- 9,5 Kg
VESA standard: 75 / 100 mm
Keyboard-Mouse holder: 300 x 210 mm

Up to 26" Wide (Weight)
75/100 mm
4 - 9,5 Kg
300 x 210 mm

Combo Folding
MEDICAL GRADE

Do not hesitate to contact us if you have any questions about this product.

Warranty: 5 years

000.991.683-3-1

Graphite Grey and White

On Measure

= Depending on the elements

991.683-3-1

300 mm height-adjustable Medical Combo Folding Arm for monitor, keyboard and mouse, wall mounting on vertical sliding rail

This 300 mm Folding Combo Medical Arm with gas spring height adjustment allows the LCD screen to be perfectly fixed, oriented and adjusted and supports the keyboard and mouse. It is coated with an anti-microbial agent offering hygiene and cleaning down to the last detail. Its modern design has been specially designed for healthcare environments.

Technical specifications:

- * Integrated cable channel
- * Equipotential bonding
- * Optional Vertical Wall Slide Rail Mounting available in several lengths (480 mm - 720 mm - 960 mm - 1200 mm).
- * These wall rails can be easily cut to the required size. All cables also pass through the wall rail. (See Options below)
- * This 300 mm Combo Folding Arm with gas spring simply slides into the wall rail to adjust to the desired height and fixed.
- * It has a safety height adjustment stop button, which allows the arm to remain in the chosen position.
- * The head of this arm complies with the standard for mounting screens: VESA MIS-D 75 mm and 100 mm.
- * Compatible with screens whose weight does not exceed 4 - 9,5 Kg.
- * Touch screen stability.
- * Screen tilt: 10°. * Screen rotation: 110° right, 110° left.
- * Arm rotation: 105° to the right, 105° to the left.
- * Height adjustment: 45° down, 45° up * Total length 821-916 mm
- * Foldable and removable keyboard and mouse holder: 300 x 210 mm
- * Compatible with multimedia terminals (TMM)
- * Color RAL 7024 (Graphite Grey) and White
- * All our medical arms are in conformity: CE, ROHS, Medical Grade, Regulations MDD 93/42 ECC.
- * Warranty: 5 years

Note: This arm can also be installed on one of our medical columns or trolleys.

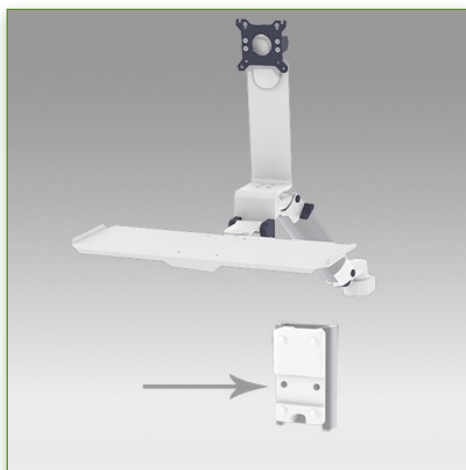

Display Compatibility: 26" Wide (Weight)
Supported Weight: 4- 9,5 Kg
VESA standard: 75 / 100 mm
Keyboard-Mouse holder: 300 x 210 mm

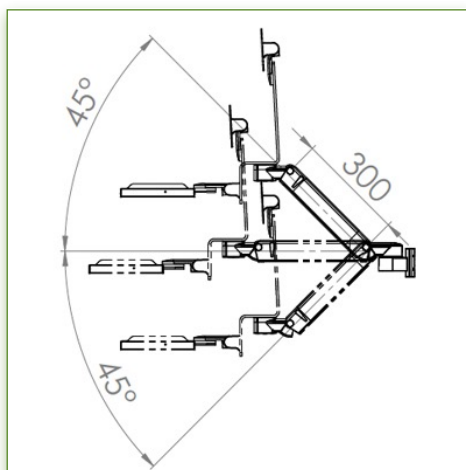
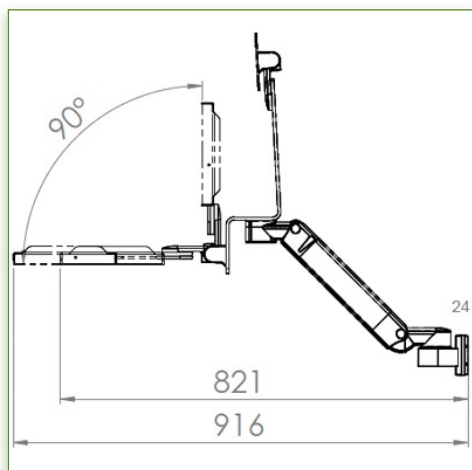
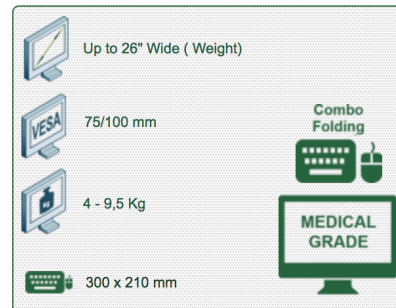

Do not hesitate to contact us if you have any questions about this product.

Warranty: 5 years

000.991.683-3-1

Graphite Grey and White

On Measure

= Depending on the elements

991.683-3-1

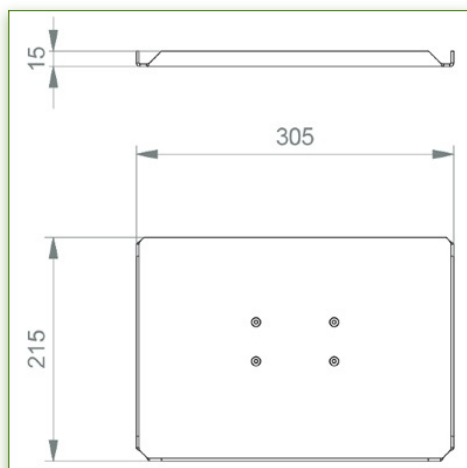
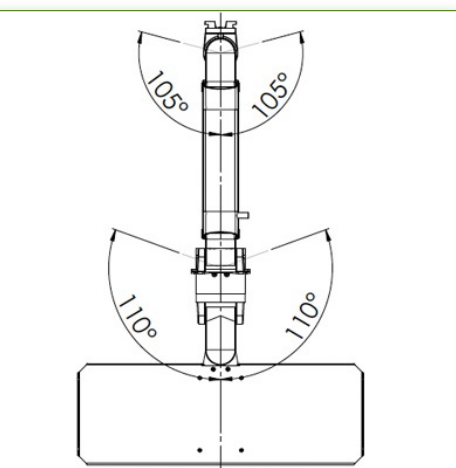

Anti-bacterial properties:

IT medical arms are now designed with Microban antibacterial protection, a revolutionary treatment that guarantees optimal hygiene. IT medical arms integrate Microban and other antibacterial agents into all medical products. It inhibits the growth of bacteria of all types. This is not a surface treatment. It is 100% in the totality of the product. It does not alter the physico-mechanical properties of the medical arm lift system. Simulations over 30 years show that 100% of the antibacterial properties are maintained. All medical articulated arms incorporate Microban. Microban is the world's leading provider of anti-bacterial solutions. It has been successfully applied for more than 35 years in a wide range of products used in the hospital, construction and food industries.

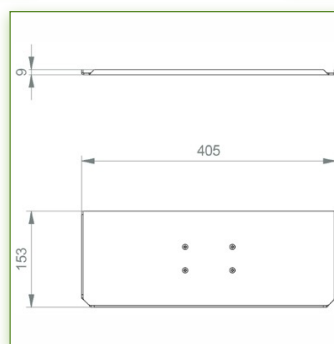
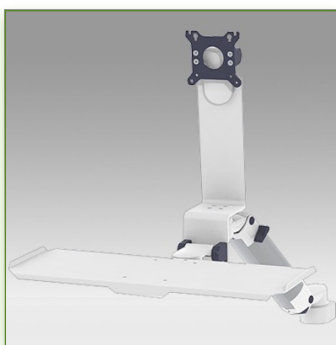

Display Compatibility: 26" Wide (Weight)
Supported Weight: 4- 9,5 Kg
VESA standard: 75 / 100 mm
Keyboard-Mouse holder: 400 x 150 mm

 Up to 26" Wide (Weight)
 75/100 mm
 4 - 9,5 Kg
 400 x 150 mm
 MEDICAL GRADE
 Combo Folding

Do not hesitate to contact us if you have any questions about this product.

Warranty: 5 years

000.991.683-3-2

Graphite Grey and White

On Measure

= Depending on the elements

991.683-3-2

300 mm height-adjustable Medical Combo Folding Arm for monitor, keyboard and mouse, wall mounting on vertical sliding rail

This 300 mm Folding Combo Medical Arm with gas spring height adjustment allows the LCD screen to be perfectly fixed, oriented and adjusted and supports the keyboard and mouse. It is coated with an anti-microbial agent offering hygiene and cleaning down to the last detail. Its modern design has been specially designed for healthcare environments.

Technical specifications:

- * Integrated cable channel
- * Equipotential bonding
- * Optional Vertical Wall Slide Rail Mounting available in several lengths (480 mm - 720 mm - 960 mm - 1200 mm).
- * These wall rails can be easily cut to the required size. All cables also pass through the wall rail. (See Options below)
- * This 300 mm Combo Folding Arm with gas spring simply slides into the wall rail to adjust to the desired height and fixed.
- * It has a safety height adjustment stop button, which allows the arm to remain in the chosen position.
- * The head of this arm complies with the standard for mounting screens: VESA MIS-D 75 mm and 100 mm.
- * Compatible with screens whose weight does not exceed 4 - 9,5 Kg.
- * Touch screen stability.
- * Screen tilt: 10°. * Screen rotation: 110° right, 110° left.
- * Arm rotation: 105° to the right, 105° to the left.
- * Height adjustment: 45° down, 45° up * Total length 821-916 mm
- * Foldable and removable keyboard and mouse holder: 400 x 150 mm
- * Compatible with multimedia terminals (TMM)
- * Color RAL 7024 (Graphite Grey) and White
- * All our medical arms are in conformity: CE, ROHS, Medical Grade, Regulations MDD 93/42 ECC.
- * Warranty: 5 years

Note: This arm can also be installed on one of our medical columns or trolleys.

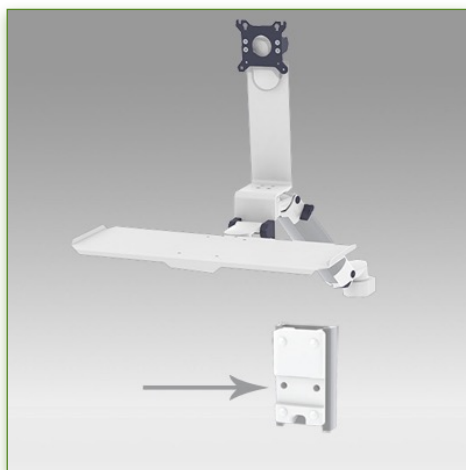

Display Compatibility: 26" Wide (Weight)
Supported Weight: 4- 9,5 Kg
VESA standard: 75 / 100 mm
Keyboard-Mouse holder: 400 x 150 mm

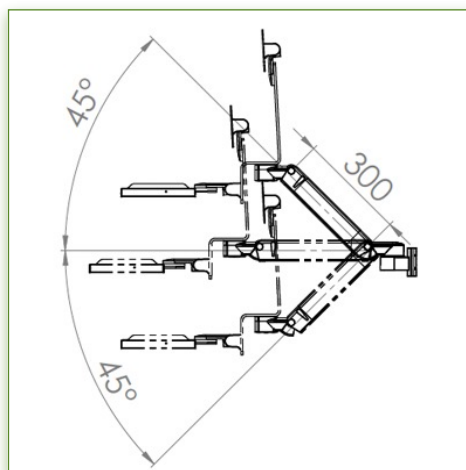
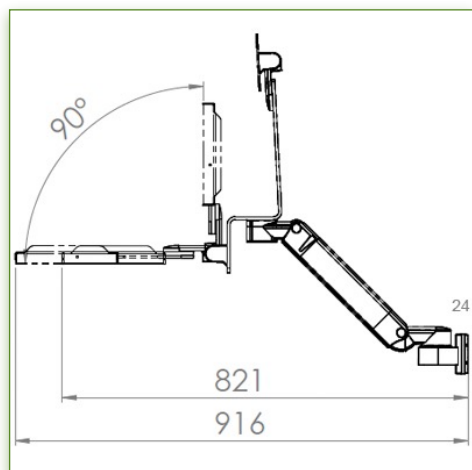
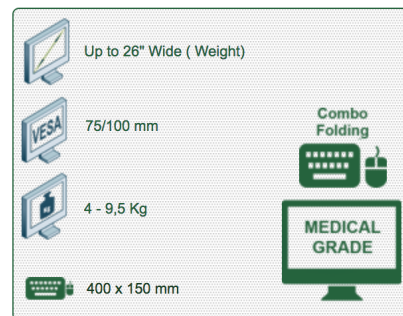

Do not hesitate to contact us if you have any questions about this product.

Warranty: 5 years

000.991.683-3-2

Graphite Grey and White

On Measure

= Depending on the elements

991.683-3-2

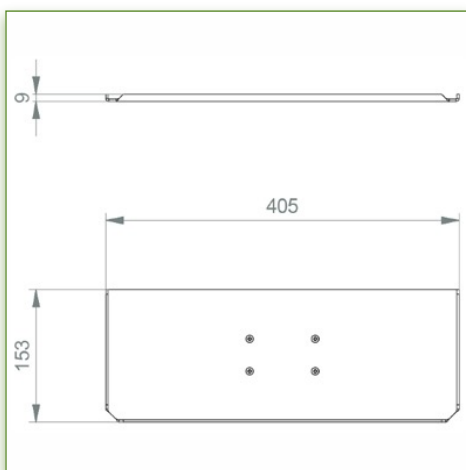
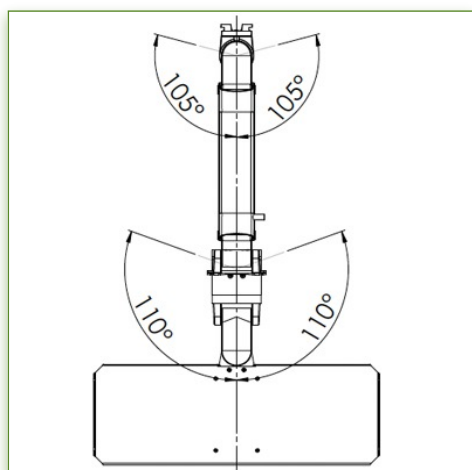

Anti-bacterial properties:

IT medical arms are now designed with Microban antibacterial protection, a revolutionary treatment that guarantees optimal hygiene. IT medical arms integrate Microban and other antibacterial agents into all medical products. It inhibits the growth of bacteria of all types. This is not a surface treatment. It is 100% in the totality of the product. It does not alter the physico-mechanical properties of the medical arm lift system. Simulations over 30 years show that 100% of the antibacterial properties are maintained. All medical articulated arms incorporate Microban. Microban is the world's leading provider of anti-bacterial solutions. It has been successfully applied for more than 35 years in a wide range of products used in the hospital, construction and food industries.

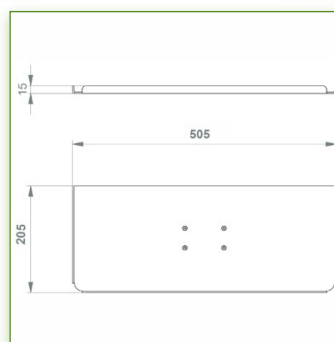
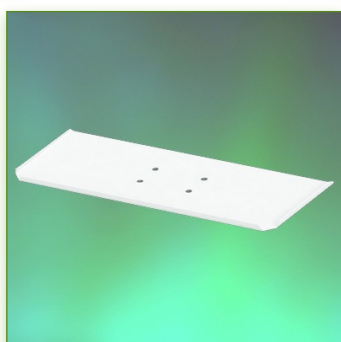
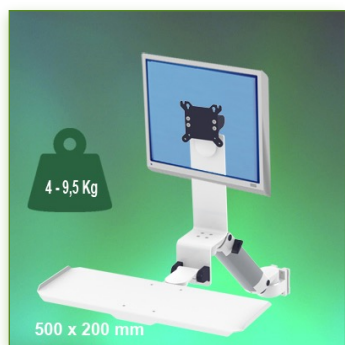

Display Compatibility: 26" Wide (Weight)
Supported Weight: 4- 9,5 Kg
VESA standard: 75 / 100 mm
Keyboard-Mouse holder: 500 x 200 mm

Up to 26" Wide (Weight)
75/100 mm
4 - 9,5 Kg
500 x 200 mm

Combo Folding
MEDICAL GRADE

Do not hesitate to contact us if you have any questions about this product.

Warranty: 5 years

000.991.683-3-3

Graphite Grey and White

On Measure

= Depending on the elements

991.683-3-3

300 mm height-adjustable Medical Combo Folding Arm for monitor, keyboard and mouse, wall mounting on vertical sliding rail

This 300 mm Folding Combo Medical Arm with gas spring height adjustment allows the LCD screen to be perfectly fixed, oriented and adjusted and supports the keyboard and mouse. It is coated with an anti-microbial agent offering hygiene and cleaning down to the last detail. Its modern design has been specially designed for healthcare environments.

Technical specifications:

- * Integrated cable channel
- * Equipotential bonding
- * Optional Vertical Wall Slide Rail Mounting available in several lengths (480 mm - 720 mm - 960 mm - 1200 mm).
- * These wall rails can be easily cut to the required size. All cables also pass through the wall rail. (See Options below)
- * This 300 mm Combo Folding Arm with gas spring simply slides into the wall rail to adjust to the desired height and fixed.
- * It has a safety height adjustment stop button, which allows the arm to remain in the chosen position.
- * The head of this arm complies with the standard for mounting screens: VESA MIS-D 75 mm and 100 mm.
- * Compatible with screens whose weight does not exceed 4 - 9,5 Kg.
- * Touch screen stability.
- * Screen tilt: 10°. * Screen rotation: 110° right, 110° left.
- * Arm rotation: 105° to the right, 105° to the left.
- * Height adjustment: 45° down, 45° up * Total length 821-916 mm
- * Foldable and removable keyboard and mouse holder: 500 x 200 mm
- * Compatible with multimedia terminals (TMM)
- * Color RAL 7024 (Graphite Grey) and White
- * All our medical arms are in conformity: CE, ROHS, Medical Grade, Regulations MDD 93/42 ECC.
- * Warranty: 5 years

Note: This arm can also be installed on one of our medical columns or trolleys.

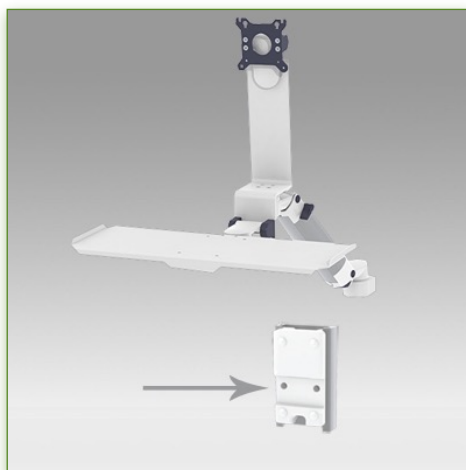
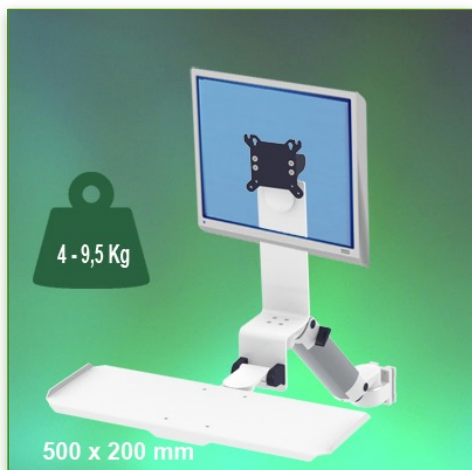

Display Compatibility: 26" Wide (Weight)
Supported Weight: 4- 9,5 Kg
VESA standard: 75 / 100 mm
Keyboard-Mouse holder: 500 x 200 mm

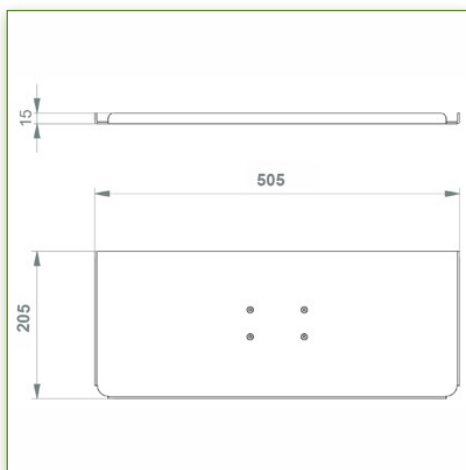
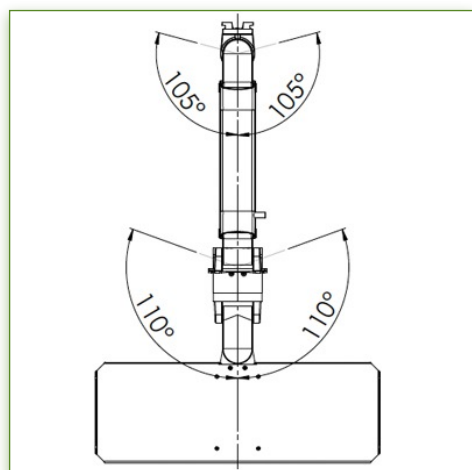
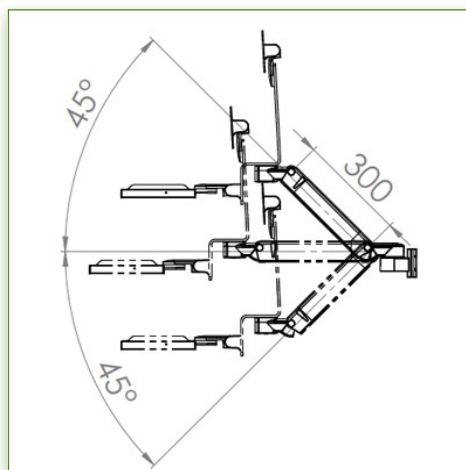
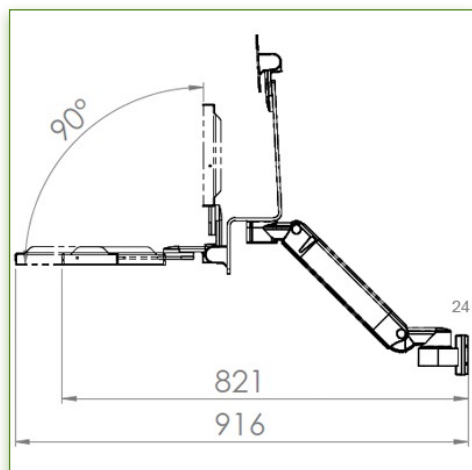
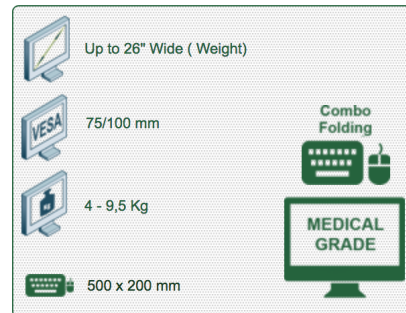

Do not hesitate to contact us if you have any questions about this product.

Warranty: 5 years

000.991.683-3-3

Graphite Grey and White

On Measure

= Depending on the elements

991.683-3-3

Anti-bacterial properties:

IT medical arms are now designed with Microban antibacterial protection, a revolutionary treatment that guarantees optimal hygiene. IT medical arms integrate Microban and other antibacterial agents into all medical products. It inhibits the growth of bacteria of all types. This is not a surface treatment. It is 100% in the totality of the product. It does not alter the physico-mechanical properties of the medical arm lift system. Simulations over 30 years show that 100% of the antibacterial properties are maintained. All medical articulated arms incorporate Microban. Microban is the world's leading provider of anti-bacterial solutions. It has been successfully applied for more than 35 years in a wide range of products used in the hospital, construction and food industries.

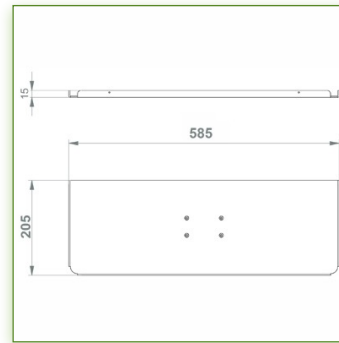
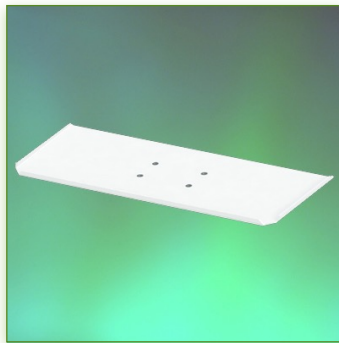
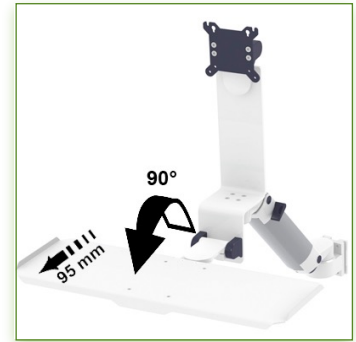
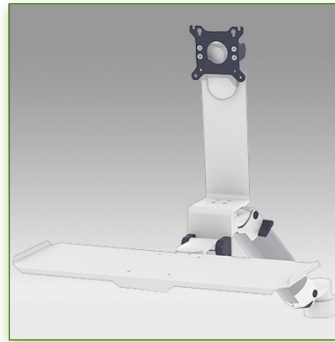

Display Compatibility: 26" Wide (Weight)
Supported Weight: 4- 9,5 Kg
VESA standard: 75 / 100 mm
Keyboard-Mouse holder: 580 x 200 mm

 Up to 26" Wide (Weight)
 75/100 mm
 4 - 9,5 Kg
 580 x 200 mm
 MEDICAL GRADE
 Combo Folding

Do not hesitate to contact us if you have any questions about this product.

Warranty: 5 years

000.991.683-3-4

Graphite Grey and White

On Measure

= Depending on the elements

991.683-3-4

300 mm height-adjustable Medical Combo Folding Arm for monitor, keyboard and mouse, wall mounting on vertical sliding rail

This 300 mm Folding Combo Medical Arm with gas spring height adjustment allows the LCD screen to be perfectly fixed, oriented and adjusted and supports the keyboard and mouse. It is coated with an anti-microbial agent offering hygiene and cleaning down to the last detail. Its modern design has been specially designed for healthcare environments.

Technical specifications:

- * Integrated cable channel
- * Equipotential bonding
- * Optional Vertical Wall Slide Rail Mounting available in several lengths (480 mm - 720 mm - 960 mm - 1200 mm).
- * These wall rails can be easily cut to the required size. All cables also pass through the wall rail. (See Options below)
- * This 300 mm Combo Folding Arm with gas spring simply slides into the wall rail to adjust to the desired height and fixed.
- * It has a safety height adjustment stop button, which allows the arm to remain in the chosen position.
- * The head of this arm complies with the standard for mounting screens: VESA MIS-D 75 mm and 100 mm.
- * Compatible with screens whose weight does not exceed 4 - 9,5 Kg.
- * Touch screen stability.
- * Screen tilt: 10°. * Screen rotation: 110° right, 110° left.
- * Arm rotation: 105° to the right, 105° to the left.
- * Height adjustment: 45° down, 45° up * Total length 821-916 mm
- * Foldable and removable keyboard and mouse holder: 580 x 200 mm
- * Compatible with multimedia terminals (TMM)
- * Color RAL 7024 (Graphite Grey) and White
- * All our medical arms are in conformity: CE, ROHS, Medical Grade, Regulations MDD 93/42 ECC.
- * Warranty: 5 years

Note: This arm can also be installed on one of our medical columns or trolleys.



Display Compatibility: 26" Wide (Weight)
Supported Weight: 4- 9,5 Kg
VESA standard: 75 / 100 mm
Keyboard-Mouse holder: 580 x 200 mm

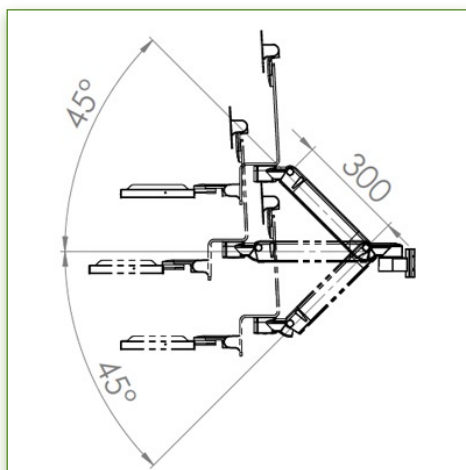
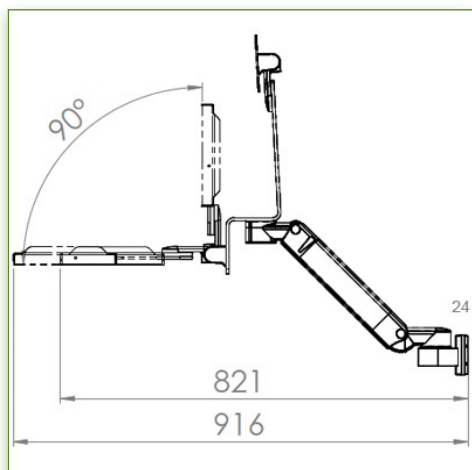
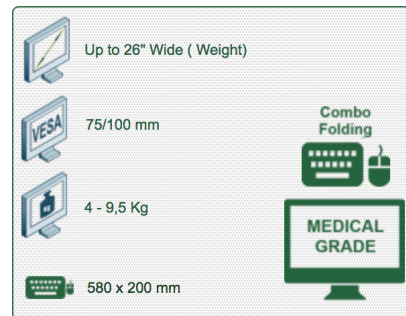

Do not hesitate to contact us if you have any questions about this product.

- Warranty: 5 years
- 000.991.683-3-4
- Graphite Grey and White
- On Measure
- = Depending on the elements
- 991.683-3-4

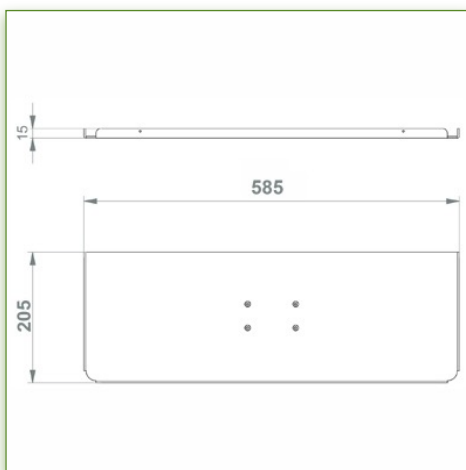
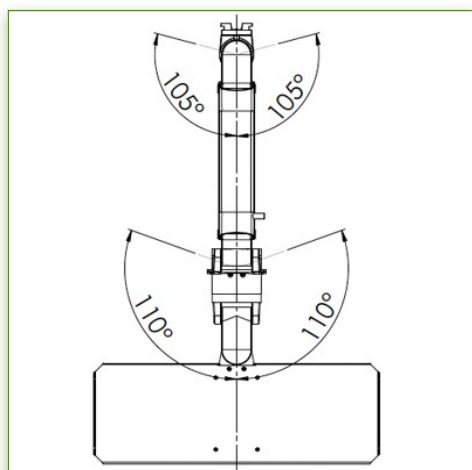

Anti-bacterial properties:

IT medical arms are now designed with Microban antibacterial protection, a revolutionary treatment that guarantees optimal hygiene. IT medical arms integrate Microban and other antibacterial agents into all medical products. It inhibits the growth of bacteria of all types. This is not a surface treatment. It is 100% in the totality of the product. It does not alter the physico-mechanical properties of the medical arm lift system. Simulations over 30 years show that 100% of the antibacterial properties are maintained. All medical articulated arms incorporate Microban. Microban is the world's leading provider of anti-bacterial solutions. It has been successfully applied for more than 35 years in a wide range of products used in the hospital, construction and food industries.

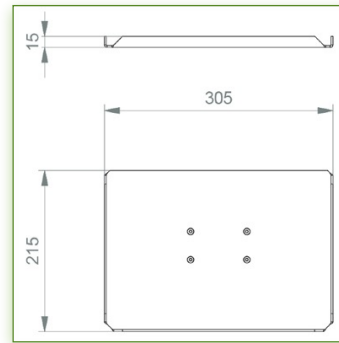
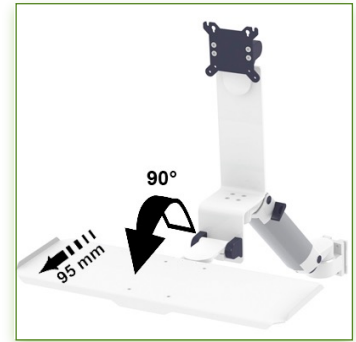
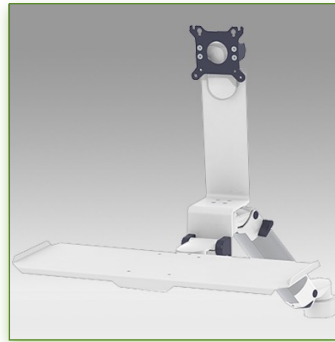

Display Compatibility: 26" Wide (Weight)
Supported Weight: 10- 11,5 Kg
VESA standard: 75 / 100 mm
Keyboard-Mouse holder: 300 x 210 mm

Up to 26" Wide (Weight)

75/100 mm

10 - 11,5 Kg

300 x 210 mm

Combo Folding

MEDICAL GRADE

Do not hesitate to contact us if you have any questions about this product.

Warranty: 5 years

000.991.683-4-1

Graphite Grey and White

On Measure

= Depending on the elements

991.683-4-1

300 mm height-adjustable Medical Combo Folding Arm for monitor, keyboard and mouse, wall mounting on vertical sliding rail

This 300 mm Folding Combo Medical Arm with gas spring height adjustment allows the LCD screen to be perfectly fixed, oriented and adjusted and supports the keyboard and mouse. It is coated with an anti-microbial agent offering hygiene and cleaning down to the last detail. Its modern design has been specially designed for healthcare environments.

Technical specifications:

- * Integrated cable channel
- * Equipotential bonding
- * Optional Vertical Wall Slide Rail Mounting available in several lengths (480 mm - 720 mm - 960 mm - 1200 mm).
- * These wall rails can be easily cut to the required size. All cables also pass through the wall rail. (See Options below)
- * This 300 mm Combo Folding Arm with gas spring simply slides into the wall rail to adjust to the desired height and fixed.
- * It has a safety height adjustment stop button, which allows the arm to remain in the chosen position.
- * The head of this arm complies with the standard for mounting screens: VESA MIS-D 75 mm and 100 mm.
- * Compatible with screens whose weight does not exceed 10 - 11,5 Kg.
- * Touch screen stability.
- * Screen tilt: 10°. * Screen rotation: 110° right, 110° left.
- * Arm rotation: 105° to the right, 105° to the left.
- * Height adjustment: 45° down, 45° up * Total length 821-916 mm
- * Foldable and removable keyboard and mouse holder: 300 x 210 mm
- * Compatible with multimedia terminals (TMM)
- * Color RAL 7024 (Graphite Grey) and White
- * All our medical arms are in conformity: CE, ROHS, Medical Grade, Regulations MDD 93/42 ECC.
- * Warranty: 5 years

Note: This arm can also be installed on one of our medical columns or trolleys.

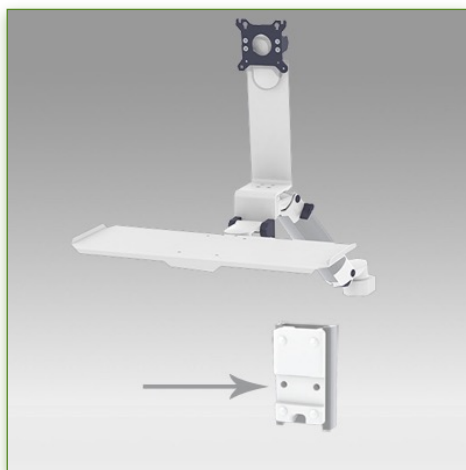

Display Compatibility: 26" Wide (Weight)
Supported Weight: 10- 11,5 Kg
VESA standard: 75 / 100 mm
Keyboard-Mouse holder: 300 x 210 mm

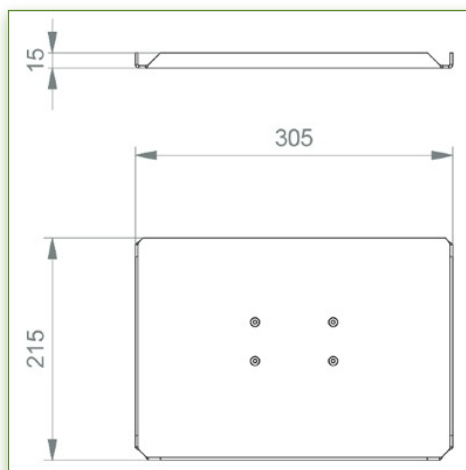
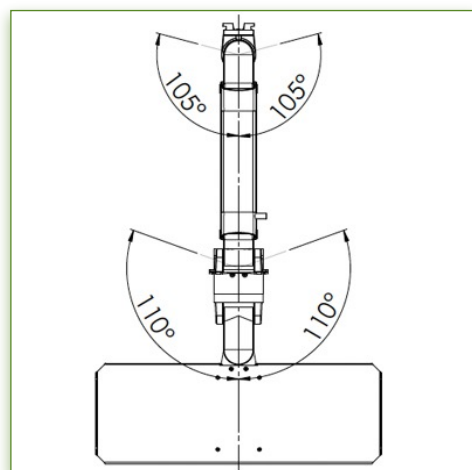
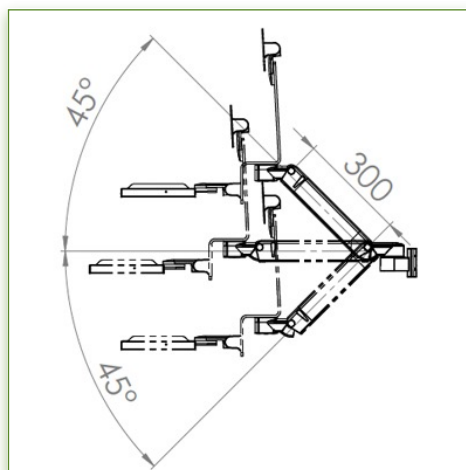
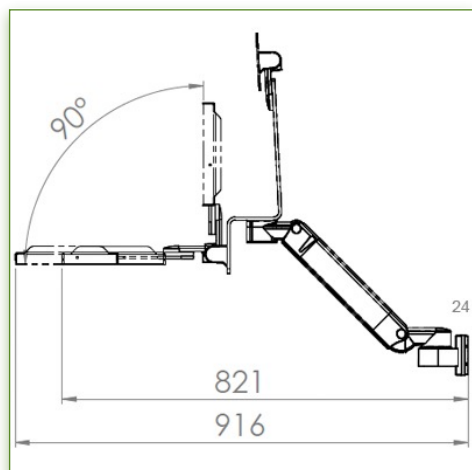
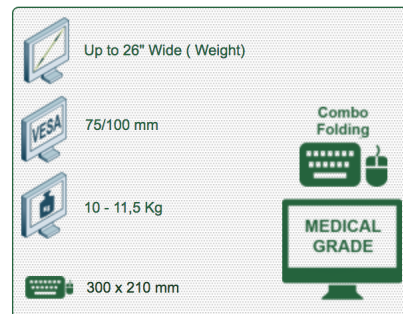

Do not hesitate to contact us if you have any questions about this product.

Warranty: 5 years

000.991.683-4-1

Graphite Grey and White

On Measure

= Depending on the elements

991.683-4-1

Anti-bacterial properties:

IT medical arms are now designed with Microban antibacterial protection, a revolutionary treatment that guarantees optimal hygiene. IT medical arms integrate Microban and other antibacterial agents into all medical products. It inhibits the growth of bacteria of all types. This is not a surface treatment. It is 100% in the totality of the product. It does not alter the physico-mechanical properties of the medical arm lift system. Simulations over 30 years show that 100% of the antibacterial properties are maintained. All medical articulated arms incorporate Microban. Microban is the world's leading provider of anti-bacterial solutions. It has been successfully applied for more than 35 years in a wide range of products used in the hospital, construction and food industries.

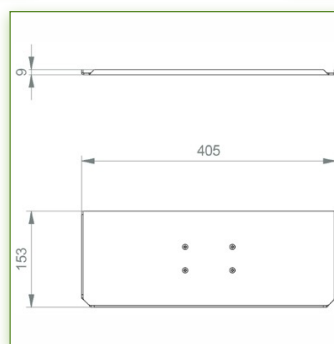
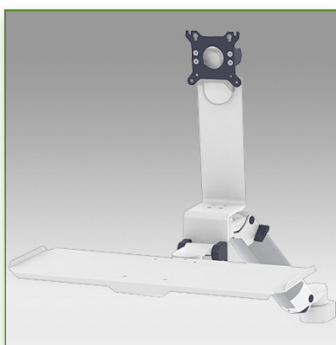

Display Compatibility: 26" Wide (Weight)
Supported Weight: 10- 11,5 Kg
VESA standard: 75 / 100 mm
Keyboard-Mouse holder: 400 x 150 mm

Up to 26" Wide (Weight)
75/100 mm
10 - 11,5 Kg
400 x 150 mm

Combo Folding
MEDICAL GRADE

Do not hesitate to contact us if you have any questions about this product.

Warranty: 5 years

000.991.683-4-2

Graphite Grey and White

On Measure

= Depending on the elements

991.683-4-2

300 mm height-adjustable Medical Combo Folding Arm for monitor, keyboard and mouse, wall mounting on vertical sliding rail

This 300 mm Folding Combo Medical Arm with gas spring height adjustment allows the LCD screen to be perfectly fixed, oriented and adjusted and supports the keyboard and mouse. It is coated with an anti-microbial agent offering hygiene and cleaning down to the last detail. Its modern design has been specially designed for healthcare environments.

Technical specifications:

- * Integrated cable channel
- * Equipotential bonding
- * Optional Vertical Wall Slide Rail Mounting available in several lengths (480 mm - 720 mm - 960 mm - 1200 mm).
- * These wall rails can be easily cut to the required size. All cables also pass through the wall rail. (See Options below)
- * This 300 mm Combo Folding Arm with gas spring simply slides into the wall rail to adjust to the desired height and fixed.
- * It has a safety height adjustment stop button, which allows the arm to remain in the chosen position.
- * The head of this arm complies with the standard for mounting screens: VESA MIS-D 75 mm and 100 mm.
- * Compatible with screens whose weight does not exceed 10 - 11,5 Kg.
- * Touch screen stability.
- * Screen tilt: 10°. * Screen rotation: 110° right, 110° left.
- * Arm rotation: 105° to the right, 105° to the left.
- * Height adjustment: 45° down, 45° up * Total length 821-916 mm
- * Foldable and removable keyboard and mouse holder: 400 x 150 mm
- * Compatible with multimedia terminals (TMM)
- * Color RAL 7024 (Graphite Grey) and White
- * All our medical arms are in conformity: CE, ROHS, Medical Grade, Regulations MDD 93/42 ECC.
- * Warranty: 5 years

Note: This arm can also be installed on one of our medical columns or trolleys.

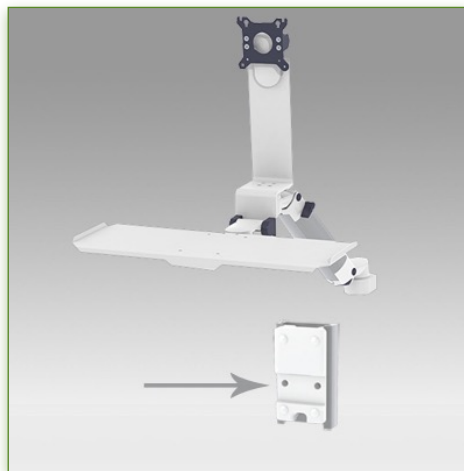

Display Compatibility: 26" Wide (Weight)
Supported Weight: 10- 11,5 Kg
VESA standard: 75 / 100 mm
Keyboard-Mouse holder: 400 x 150 mm

 Up to 26" Wide (Weight)
 75/100 mm
 10 - 11,5 Kg
 400 x 150 mm
MEDICAL GRADE

Do not hesitate to contact us if you have any questions about this product.

Warranty: 5 years

000.991.683-4-2

Graphite Grey and White

On Measure

= Depending on the elements

991.683-4-2

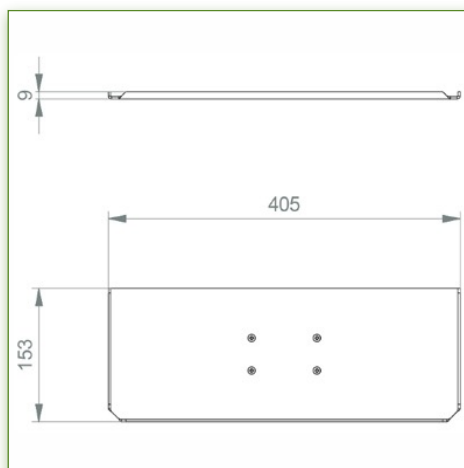
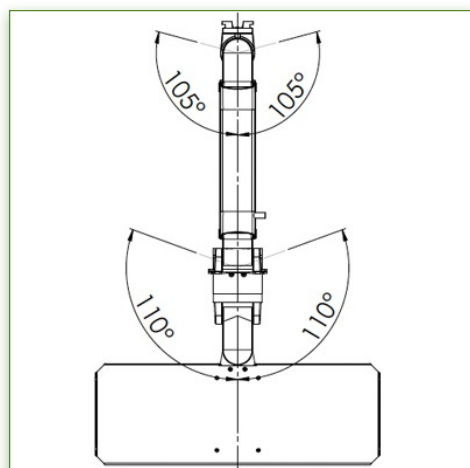
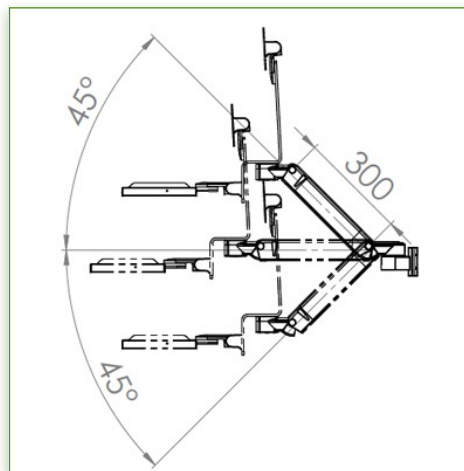
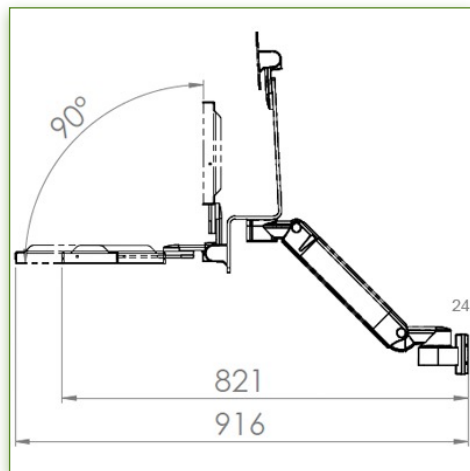

Anti-bacterial properties:

IT medical arms are now designed with Microban antibacterial protection, a revolutionary treatment that guarantees optimal hygiene. IT medical arms integrate Microban and other antibacterial agents into all medical products. It inhibits the growth of bacteria of all types. This is not a surface treatment. It is 100% in the totality of the product. It does not alter the physico-mechanical properties of the medical arm lift system. Simulations over 30 years show that 100% of the antibacterial properties are maintained. All medical articulated arms incorporate Microban. Microban is the world's leading provider of anti-bacterial solutions. It has been successfully applied for more than 35 years in a wide range of products used in the hospital, construction and food industries.

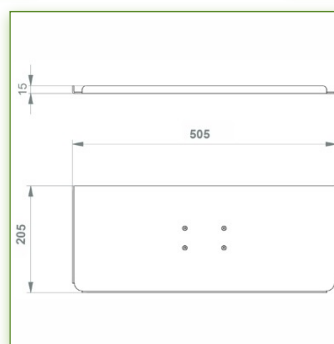
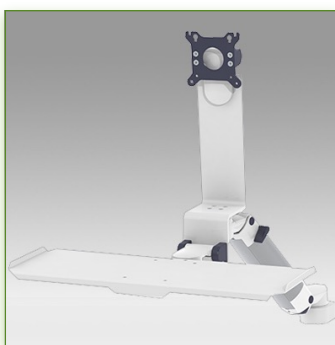

Display Compatibility: 26" Wide (Weight)
Supported Weight: 10- 11,5 Kg
VESA standard: 75 / 100 mm
Keyboard-Mouse holder: 500 x 200 mm

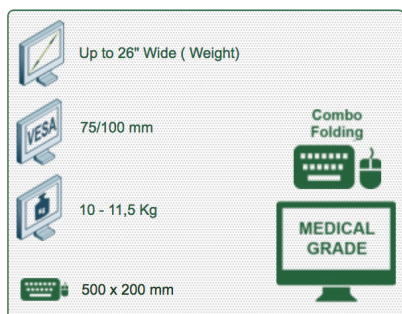

Do not hesitate to contact us if you have any questions about this product.

Warranty: 5 years

000.991.683-4-3

Graphite Grey and White

On Measure

= Depending on the elements

991.683-4-3

300 mm height-adjustable Medical Combo Folding Arm for monitor, keyboard and mouse, wall mounting on vertical sliding rail

This 300 mm Folding Combo Medical Arm with gas spring height adjustment allows the LCD screen to be perfectly fixed, oriented and adjusted and supports the keyboard and mouse. It is coated with an anti-microbial agent offering hygiene and cleaning down to the last detail. Its modern design has been specially designed for healthcare environments.

Technical specifications:

- * Integrated cable channel
- * Equipotential bonding
- * Optional Vertical Wall Slide Rail Mounting available in several lengths (480 mm - 720 mm - 960 mm - 1200 mm).
- * These wall rails can be easily cut to the required size. All cables also pass through the wall rail. (See Options below)
- * This 300 mm Combo Folding Arm with gas spring simply slides into the wall rail to adjust to the desired height and fixed.
- * It has a safety height adjustment stop button, which allows the arm to remain in the chosen position.
- * The head of this arm complies with the standard for mounting screens: VESA MIS-D 75 mm and 100 mm.
- * Compatible with screens whose weight does not exceed 10 - 11,5 Kg.
- * Touch screen stability.
- * Screen tilt: 10°. * Screen rotation: 110° right, 110° left.
- * Arm rotation: 105° to the right, 105° to the left.
- * Height adjustment: 45° down, 45° up * Total length 821-916 mm
- * Foldable and removable keyboard and mouse holder: 500 x 200 mm
- * Compatible with multimedia terminals (TMM)
- * Color RAL 7024 (Graphite Grey) and White
- * All our medical arms are in conformity: CE, ROHS, Medical Grade, Regulations MDD 93/42 ECC.
- * Warranty: 5 years

Note: This arm can also be installed on one of our medical columns or trolleys.

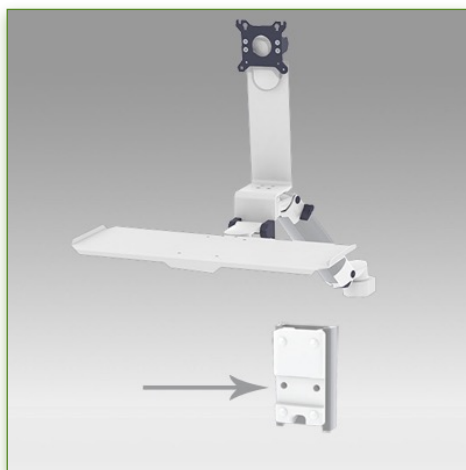
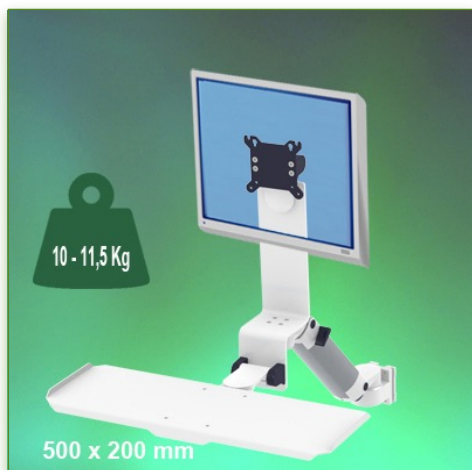

Display Compatibility: 26" Wide (Weight)
Supported Weight: 10- 11,5 Kg
VESA standard: 75 / 100 mm
Keyboard-Mouse holder: 500 x 200 mm

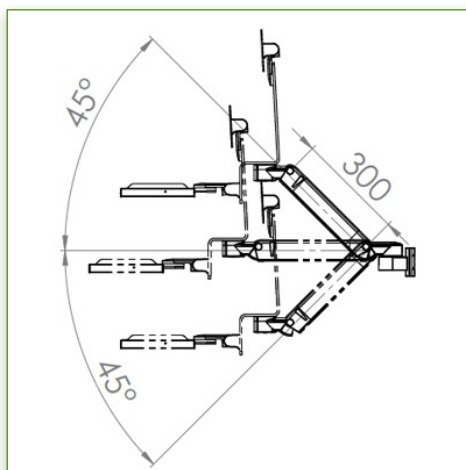
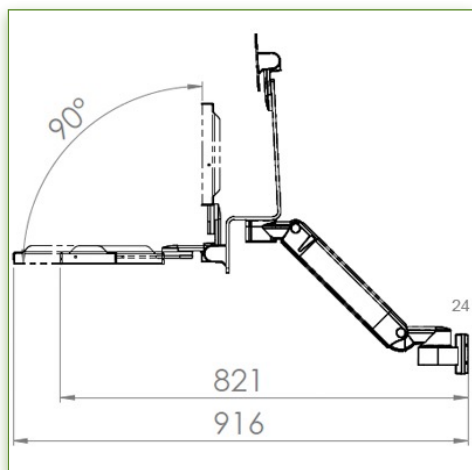
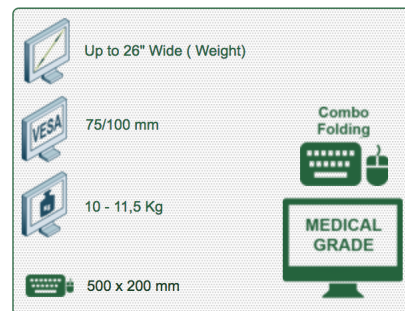

Do not hesitate to contact us if you have any questions about this product.

Warranty: 5 years

000.991.683-4-3

Graphite Grey and White

On Measure

= Depending on the elements

991.683-4-3

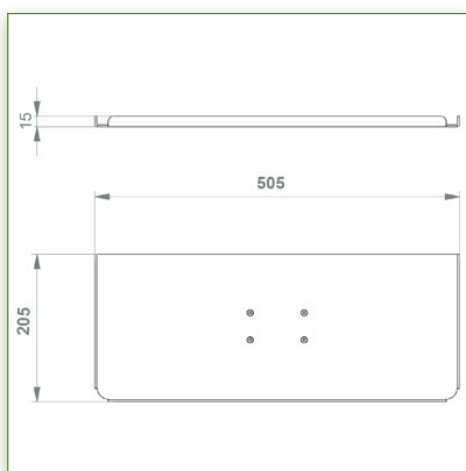
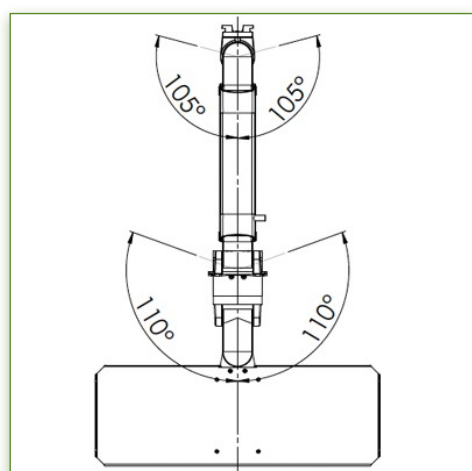

Anti-bacterial properties:

IT medical arms are now designed with Microban antibacterial protection, a revolutionary treatment that guarantees optimal hygiene. IT medical arms integrate Microban and other antibacterial agents into all medical products. It inhibits the growth of bacteria of all types. This is not a surface treatment. It is 100% in the totality of the product. It does not alter the physico-mechanical properties of the medical arm lift system. Simulations over 30 years show that 100% of the antibacterial properties are maintained. All medical articulated arms incorporate Microban. Microban is the world's leading provider of anti-bacterial solutions. It has been successfully applied for more than 35 years in a wide range of products used in the hospital, construction and food industries.

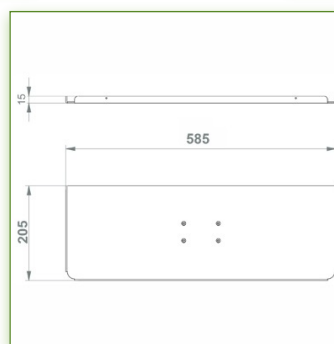
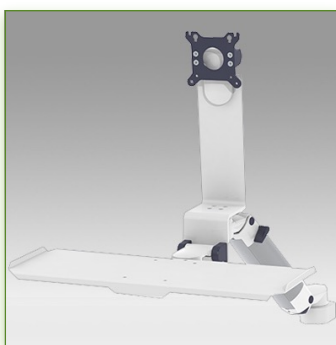

Display Compatibility: 26" Wide (Weight)
Supported Weight: 10- 11,5 Kg
VESA standard: 75 / 100 mm
Keyboard-Mouse holder: 580 x 200 mm

Up to 26" Wide (Weight)
75/100 mm
10 - 11,5 Kg
580 x 200 mm

Combo Folding
MEDICAL GRADE

Do not hesitate to contact us if you have any questions about this product.

Warranty: 5 years

000.991.683-4-4

Graphite Grey and White

On Measure

= Depending on the elements

991.683-4-4

300 mm height-adjustable Medical Combo Folding Arm for monitor, keyboard and mouse, wall mounting on vertical sliding rail

This 300 mm Folding Combo Medical Arm with gas spring height adjustment allows the LCD screen to be perfectly fixed, oriented and adjusted and supports the keyboard and mouse. It is coated with an anti-microbial agent offering hygiene and cleaning down to the last detail. Its modern design has been specially designed for healthcare environments.

Technical specifications:

- * Integrated cable channel
- * Equipotential bonding
- * Optional Vertical Wall Slide Rail Mounting available in several lengths (480 mm - 720 mm - 960 mm - 1200 mm).
- * These wall rails can be easily cut to the required size. All cables also pass through the wall rail. (See Options below)
- * This 300 mm Combo Folding Arm with gas spring simply slides into the wall rail to adjust to the desired height and fixed.
- * It has a safety height adjustment stop button, which allows the arm to remain in the chosen position.
- * The head of this arm complies with the standard for mounting screens: VESA MIS-D 75 mm and 100 mm.
- * Compatible with screens whose weight does not exceed 10 - 11,5 Kg.
- * Touch screen stability.
- * Screen tilt: 10°. * Screen rotation: 110° right, 110° left.
- * Arm rotation: 105° to the right, 105° to the left.
- * Height adjustment: 45° down, 45° up * Total length 821-916 mm
- * Foldable and removable keyboard and mouse holder: 580 x 200 mm
- * Compatible with multimedia terminals (TMM)
- * Color RAL 7024 (Graphite Grey) and White
- * All our medical arms are in conformity: CE, ROHS, Medical Grade, Regulations MDD 93/42 ECC.
- * Warranty: 5 years

Note: This arm can also be installed on one of our medical columns or trolleys.



Display Compatibility: 26" Wide (Weight)
Supported Weight: 10- 11,5 Kg
VESA standard: 75 / 100 mm
Keyboard-Mouse holder: 580 x 200 mm

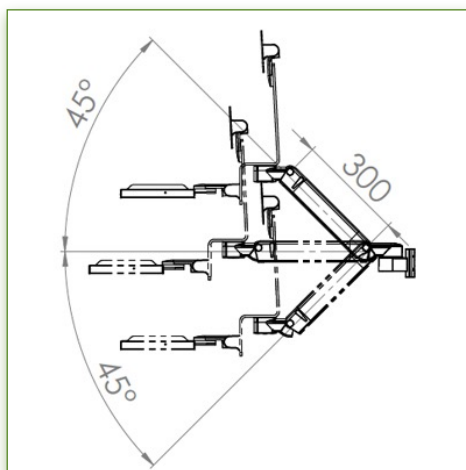
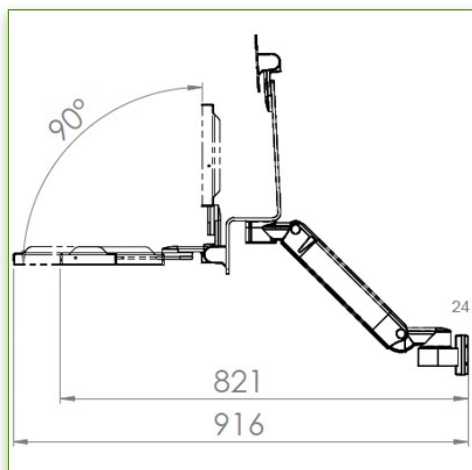
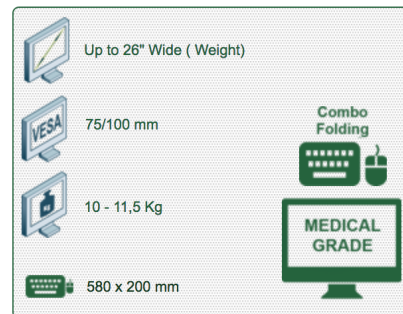

Do not hesitate to contact us if you have any questions about this product.

Warranty: 5 years

000.991.683-4-4

Graphite Grey and White

On Measure

= Depending on the elements

991.683-4-4

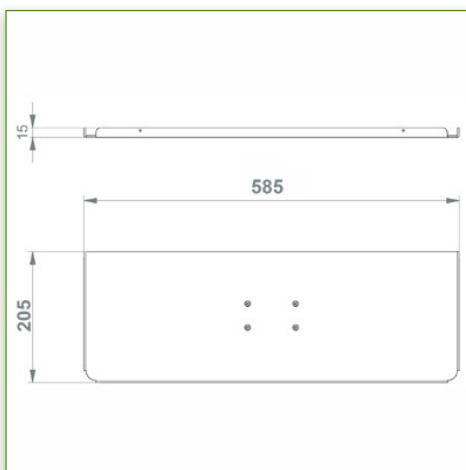
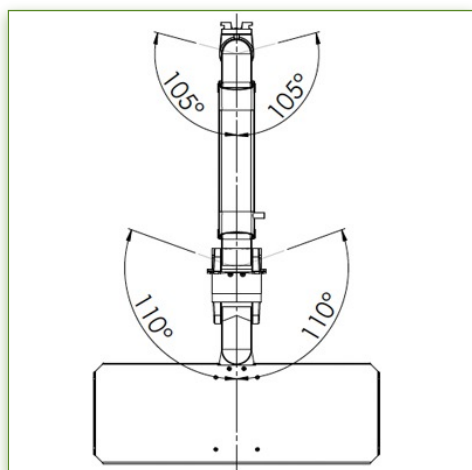

Anti-bacterial properties:

IT medical arms are now designed with Microban antibacterial protection, a revolutionary treatment that guarantees optimal hygiene. IT medical arms integrate Microban and other antibacterial agents into all medical products. It inhibits the growth of bacteria of all types. This is not a surface treatment. It is 100% in the totality of the product. It does not alter the physico-mechanical properties of the medical arm lift system. Simulations over 30 years show that 100% of the antibacterial properties are maintained. All medical articulated arms incorporate Microban. Microban is the world's leading provider of anti-bacterial solutions. It has been successfully applied for more than 35 years in a wide range of products used in the hospital, construction and food industries.

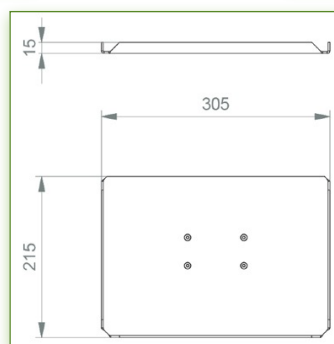
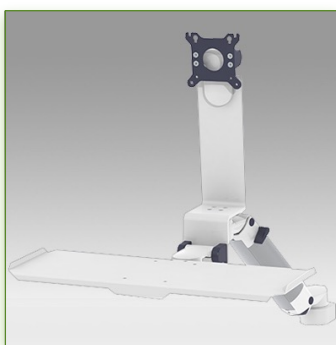

Display Compatibility: 26" Wide (Weight)
Supported Weight: 11- 15,5 Kg
VESA standard: 75 / 100 mm
Keyboard-Mouse holder: 300 x 210 mm

Up to 26" Wide (Weight)
75/100 mm
11 - 15,5 Kg
300 x 210 mm

Combo Folding
MEDICAL GRADE

Do not hesitate to contact us if you have any questions about this product.

Warranty: 5 years

000.991.683-5-1

Graphite Grey and White

On Measure

= Depending on the elements

991.683-5-1

300 mm height-adjustable Medical Combo Folding Arm for monitor, keyboard and mouse, wall mounting on vertical sliding rail

This 300 mm Folding Combo Medical Arm with gas spring height adjustment allows the LCD screen to be perfectly fixed, oriented and adjusted and supports the keyboard and mouse. It is coated with an anti-microbial agent offering hygiene and cleaning down to the last detail. Its modern design has been specially designed for healthcare environments.

Technical specifications:

- * Integrated cable channel
- * Equipotential bonding
- * Optional Vertical Wall Slide Rail Mounting available in several lengths (480 mm - 720 mm - 960 mm - 1200 mm).
- * These wall rails can be easily cut to the required size. All cables also pass through the wall rail. (See Options below)
- * This 300 mm Combo Folding Arm with gas spring simply slides into the wall rail to adjust to the desired height and fixed.
- * It has a safety height adjustment stop button, which allows the arm to remain in the chosen position.
- * The head of this arm complies with the standard for mounting screens: VESA MIS-D 75 mm and 100 mm.
- * Compatible with screens whose weight does not exceed 11 - 15,5 Kg.
- * Touch screen stability.
- * Screen tilt: 10°. * Screen rotation: 110° right, 110° left.
- * Arm rotation: 105° to the right, 105° to the left.
- * Height adjustment: 45° down, 45° up * Total length 821-916 mm
- * Foldable and removable keyboard and mouse holder: 300 x 210 mm
- * Compatible with multimedia terminals (TMM)
- * Color RAL 7024 (Graphite Grey) and White
- * All our medical arms are in conformity: CE, ROHS, Medical Grade, Regulations MDD 93/42 ECC.
- * Warranty: 5 years

Note: This arm can also be installed on one of our medical columns or trolleys.

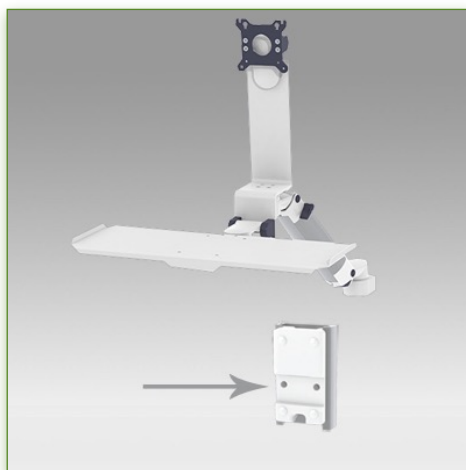

Display Compatibility: 26" Wide (Weight)
Supported Weight: 11- 15,5 Kg
VESA standard: 75 / 100 mm
Keyboard-Mouse holder: 300 x 210 mm

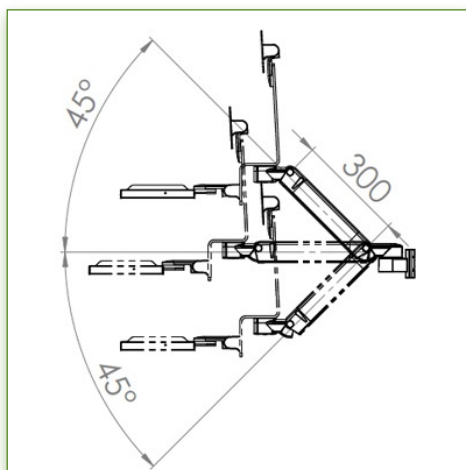
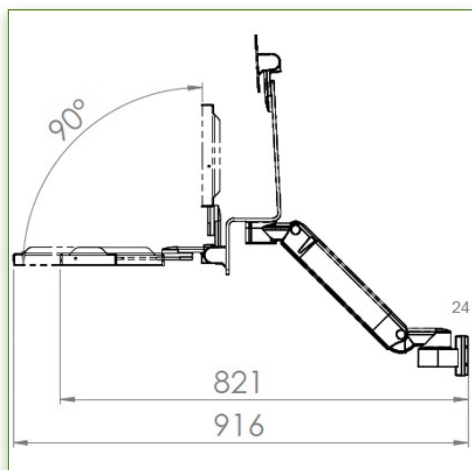
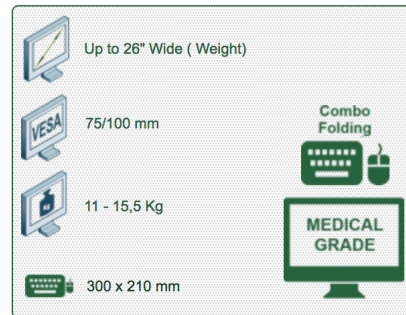

Do not hesitate to contact us if you have any questions about this product.

- Warranty: 5 years
- 000.991.683-5-1
- Graphite Grey and White
- On Measure
- = Depending on the elements
- 991.683-5-1

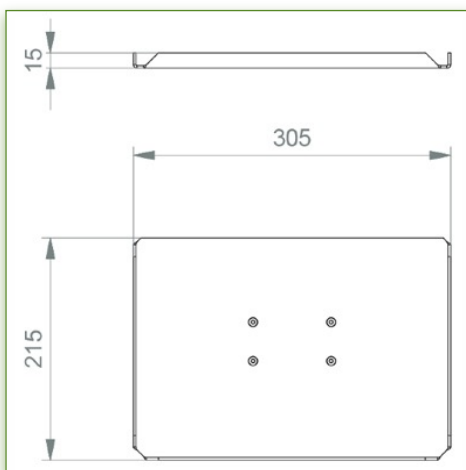
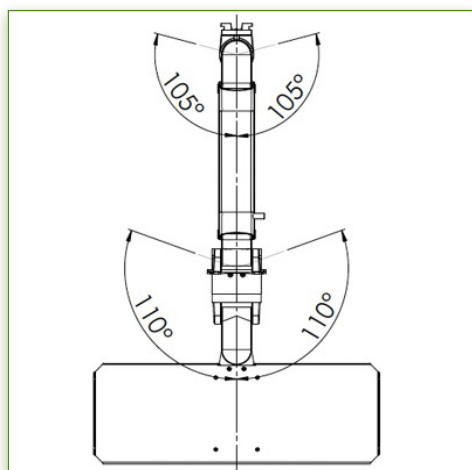

Anti-bacterial properties:

IT medical arms are now designed with Microban antibacterial protection, a revolutionary treatment that guarantees optimal hygiene. IT medical arms integrate Microban and other antibacterial agents into all medical products. It inhibits the growth of bacteria of all types. This is not a surface treatment. It is 100% in the totality of the product. It does not alter the physico-mechanical properties of the medical arm lift system. Simulations over 30 years show that 100% of the antibacterial properties are maintained. All medical articulated arms incorporate Microban. Microban is the world's leading provider of anti-bacterial solutions. It has been successfully applied for more than 35 years in a wide range of products used in the hospital, construction and food industries.

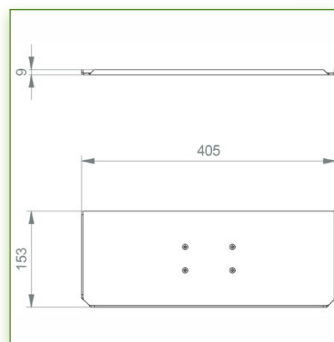
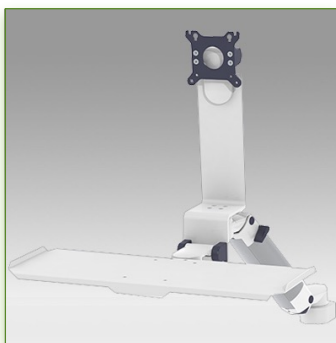

Display Compatibility: 26" Wide (Weight)
Supported Weight: 11- 15,5 Kg
VESA standard: 75 / 100 mm
Keyboard-Mouse holder: 400 x 150 mm

Up to 26" Wide (Weight)

75/100 mm

11 - 15,5 Kg

400 x 150 mm

Combo Folding

MEDICAL GRADE

Do not hesitate to contact us if you have any questions about this product.

Warranty: 5 years

000.991.683-5-2

Graphite Grey and White

On Measure

= Depending on the elements

991.683-5-2

300 mm height-adjustable Medical Combo Folding Arm for monitor, keyboard and mouse, wall mounting on vertical sliding rail

This 300 mm Folding Combo Medical Arm with gas spring height adjustment allows the LCD screen to be perfectly fixed, oriented and adjusted and supports the keyboard and mouse. It is coated with an anti-microbial agent offering hygiene and cleaning down to the last detail. Its modern design has been specially designed for healthcare environments.

Technical specifications:

- * Integrated cable channel
- * Equipotential bonding
- * Optional Vertical Wall Slide Rail Mounting available in several lengths (480 mm - 720 mm - 960 mm - 1200 mm).
- * These wall rails can be easily cut to the required size. All cables also pass through the wall rail. (See Options below)
- * This 300 mm Combo Folding Arm with gas spring simply slides into the wall rail to adjust to the desired height and fixed.
- * It has a safety height adjustment stop button, which allows the arm to remain in the chosen position.
- * The head of this arm complies with the standard for mounting screens: VESA MIS-D 75 mm and 100 mm.
- * Compatible with screens whose weight does not exceed 11 - 15,5 Kg.
- * Touch screen stability.
- * Screen tilt: 10°. * Screen rotation: 110° right, 110° left.
- * Arm rotation: 105° to the right, 105° to the left.
- * Height adjustment: 45° down, 45° up * Total length 821-916 mm
- * Foldable and removable keyboard and mouse holder: 400 x 150 mm
- * Compatible with multimedia terminals (TMM)
- * Color RAL 7024 (Graphite Grey) and White
- * All our medical arms are in conformity: CE, ROHS, Medical Grade, Regulations MDD 93/42 ECC.
- * Warranty: 5 years

Note: This arm can also be installed on one of our medical columns or trolleys.



Display Compatibility: 26" Wide (Weight)
Supported Weight: 11- 15,5 Kg
VESA standard: 75 / 100 mm
Keyboard-Mouse holder: 400 x 150 mm

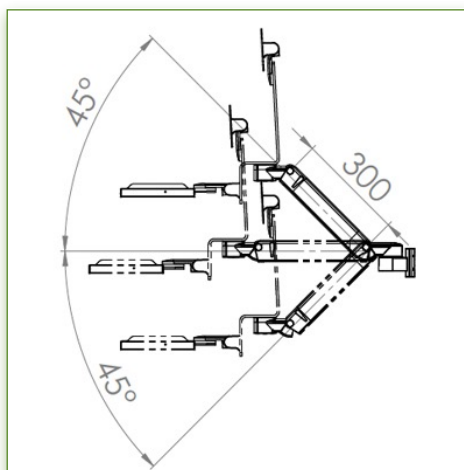
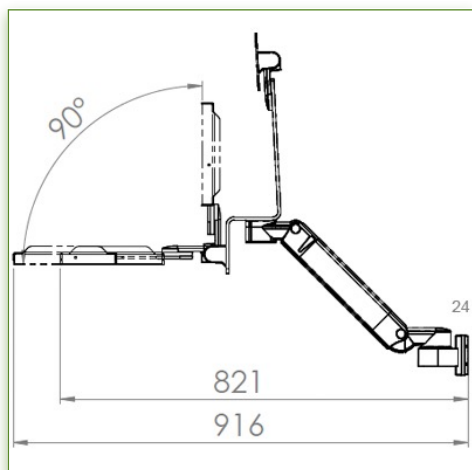
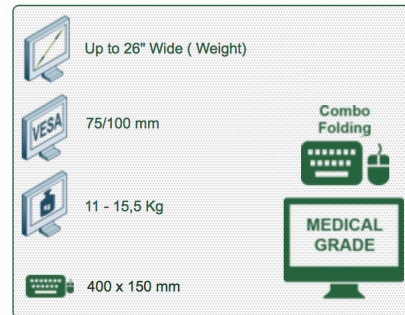

Do not hesitate to contact us if you have any questions about this product.

Warranty: 5 years

000.991.683-5-2

Graphite Grey and White

On Measure

= Depending on the elements

991.683-5-2

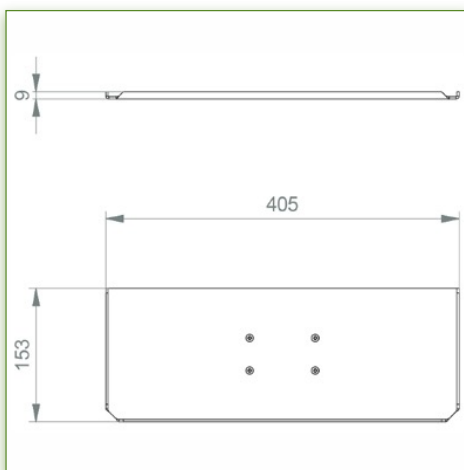
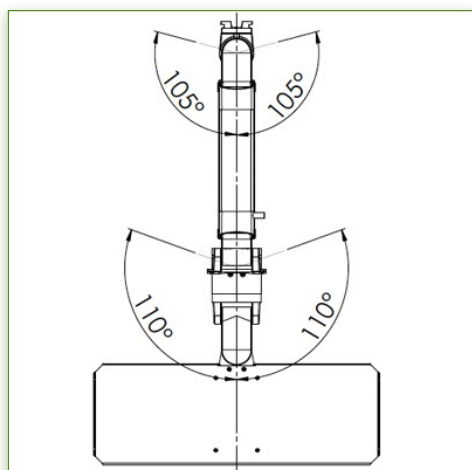

Anti-bacterial properties:

IT medical arms are now designed with Microban antibacterial protection, a revolutionary treatment that guarantees optimal hygiene. IT medical arms integrate Microban and other antibacterial agents into all medical products. It inhibits the growth of bacteria of all types. This is not a surface treatment.

It is 100% in the totality of the product. It does not alter the physico-mechanical properties of the medical arm lift system. Simulations over 30 years show that 100% of the antibacterial properties are maintained.

All medical articulated arms incorporate Microban. Microban is the world's leading provider of anti-bacterial solutions. It has been successfully applied for more than 35 years in a wide range of products used in the hospital, construction and food industries.

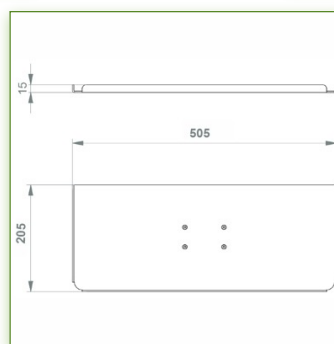
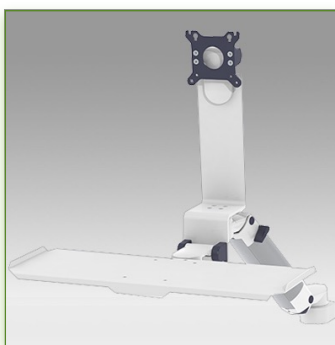
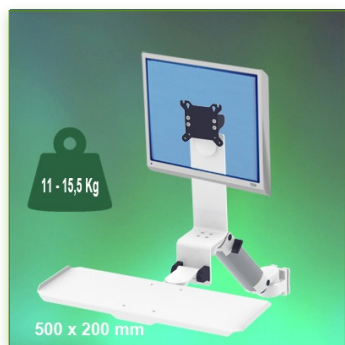

Display Compatibility: 26" Wide (Weight)
Supported Weight: 11- 15,5 Kg
VESA standard: 75 / 100 mm
Keyboard-Mouse holder: 500 x 200 mm

 Up to 26" Wide (Weight)
 75/100 mm
 11 - 15,5 Kg
 500 x 200 mm

Do not hesitate to contact us if you have any questions about this product.

Warranty: 5 years

000.991.683-5-3

Graphite Grey and White

On Measure

= Depending on the elements

991.683-5-3

300 mm height-adjustable Medical Combo Folding Arm for monitor, keyboard and mouse, wall mounting on vertical sliding rail

This 300 mm Folding Combo Medical Arm with gas spring height adjustment allows the LCD screen to be perfectly fixed, oriented and adjusted and supports the keyboard and mouse. It is coated with an anti-microbial agent offering hygiene and cleaning down to the last detail. Its modern design has been specially designed for healthcare environments.

Technical specifications:

- * Integrated cable channel
- * Equipotential bonding
- * Optional Vertical Wall Slide Rail Mounting available in several lengths (480 mm - 720 mm - 960 mm - 1200 mm).
- * These wall rails can be easily cut to the required size. All cables also pass through the wall rail. (See Options below)
- * This 300 mm Combo Folding Arm with gas spring simply slides into the wall rail to adjust to the desired height and fixed.
- * It has a safety height adjustment stop button, which allows the arm to remain in the chosen position.
- * The head of this arm complies with the standard for mounting screens: VESA MIS-D 75 mm and 100 mm.
- * Compatible with screens whose weight does not exceed 11 - 15,5 Kg.
- * Touch screen stability.
- * Screen tilt: 10°. * Screen rotation: 110° right, 110° left.
- * Arm rotation: 105° to the right, 105° to the left.
- * Height adjustment: 45° down, 45° up * Total length 821-916 mm
- * Foldable and removable keyboard and mouse holder: 500 x 200 mm
- * Compatible with multimedia terminals (TMM)
- * Color RAL 7024 (Graphite Grey) and White
- * All our medical arms are in conformity: CE, ROHS, Medical Grade, Regulations MDD 93/42 ECC.
- * Warranty: 5 years

Note: This arm can also be installed on one of our medical columns or trolleys.

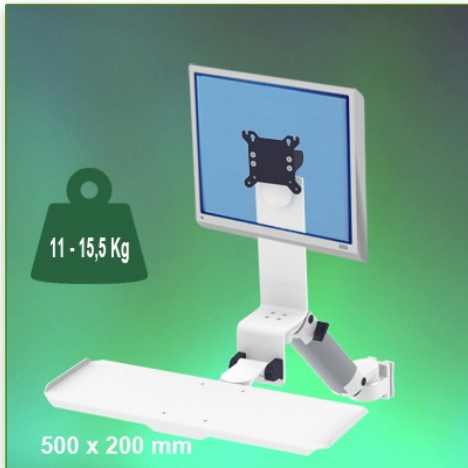

Display Compatibility: 26" Wide (Weight)
Supported Weight: 11- 15.5 Kg
VESA standard: 75 / 100 mm
Keyboard-Mouse holder: 500 x 200 mm

Up to 26" Wide (Weight)
75/100 mm
11 - 15,5 Kg
500 x 200 mm

Combo Folding
MEDICAL GRADE

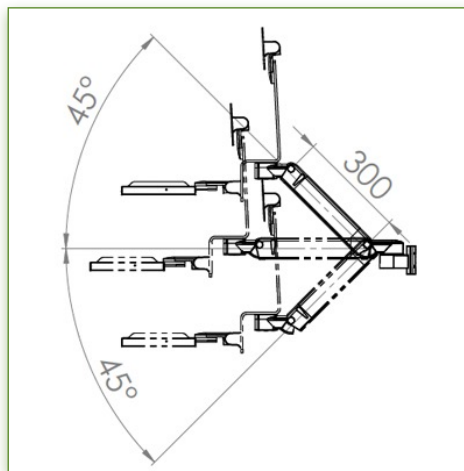
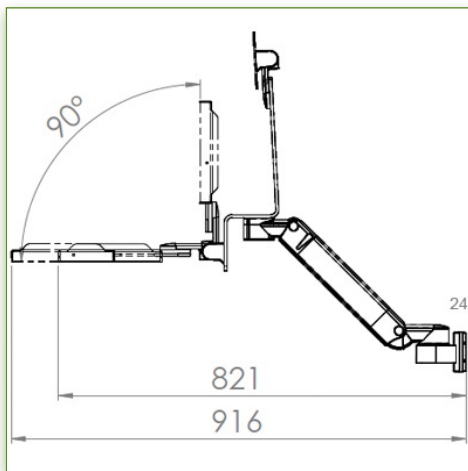

Do not hesitate to contact us if you have any questions about this product.

- Warranty: 5 years
- 000.991.683-5-3
- Graphite Grey and White
- On Measure
- = Depending on the elements
- 991.683-5-3

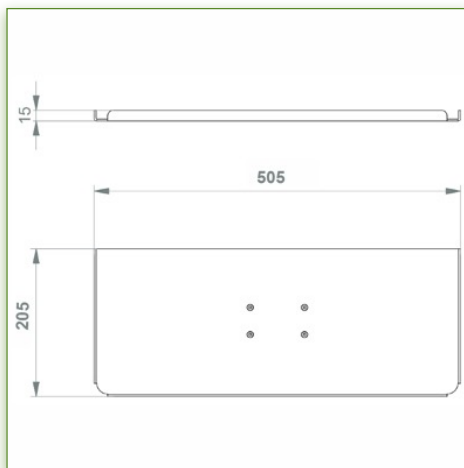
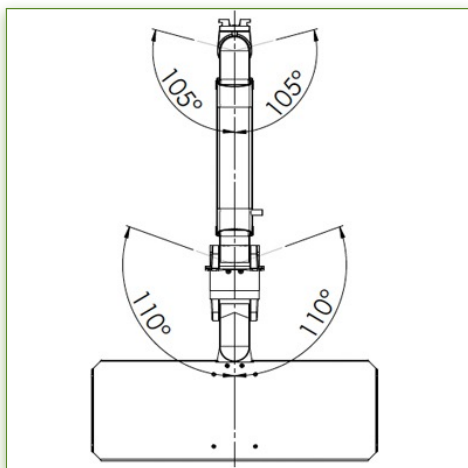

Anti-bacterial properties:

IT medical arms are now designed with Microban antibacterial protection, a revolutionary treatment that guarantees optimal hygiene. IT medical arms integrate Microban and other antibacterial agents into all medical products. It inhibits the growth of bacteria of all types. This is not a surface treatment.

It is 100% in the totality of the product. It does not alter the physico-mechanical properties of the medical arm lift system. Simulations over 30 years show that 100% of the antibacterial properties are maintained.

All medical articulated arms incorporate Microban. Microban is the world's leading provider of anti-bacterial solutions. It has been successfully applied for more than 35 years in a wide range of products used in the hospital, construction and food industries.

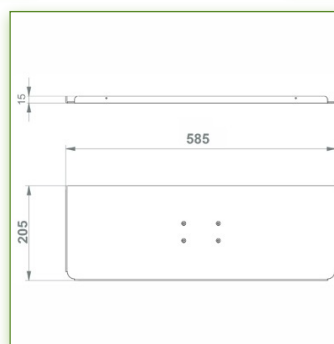

Display Compatibility: 26" Wide (Weight)
Supported Weight: 11- 15,5 Kg
VESA standard: 75 / 100 mm
Keyboard-Mouse holder: 580 x 200 mm

 Up to 26" Wide (Weight)
 75/100 mm
 11 - 15,5 Kg
 580 x 200 mm
 MEDICAL GRADE
 Combo Folding

Do not hesitate to contact us if you have any questions about this product.

Warranty: 5 years

000.991.683-5-4

Graphite Grey and White

On Measure

= Depending on the elements

991.683-5-4

300 mm height-adjustable Medical Combo Folding Arm for monitor, keyboard and mouse, wall mounting on vertical sliding rail

This 300 mm Folding Combo Medical Arm with gas spring height adjustment allows the LCD screen to be perfectly fixed, oriented and adjusted and supports the keyboard and mouse. It is coated with an anti-microbial agent offering hygiene and cleaning down to the last detail. Its modern design has been specially designed for healthcare environments.

Technical specifications:

- * Integrated cable channel
- * Equipotential bonding
- * Optional Vertical Wall Slide Rail Mounting available in several lengths (480 mm - 720 mm - 960 mm - 1200 mm).
- * These wall rails can be easily cut to the required size. All cables also pass through the wall rail. (See Options below)
- * This 300 mm Combo Folding Arm with gas spring simply slides into the wall rail to adjust to the desired height and fixed.
- * It has a safety height adjustment stop button, which allows the arm to remain in the chosen position.
- * The head of this arm complies with the standard for mounting screens: VESA MIS-D 75 mm and 100 mm.
- * Compatible with screens whose weight does not exceed 11 - 15,5 Kg.
- * Touch screen stability.
- * Screen tilt: 10°. * Screen rotation: 110° right, 110° left.
- * Arm rotation: 105° to the right, 105° to the left.
- * Height adjustment: 45° down, 45° up * Total length 821-916 mm
- * Foldable and removable keyboard and mouse holder: 580 x 200 mm
- * Compatible with multimedia terminals (TMM)
- * Color RAL 7024 (Graphite Grey) and White
- * All our medical arms are in conformity: CE, ROHS, Medical Grade, Regulations MDD 93/42 ECC.
- * Warranty: 5 years

Note: This arm can also be installed on one of our medical columns or trolleys.

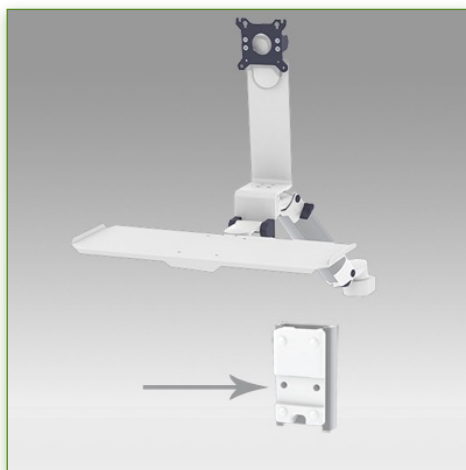

Display Compatibility: 26" Wide (Weight)
Supported Weight: 11- 15,5 Kg
VESA standard: 75 / 100 mm
Keyboard-Mouse holder: 580 x 200 mm

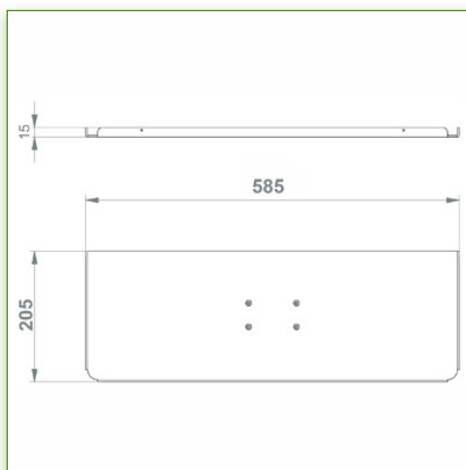
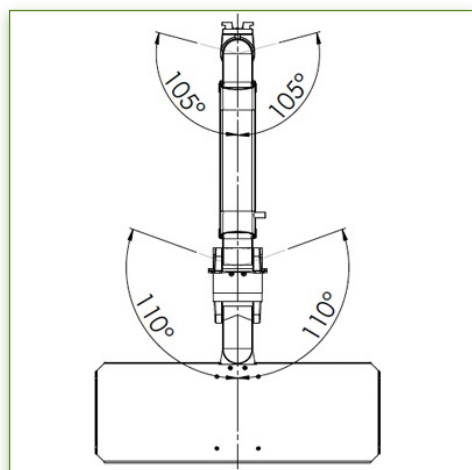
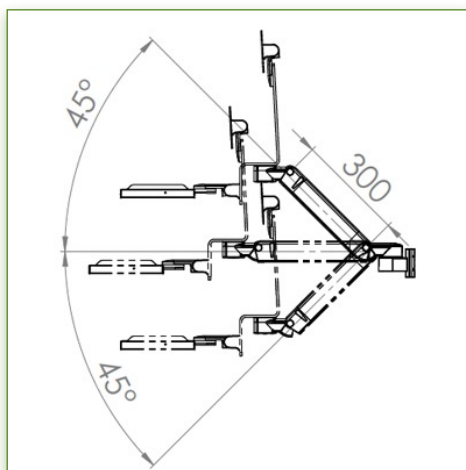
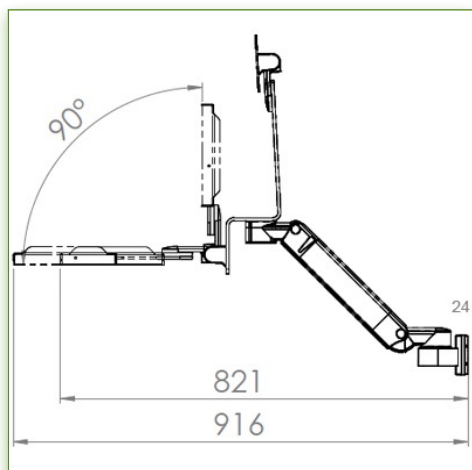
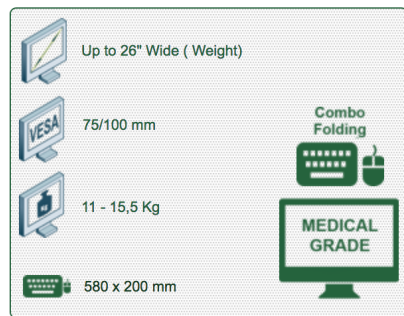

Do not hesitate to contact us if you have any questions about this product.

- Warranty: 5 years
- 000.991.683-5-4
- Graphite Grey and White
- On Measure
- = Depending on the elements
- 991.683-5-4

Anti-bacterial properties:

IT medical arms are now designed with Microban antibacterial protection, a revolutionary treatment that guarantees optimal hygiene. IT medical arms integrate Microban and other antibacterial agents into all medical products. It inhibits the growth of bacteria of all types. This is not a surface treatment. It is 100% in the totality of the product. It does not alter the physico-mechanical properties of the medical arm lift system. Simulations over 30 years show that 100% of the antibacterial properties are maintained. All medical articulated arms incorporate Microban. Microban is the world's leading provider of anti-bacterial solutions. It has been successfully applied for more than 35 years in a wide range of products used in the hospital, construction and food industries.

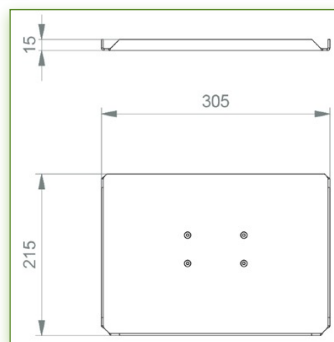
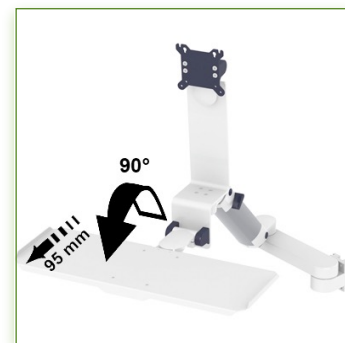

Display Compatibility: 26" Wide (Weight)
Supported Weight: 2- 4,5 Kg
VESA standard: 75 / 100 mm
Keyboard-Mouse holder: 300 x 210 mm

Up to 26" Wide (Weight)
75/100 mm
2 - 4,5 Kg
300 x 210 mm

Combo Folding
MEDICAL GRADE

Do not hesitate to contact us if you have any questions about this product.

Warranty: 5 years

000.991.692-1-1

Graphite Grey and White

On Measure

= Depending on the elements

991.692-1-1

300 + 240 mm height-adjustable Medical Combo Folding Arm for monitor, keyboard and mouse, wall mounting on vertical sliding rail

This 300 + 240 mm Folding Combo Medical Arm with gas spring height adjustment allows the LCD screen to be perfectly fixed, oriented and adjusted and supports the keyboard and mouse. It is coated with an anti-microbial agent offering hygiene and cleaning down to the last detail. Its modern design has been specially designed for healthcare environments.

Technical specifications:

- * Integrated cable channel * Equipotential bonding
- * Optional Vertical Wall Slide Rail Mounting available in several lengths (480 mm - 720 mm - 960 mm - 1200 mm).
- * These wall rails can be easily cut to the required size. All cables also pass through the wall rail. (See Options below)
- * This 300 + 240 mm Combo Folding Arm with gas spring simply slides into the wall rail to adjust to the desired height and fixed.
- * It has a safety height adjustment stop button, which allows the arm to remain in the chosen position.
- * The head of this arm complies with the standard for mounting screens: VESA MIS-D 75 mm and 100 mm.
- * Compatible with screens whose weight does not exceed 2 - 4,5 Kg.
- * Touch screen stability. * Screen tilt: 10°.
- * Screen rotation: 110° right, 110° left.
- * Arm rotation: 105° to the right, 105° to the left.
- * Height adjustment: 45° down, 45° up * Total length 991 - 1086 mm
- * Foldable and removable keyboard and mouse holder: 300 x 210 mm
- * Compatible with multimedia terminals (TMM)
- * Color RAL 7024 (Graphite Grey) and White
- * All our medical arms are in conformity: CE, ROHS, Medical Grade, Regulations MDD 93/42 ECC.
- * Warranty: 5 years

Note: This arm can also be installed on one of our medical columns or trolleys.



Display Compatibility: 26" Wide (Weight)
Supported Weight: 2- 4,5 Kg
VESA standard: 75 / 100 mm
Keyboard-Mouse holder: 300 x 210 mm

Up to 26" Wide (Weight)
75/100 mm
2 - 4,5 Kg
300 x 210 mm

Combo Folding
MEDICAL GRADE



Do not hesitate to contact us if you have any questions about this product.

Warranty: 5 years

000.991.692-1-1

Graphite Grey and White

On Measure

= Depending on the elements

991.692-1-1

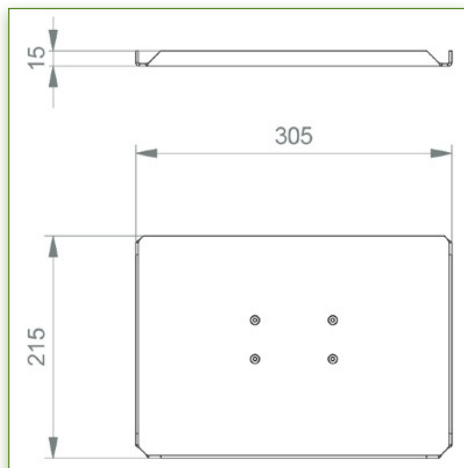
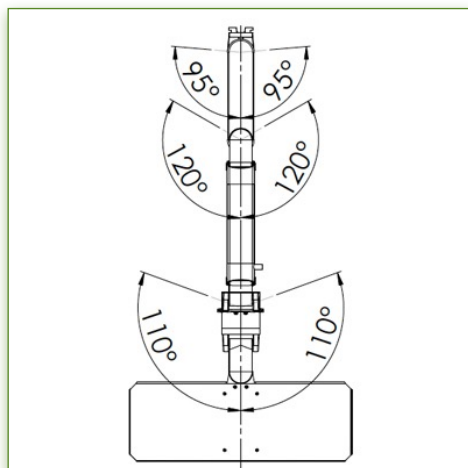
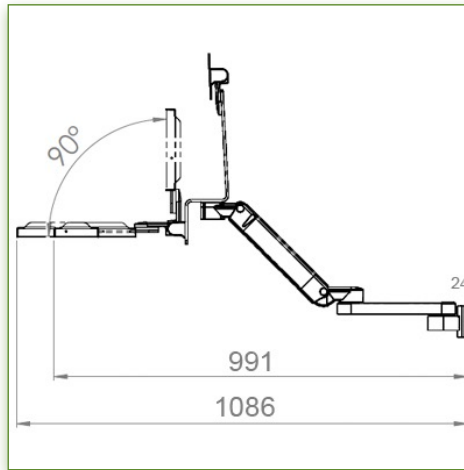
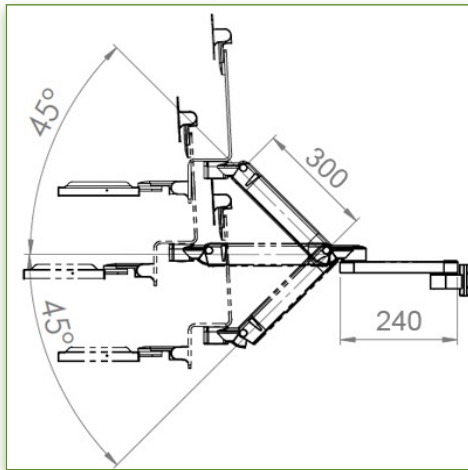

Anti-bacterial properties:

IT medical arms are now designed with Microban antibacterial protection, a revolutionary treatment that guarantees optimal hygiene. IT medical arms integrate Microban and other antibacterial agents into all medical products. It inhibits the growth of bacteria of all types. This is not a surface treatment. It is 100% in the totality of the product. It does not alter the physico-mechanical properties of the medical arm lift system. Simulations over 30 years show that 100% of the antibacterial properties are maintained. All medical articulated arms incorporate Microban. Microban is the world's leading provider of anti-bacterial solutions. It has been successfully applied for more than 35 years in a wide range of products used in the hospital, construction and food industries.

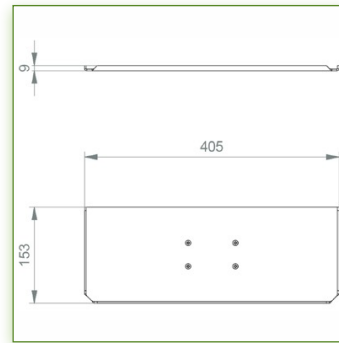
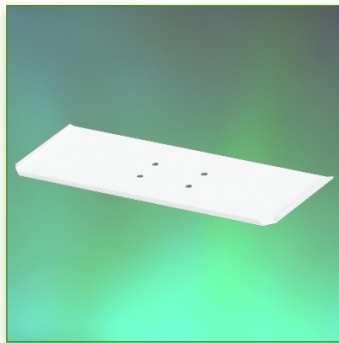
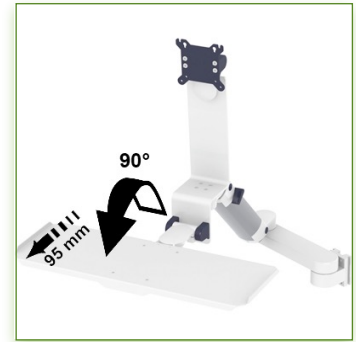
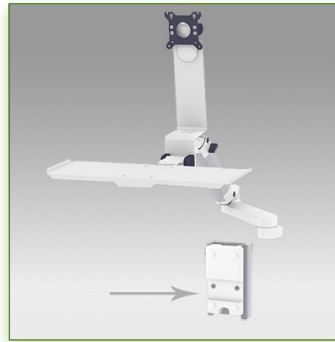

Display Compatibility: 26" Wide (Weight)
Supported Weight: 2- 4,5 Kg
VESA standard: 75 / 100 mm
Keyboard-Mouse holder: 400 x 150 mm

 Up to 26" Wide (Weight)
 75/100 mm
 2 - 4,5 Kg
 400 x 150 mm

Do not hesitate to contact us if you have any questions about this product.

Warranty: 5 years

000.991.692-1-2

Graphite Grey and White

On Measure

= Depending on the elements

991.692-1-2

300 + 240 mm height-adjustable Medical Combo Folding Arm for monitor, keyboard and mouse, wall mounting on vertical sliding rail

This 300 + 240 mm Folding Combo Medical Arm with gas spring height adjustment allows the LCD screen to be perfectly fixed, oriented and adjusted and supports the keyboard and mouse. It is coated with an anti-microbial agent offering hygiene and cleaning down to the last detail. Its modern design has been specially designed for healthcare environments.

Technical specifications:

- * Integrated cable channel
- * Equipotential bonding
- * Optional Vertical Wall Slide Rail Mounting available in several lengths (480 mm - 720 mm - 960 mm - 1200 mm).
- * These wall rails can be easily cut to the required size. All cables also pass through the wall rail. (See Options below)
- * This 300 + 240 mm Combo Folding Arm with gas spring simply slides into the wall rail to adjust to the desired height and fixed.
- * It has a safety height adjustment stop button, which allows the arm to remain in the chosen position.
- * The head of this arm complies with the standard for mounting screens: VESA MIS-D 75 mm and 100 mm.
- * Compatible with screens whose weight does not exceed 2 - 4,5 Kg.
- * Touch screen stability. * Screen tilt: 10°.
- * Screen rotation: 110° right, 110° left.
- * Arm rotation: 105° to the right, 105° to the left.
- * Height adjustment: 45° down, 45° up * Total length 991 - 1086 mm
- * Foldable and removable keyboard and mouse holder: 400 x 150 mm
- * Compatible with multimedia terminals (TMM)
- * Color RAL 7024 (Graphite Grey) and White
- * All our medical arms are in conformity: CE, ROHS, Medical Grade, Regulations MDD 93/42 ECC.
- * Warranty: 5 years

Note: This arm can also be installed on one of our medical columns or trolleys.



Display Compatibility: 26" Wide (Weight)
Supported Weight: 2- 4,5 Kg
VESA standard: 75 / 100 mm
Keyboard-Mouse holder: 400 x 150 mm

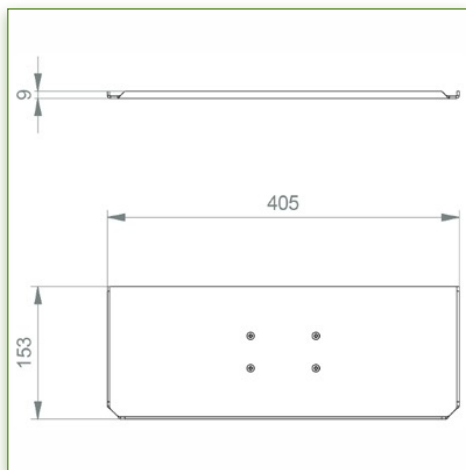
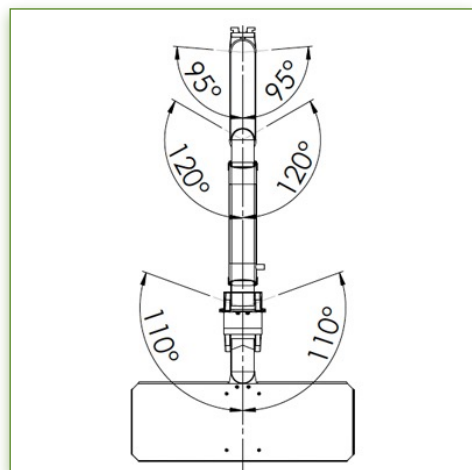
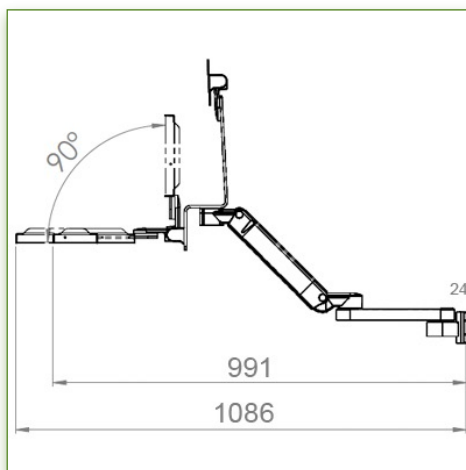
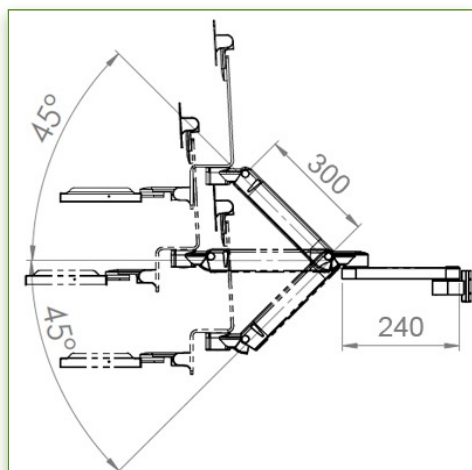
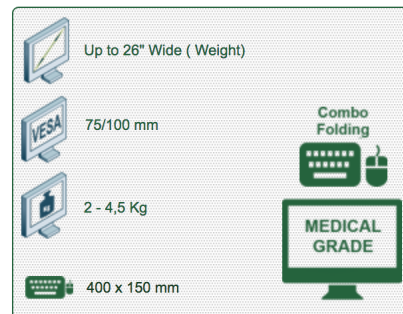

Medical Grade

Do not hesitate to contact us if you have any questions about this product.

- Warranty: 5 years**
- 000.991.692-1-2
- Graphite Grey and White**
- On Measure**
- = Depending on the elements**
- 991.692-1-2**

Anti-bacterial properties:

IT medical arms are now designed with Microban antibacterial protection, a revolutionary treatment that guarantees optimal hygiene. IT medical arms integrate Microban and other antibacterial agents into all medical products. It inhibits the growth of bacteria of all types. This is not a surface treatment. It is 100% in the totality of the product. It does not alter the physico-mechanical properties of the medical arm lift system. Simulations over 30 years show that 100% of the antibacterial properties are maintained. All medical articulated arms incorporate Microban. Microban is the world's leading provider of anti-bacterial solutions. It has been successfully applied for more than 35 years in a wide range of products used in the hospital, construction and food industries.

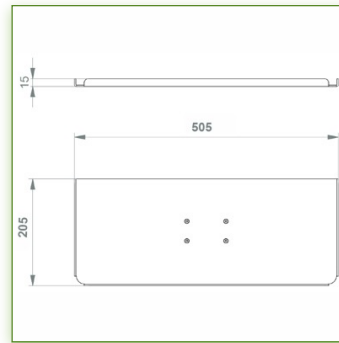
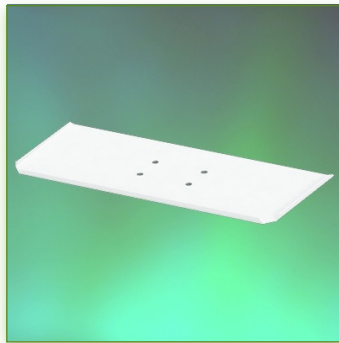
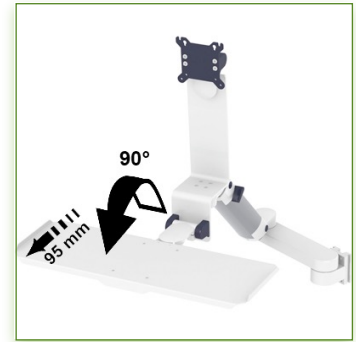

Display Compatibility: 26" Wide (Weight)
Supported Weight: 2- 4,5 Kg
VESA standard: 75 / 100 mm
Keyboard-Mouse holder: 500 x 200 mm

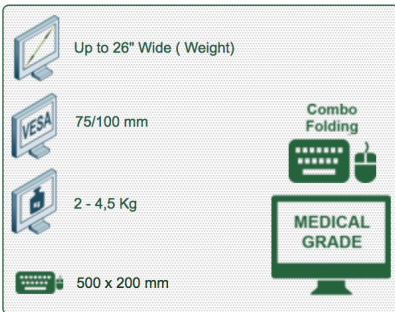

Do not hesitate to contact us if you have any questions about this product.

Warranty: 5 years

000.991.692-1-3

Graphite Grey and White

On Measure

= Depending on the elements

991.692-1-3

300 + 240 mm height-adjustable Medical Combo Folding Arm for monitor, keyboard and mouse, wall mounting on vertical sliding rail

This 300 + 240 mm Folding Combo Medical Arm with gas spring height adjustment allows the LCD screen to be perfectly fixed, oriented and adjusted and supports the keyboard and mouse. It is coated with an anti-microbial agent offering hygiene and cleaning down to the last detail. Its modern design has been specially designed for healthcare environments.

Technical specifications:

- * Integrated cable channel
- * Equipotential bonding
- * Optional Vertical Wall Slide Rail Mounting available in several lengths (480 mm - 720 mm - 960 mm - 1200 mm).
- * These wall rails can be easily cut to the required size. All cables also pass through the wall rail. (See Options below)
- * This 300 + 240 mm Combo Folding Arm with gas spring simply slides into the wall rail to adjust to the desired height and fixed.
- * It has a safety height adjustment stop button, which allows the arm to remain in the chosen position.
- * The head of this arm complies with the standard for mounting screens: VESA MIS-D 75 mm and 100 mm.
- * Compatible with screens whose weight does not exceed 2 - 4,5 Kg.
- * Touch screen stability. * Screen tilt: 10°.
- * Screen rotation: 110° right, 110° left.
- * Arm rotation: 105° to the right, 105° to the left.
- * Height adjustment: 45° down, 45° up * Total length 991 - 1086 mm
- * Foldable and removable keyboard and mouse holder: 500 x 200 mm
- * Compatible with multimedia terminals (TMM)
- * Color RAL 7024 (Graphite Grey) and White
- * All our medical arms are in conformity: CE, ROHS, Medical Grade, Regulations MDD 93/42 ECC.
- * Warranty: 5 years

Note: This arm can also be installed on one of our medical columns or trolleys.



Display Compatibility: 26" Wide (Weight)
Supported Weight: 2- 4,5 Kg
VESA standard: 75 / 100 mm
Keyboard-Mouse holder: 500 x 200 mm

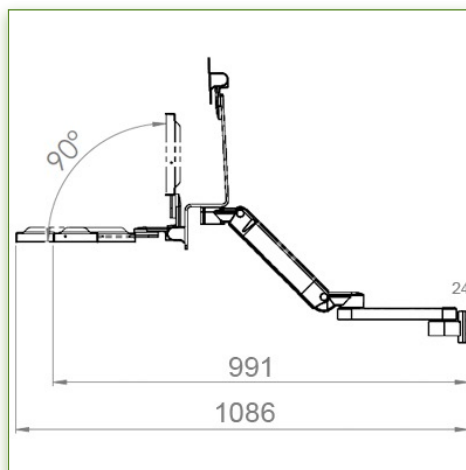
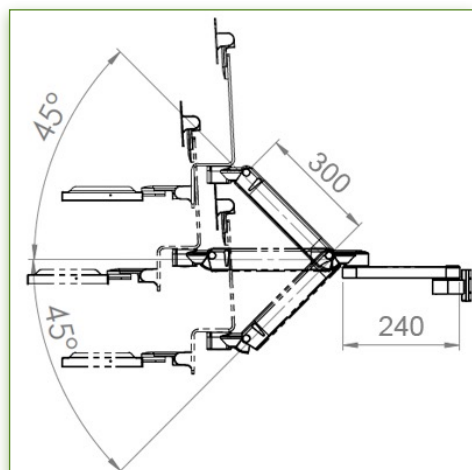
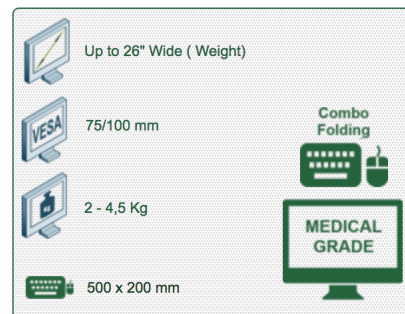

Do not hesitate to contact us if you have any questions about this product.

Warranty: 5 years

000.991.692-1-3

Graphite Grey and White

On Measure

= Depending on the elements

991.692-1-3

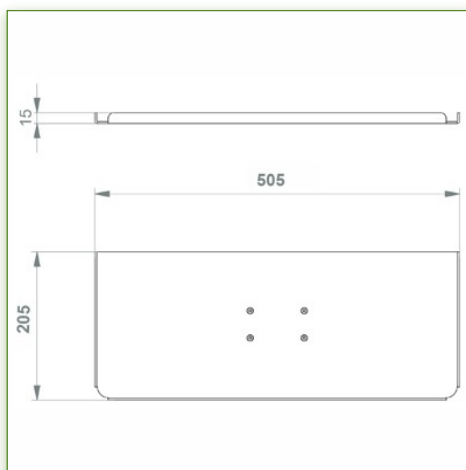
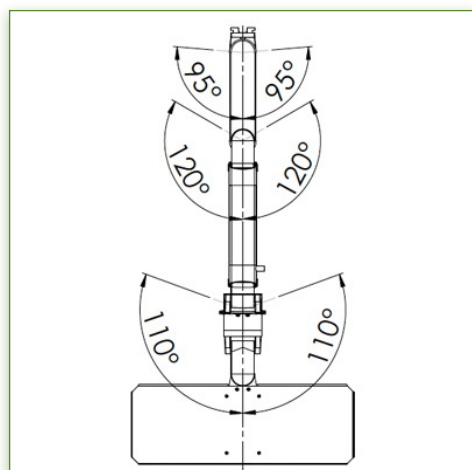

Anti-bacterial properties:

IT medical arms are now designed with Microban antibacterial protection, a revolutionary treatment that guarantees optimal hygiene. IT medical arms integrate Microban and other antibacterial agents into all medical products. It inhibits the growth of bacteria of all types. This is not a surface treatment. It is 100% in the totality of the product. It does not alter the physico-mechanical properties of the medical arm lift system. Simulations over 30 years show that 100% of the antibacterial properties are maintained. All medical articulated arms incorporate Microban. Microban is the world's leading provider of anti-bacterial solutions. It has been successfully applied for more than 35 years in a wide range of products used in the hospital, construction and food industries.

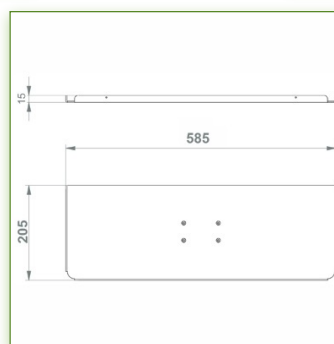
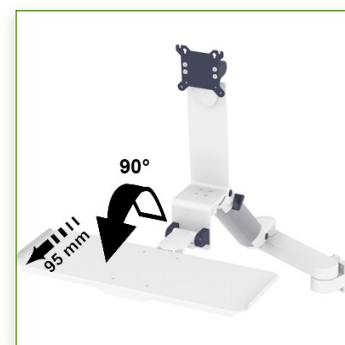

Display Compatibility: 26" Wide (Weight)
Supported Weight: 2- 4,5 Kg
VESA standard: 75 / 100 mm
Keyboard-Mouse holder: 580 x 200 mm

 Up to 26" Wide (Weight)
 75/100 mm
 2 - 4,5 Kg
 580 x 200 mm
 MEDICAL GRADE
 Combo Folding

Do not hesitate to contact us if you have any questions about this product.

Warranty: 5 years

000.991.692-1-4

Graphite Grey and White

On Measure

= Depending on the elements

991.692-1-4

300 + 240 mm height-adjustable Medical Combo Folding Arm for monitor, keyboard and mouse, wall mounting on vertical sliding rail

This 300 + 240 mm Folding Combo Medical Arm with gas spring height adjustment allows the LCD screen to be perfectly fixed, oriented and adjusted and supports the keyboard and mouse. It is coated with an anti-microbial agent offering hygiene and cleaning down to the last detail. Its modern design has been specially designed for healthcare environments.

Technical specifications:

- * Integrated cable channel
- * Equipotential bonding
- * Optional Vertical Wall Slide Rail Mounting available in several lengths (480 mm - 720 mm - 960 mm - 1200 mm).
- * These wall rails can be easily cut to the required size. All cables also pass through the wall rail. (See Options below)
- * This 300 + 240 mm Combo Folding Arm with gas spring simply slides into the wall rail to adjust to the desired height and fixed.
- * It has a safety height adjustment stop button, which allows the arm to remain in the chosen position.
- * The head of this arm complies with the standard for mounting screens: VESA MIS-D 75 mm and 100 mm.
- * Compatible with screens whose weight does not exceed 2 - 4,5 Kg.
- * Touch screen stability. * Screen tilt: 10°.
- * Screen rotation: 110° right, 110° left.
- * Arm rotation: 105° to the right, 105° to the left.
- * Height adjustment: 45° down, 45° up * Total length 991 - 1086 mm
- * Foldable and removable keyboard and mouse holder: 580 x 200 mm
- * Compatible with multimedia terminals (TMM)
- * Color RAL 7024 (Graphite Grey) and White
- * All our medical arms are in conformity: CE, ROHS, Medical Grade, Regulations MDD 93/42 ECC.
- * Warranty: 5 years

Note: This arm can also be installed on one of our medical columns or trolleys.

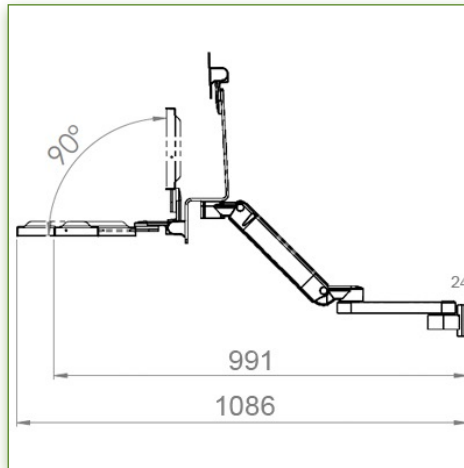
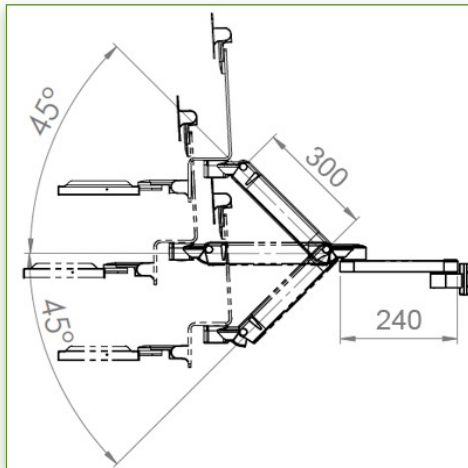

Display Compatibility: 26" Wide (Weight)
Supported Weight: 2- 4,5 Kg
VESA standard: 75 / 100 mm
Keyboard-Mouse holder: 580 x 200 mm

 Up to 26" Wide (Weight)
 75/100 mm
 2 - 4,5 Kg
 580 x 200 mm
MEDICAL GRADE
Combo Folding

Do not hesitate to contact us if you have any questions about this product.

Warranty: 5 years

000.991.692-1-4

Graphite Grey and White

On Measure

= Depending on the elements

991.692-1-4

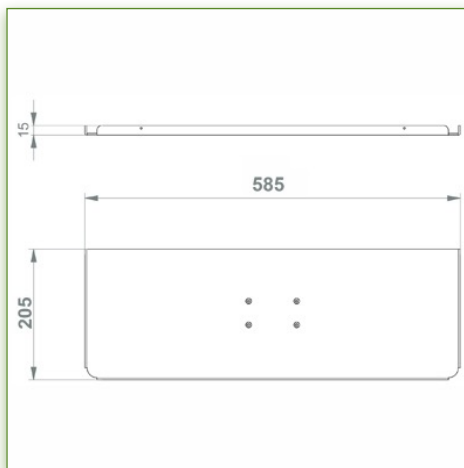
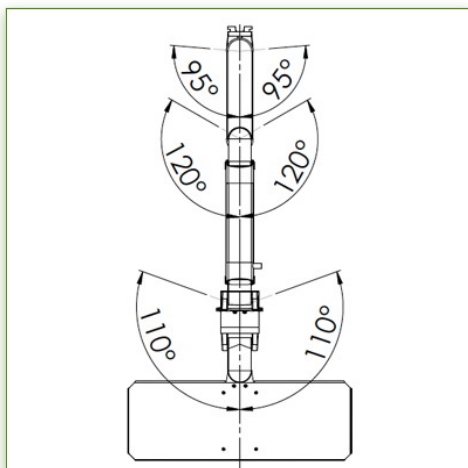

Anti-bacterial properties:

IT medical arms are now designed with Microban antibacterial protection, a revolutionary treatment that guarantees optimal hygiene. IT medical arms integrate Microban and other antibacterial agents into all medical products. It inhibits the growth of bacteria of all types. This is not a surface treatment. It is 100% in the totality of the product. It does not alter the physico-mechanical properties of the medical arm lift system. Simulations over 30 years show that 100% of the antibacterial properties are maintained. All medical articulated arms incorporate Microban. Microban is the world's leading provider of anti-bacterial solutions. It has been successfully applied for more than 35 years in a wide range of products used in the hospital, construction and food industries.

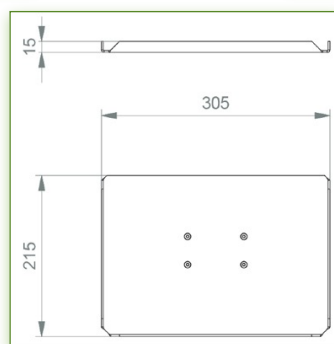
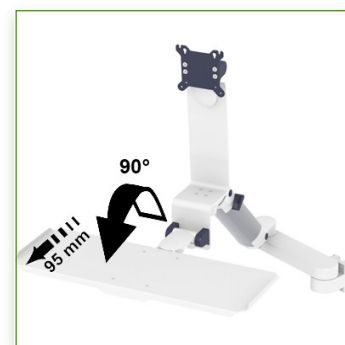

Display Compatibility: 26" Wide (Weight)
Supported Weight: 3- 7 Kg
VESA standard: 75 / 100 mm
Keyboard-Mouse holder: 300 x 210 mm

Up to 26" Wide (Weight)
75/100 mm
3 - 7 Kg
300 x 210 mm

Combo Folding
MEDICAL GRADE

Do not hesitate to contact us if you have any questions about this product.

Warranty: 5 years

000.991.692-2-1

Graphite Grey and White

On Measure

= Depending on the elements

991.692-2-1

300 + 240 mm height-adjustable Medical Combo Folding Arm for monitor, keyboard and mouse, wall mounting on vertical sliding rail

This 300 + 240 mm Folding Combo Medical Arm with gas spring height adjustment allows the LCD screen to be perfectly fixed, oriented and adjusted and supports the keyboard and mouse. It is coated with an anti-microbial agent offering hygiene and cleaning down to the last detail. Its modern design has been specially designed for healthcare environments.

Technical specifications:

- * Integrated cable channel
- * Equipotential bonding
- * Optional Vertical Wall Slide Rail Mounting available in several lengths (480 mm - 720 mm - 960 mm - 1200 mm).
- * These wall rails can be easily cut to the required size. All cables also pass through the wall rail. (See Options below)
- * This 300 + 240 mm Combo Folding Arm with gas spring simply slides into the wall rail to adjust to the desired height and fixed.
- * It has a safety height adjustment stop button, which allows the arm to remain in the chosen position.
- * The head of this arm complies with the standard for mounting screens: VESA MIS-D 75 mm and 100 mm.
- * Compatible with screens whose weight does not exceed 3 - 7 Kg.
- * Touch screen stability. * Screen tilt: 10°.
- * Screen rotation: 110° right, 110° left.
- * Arm rotation: 105° to the right, 105° to the left.
- * Height adjustment: 45° down, 45° up * Total length 991 - 1086 mm
- * Foldable and removable keyboard and mouse holder: 300 x 210 mm
- * Compatible with multimedia terminals (TMM)
- * Color RAL 7024 (Graphite Grey) and White
- * All our medical arms are in conformity: CE, ROHS, Medical Grade, Regulations MDD 93/42 ECC.
- * Warranty: 5 years

Note: This arm can also be installed on one of our medical columns or trolleys.



Display Compatibility: 26" Wide (Weight)
Supported Weight: 3- 7 Kg
VESA standard: 75 / 100 mm
Keyboard-Mouse holder: 300 x 210 mm

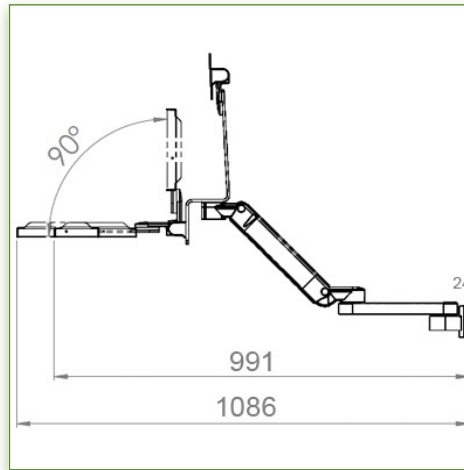
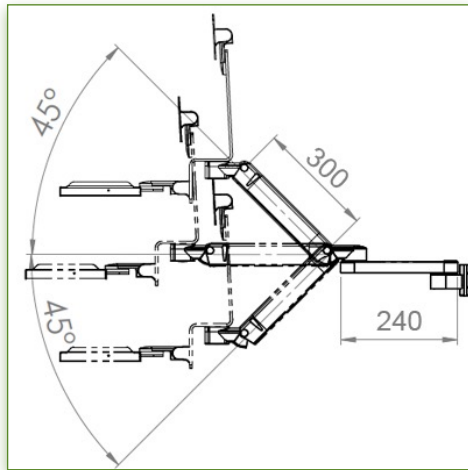
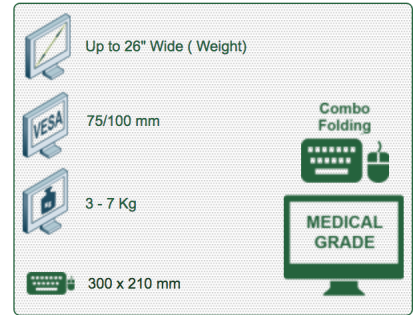

Medical Grade

Do not hesitate to contact us if you have any questions about this product.

- Warranty: 5 years**
- 000.991.692-2-1
- Graphite Grey and White**
- On Measure**
- = Depending on the elements**
- 991.692-2-1**

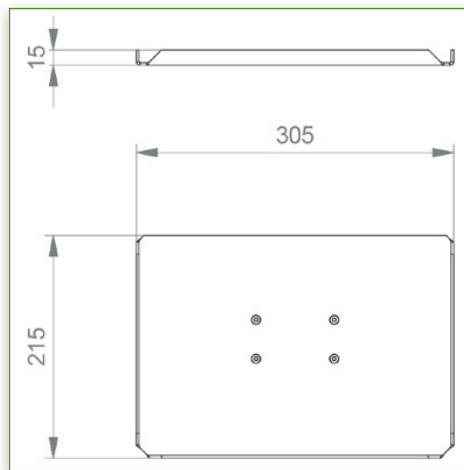
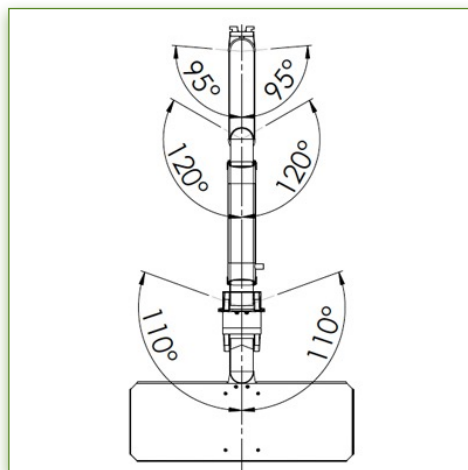

Anti-bacterial properties:

IT medical arms are now designed with Microban antibacterial protection, a revolutionary treatment that guarantees optimal hygiene. IT medical arms integrate Microban and other antibacterial agents into all medical products. It inhibits the growth of bacteria of all types. This is not a surface treatment. It is 100% in the totality of the product. It does not alter the physico-mechanical properties of the medical arm lift system. Simulations over 30 years show that 100% of the antibacterial properties are maintained. All medical articulated arms incorporate Microban. Microban is the world's leading provider of anti-bacterial solutions. It has been successfully applied for more than 35 years in a wide range of products used in the hospital, construction and food industries.

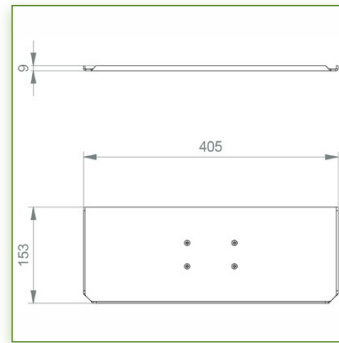
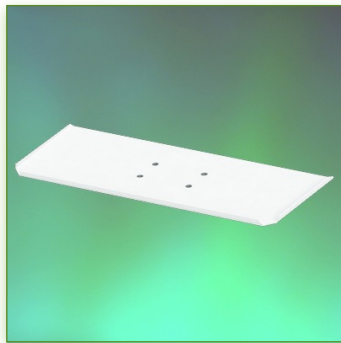
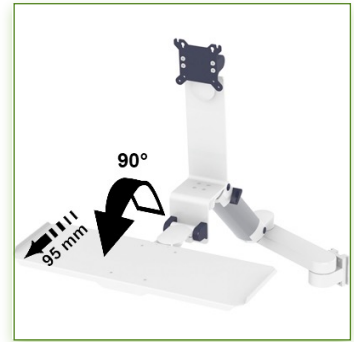

Display Compatibility: 26" Wide (Weight)
Supported Weight: 3- 7 Kg
VESA standard: 75 / 100 mm
Keyboard-Mouse holder: 400 x 150 mm

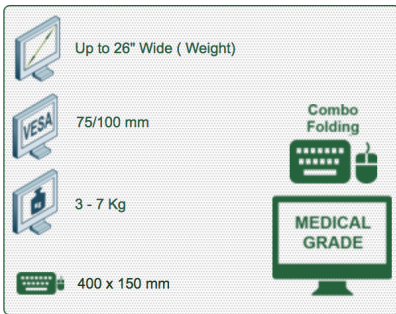

300 + 240 mm height-adjustable Medical Combo Folding Arm for monitor, keyboard and mouse, wall mounting on vertical sliding rail

This 300 + 240 mm Folding Combo Medical Arm with gas spring height adjustment allows the LCD screen to be perfectly fixed, oriented and adjusted and supports the keyboard and mouse. It is coated with an anti-microbial agent offering hygiene and cleaning down to the last detail. Its modern design has been specially designed for healthcare environments.

Technical specifications:

- * Integrated cable channel
- * Equipotential bonding
- * Optional Vertical Wall Slide Rail Mounting available in several lengths (480 mm - 720 mm - 960 mm - 1200 mm).
- * These wall rails can be easily cut to the required size. All cables also pass through the wall rail. (See Options below)
- * This 300 + 240 mm Combo Folding Arm with gas spring simply slides into the wall rail to adjust to the desired height and fixed.
- * It has a safety height adjustment stop button, which allows the arm to remain in the chosen position.
- * The head of this arm complies with the standard for mounting screens: VESA MIS-D 75 mm and 100 mm.
- * Compatible with screens whose weight does not exceed 3 - 7 Kg.
- * Touch screen stability. * Screen tilt: 10°.
- * Screen rotation: 110° right, 110° left.
- * Arm rotation: 105° to the right, 105° to the left.
- * Height adjustment: 45° down, 45° up * Total length 991 - 1086 mm
- * Foldable and removable keyboard and mouse holder: 400 x 150 mm
- * Compatible with multimedia terminals (TMM)
- * Color RAL 7024 (Graphite Grey) and White
- * All our medical arms are in conformity: CE, ROHS, Medical Grade, Regulations MDD 93/42 ECC.
- * Warranty: 5 years

Note: This arm can also be installed on one of our medical columns or trolleys.

Do not hesitate to contact us if you have any questions about this product.

Warranty: 5 years

000.991.692-2-2

Graphite Grey and White

On Measure

= Depending on the elements

991.692-2-2



Display Compatibility: 26" Wide (Weight)
Supported Weight: 3- 7 Kg
VESA standard: 75 / 100 mm
Keyboard-Mouse holder: 400 x 150 mm

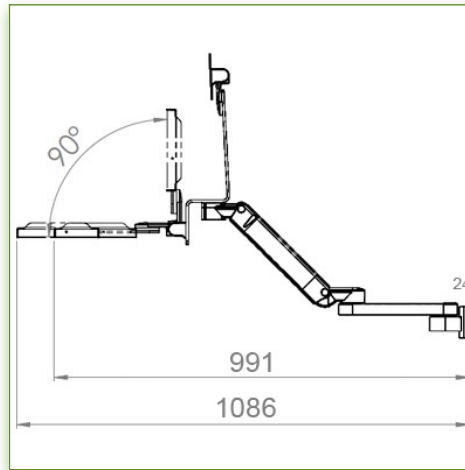
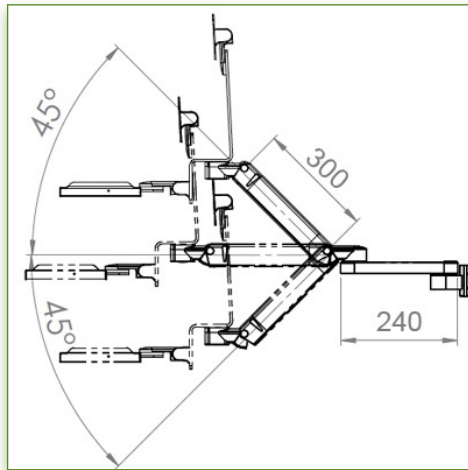
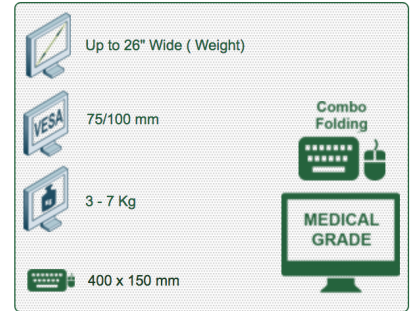

Do not hesitate to contact us if you have any questions about this product.



Warranty: 5 years



000.991.692-2-2



Graphite Grey and White



On Measure



= Depending on the elements



991.692-2-2

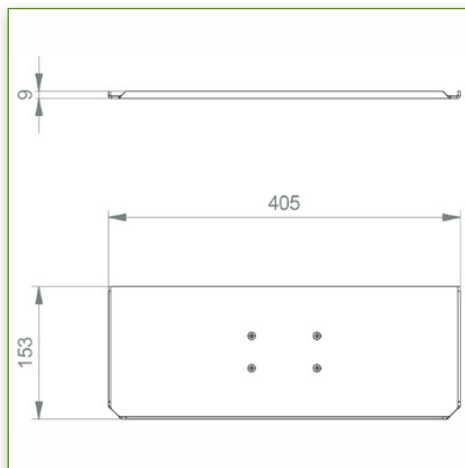
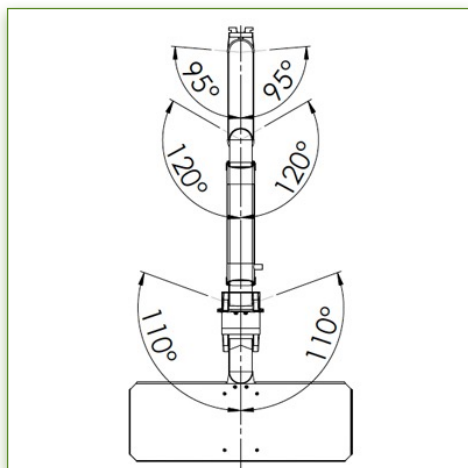

Anti-bacterial properties:

IT medical arms are now designed with Microban antibacterial protection, a revolutionary treatment that guarantees optimal hygiene. IT medical arms integrate Microban and other antibacterial agents into all medical products. It inhibits the growth of bacteria of all types. This is not a surface treatment. It is 100% in the totality of the product. It does not alter the physico-mechanical properties of the medical arm lift system. Simulations over 30 years show that 100% of the antibacterial properties are maintained. All medical articulated arms incorporate Microban. Microban is the world's leading provider of anti-bacterial solutions. It has been successfully applied for more than 35 years in a wide range of products used in the hospital, construction and food industries.

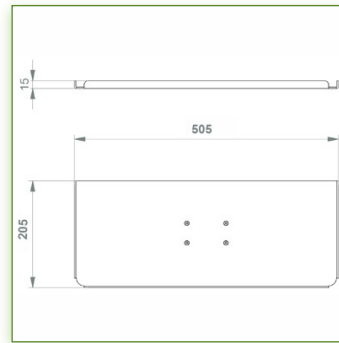
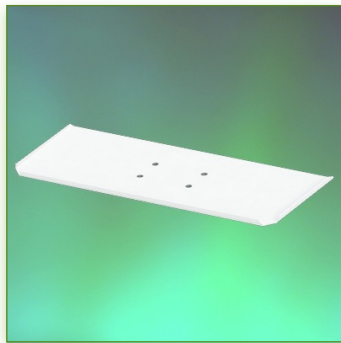
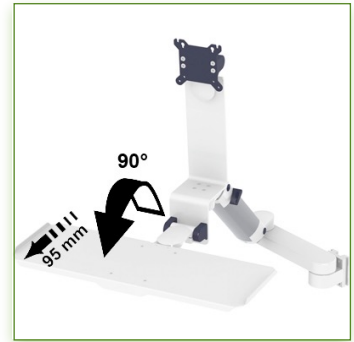

Display Compatibility: 26" Wide (Weight)
Supported Weight: 3- 7 Kg
VESA standard: 75 / 100 mm
Keyboard-Mouse holder: 500 x 200 mm

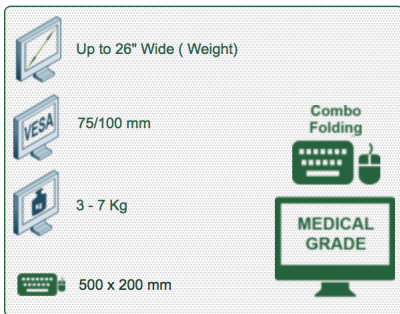

Do not hesitate to contact us if you have any questions about this product.

Warranty: 5 years

000.991.692-2-3

Graphite Grey and White

On Measure

= Depending on the elements

991.692-2-3

300 + 240 mm height-adjustable Medical Combo Folding Arm for monitor, keyboard and mouse, wall mounting on vertical sliding rail

This 300 + 240 mm Folding Combo Medical Arm with gas spring height adjustment allows the LCD screen to be perfectly fixed, oriented and adjusted and supports the keyboard and mouse. It is coated with an anti-microbial agent offering hygiene and cleaning down to the last detail. Its modern design has been specially designed for healthcare environments.

Technical specifications:

- * Integrated cable channel
- * Equipotential bonding
- * Optional Vertical Wall Slide Rail Mounting available in several lengths (480 mm - 720 mm - 960 mm - 1200 mm).
- * These wall rails can be easily cut to the required size. All cables also pass through the wall rail. (See Options below)
- * This 300 + 240 mm Combo Folding Arm with gas spring simply slides into the wall rail to adjust to the desired height and fixed.
- * It has a safety height adjustment stop button, which allows the arm to remain in the chosen position.
- * The head of this arm complies with the standard for mounting screens: VESA MIS-D 75 mm and 100 mm.
- * Compatible with screens whose weight does not exceed 3 - 7 Kg.
- * Touch screen stability. * Screen tilt: 10°.
- * Screen rotation: 110° right, 110° left.
- * Arm rotation: 105° to the right, 105° to the left.
- * Height adjustment: 45° down, 45° up * Total length 991 - 1086 mm
- * Foldable and removable keyboard and mouse holder: 500 x 200 mm
- * Compatible with multimedia terminals (TMM)
- * Color RAL 7024 (Graphite Grey) and White
- * All our medical arms are in conformity: CE, ROHS, Medical Grade, Regulations MDD 93/42 ECC.
- * Warranty: 5 years

Note: This arm can also be installed on one of our medical columns or trolleys.



Display Compatibility: 26" Wide (Weight)
Supported Weight: 3- 7 Kg
VESA standard: 75 / 100 mm
Keyboard-Mouse holder: 500 x 200 mm

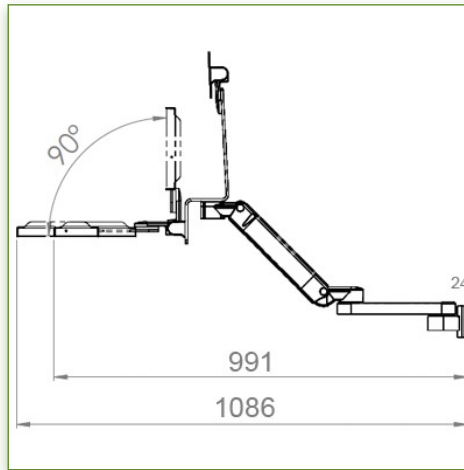
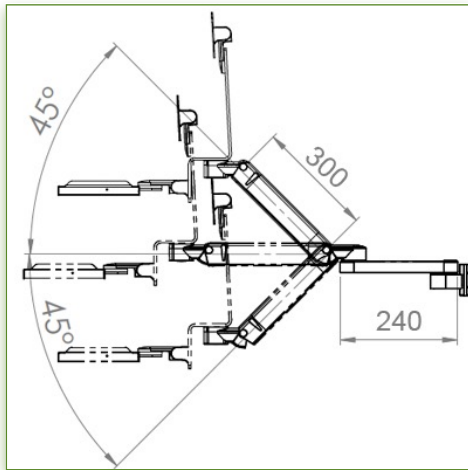
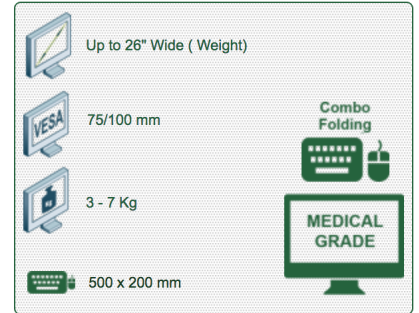

Do not hesitate to contact us if you have any questions about this product.



Warranty: 5 years



000.991.692-2-3



Graphite Grey and White



On Measure



= Depending on the elements



991.692-2-3

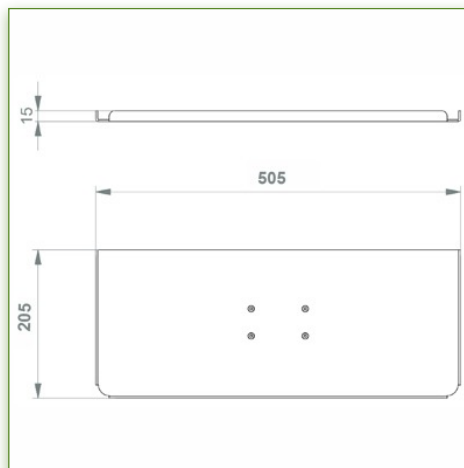
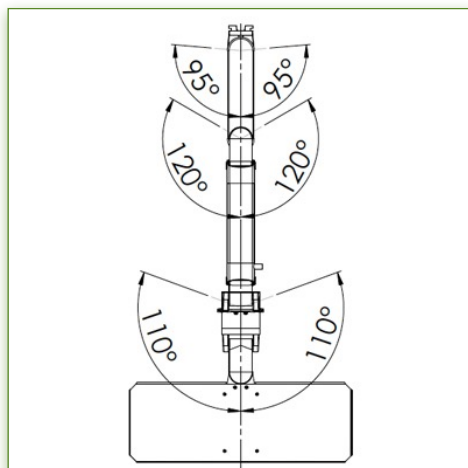

Anti-bacterial properties:

IT medical arms are now designed with Microban antibacterial protection, a revolutionary treatment that guarantees optimal hygiene. IT medical arms integrate Microban and other antibacterial agents into all medical products. It inhibits the growth of bacteria of all types. This is not a surface treatment. It is 100% in the totality of the product. It does not alter the physico-mechanical properties of the medical arm lift system. Simulations over 30 years show that 100% of the antibacterial properties are maintained. All medical articulated arms incorporate Microban. Microban is the world's leading provider of anti-bacterial solutions. It has been successfully applied for more than 35 years in a wide range of products used in the hospital, construction and food industries.

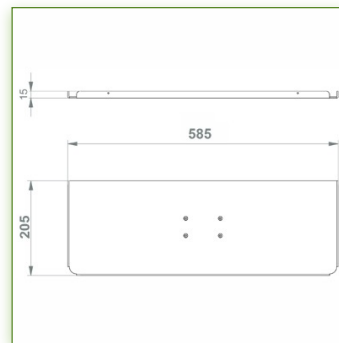
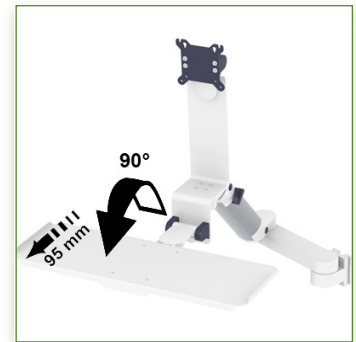

Display Compatibility: 26" Wide (Weight)
Supported Weight: 3- 7 Kg
VESA standard: 75 / 100 mm
Keyboard-Mouse holder: 580 x 200 mm

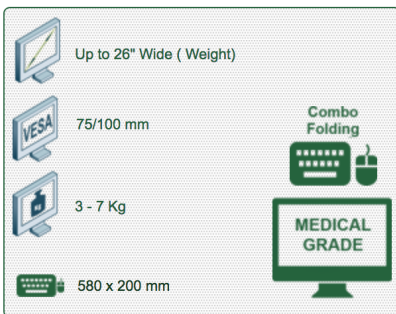

Do not hesitate to contact us if you have any questions about this product.

Warranty: 5 years

000.991.692-2-4

Graphite Grey and White

On Measure

= Depending on the elements

991.692-2-4

300 + 240 mm height-adjustable Medical Combo Folding Arm for monitor, keyboard and mouse, wall mounting on vertical sliding rail

This 300 + 240 mm Folding Combo Medical Arm with gas spring height adjustment allows the LCD screen to be perfectly fixed, oriented and adjusted and supports the keyboard and mouse. It is coated with an anti-microbial agent offering hygiene and cleaning down to the last detail. Its modern design has been specially designed for healthcare environments.

Technical specifications:

- * Integrated cable channel
- * Equipotential bonding
- * Optional Vertical Wall Slide Rail Mounting available in several lengths (480 mm - 720 mm - 960 mm - 1200 mm).
- * These wall rails can be easily cut to the required size. All cables also pass through the wall rail. (See Options below)
- * This 300 + 240 mm Combo Folding Arm with gas spring simply slides into the wall rail to adjust to the desired height and fixed.
- * It has a safety height adjustment stop button, which allows the arm to remain in the chosen position.
- * The head of this arm complies with the standard for mounting screens: VESA MIS-D 75 mm and 100 mm.
- * Compatible with screens whose weight does not exceed 3 - 7 Kg.
- * Touch screen stability. * Screen tilt: 10°.
- * Screen rotation: 110° right, 110° left.
- * Arm rotation: 105° to the right, 105° to the left.
- * Height adjustment: 45° down, 45° up * Total length 991 - 1086 mm
- * Foldable and removable keyboard and mouse holder: 580 x 200 mm
- * Compatible with multimedia terminals (TMM)
- * Color RAL 7024 (Graphite Grey) and White
- * All our medical arms are in conformity: CE, ROHS, Medical Grade, Regulations MDD 93/42 ECC.
- * Warranty: 5 years

Note: This arm can also be installed on one of our medical columns or trolleys.

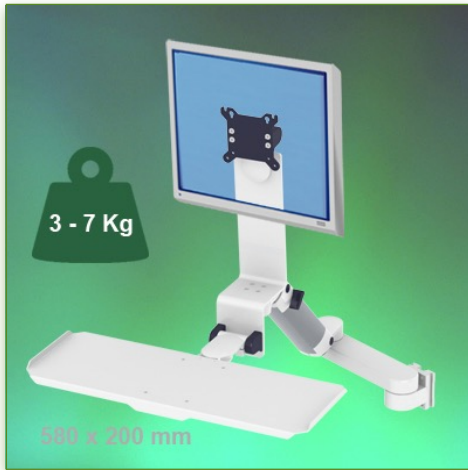

Display Compatibility: 26" Wide (Weight)
Supported Weight: 3- 7 Kg
VESA standard: 75 / 100 mm
Keyboard-Mouse holder: 580 x 200 mm

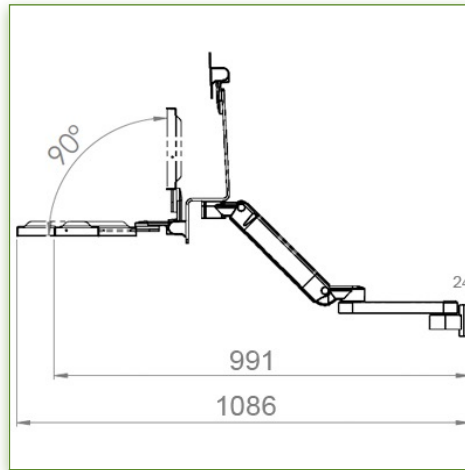
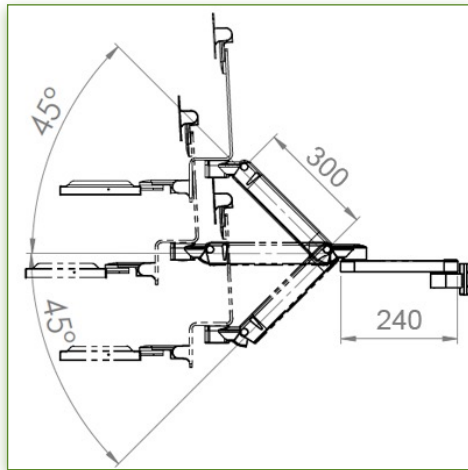
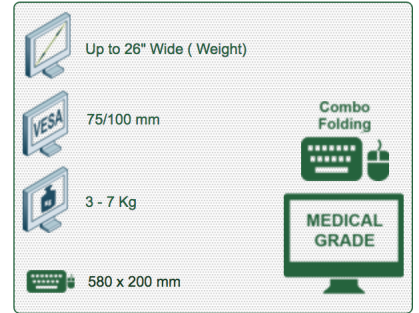

Do not hesitate to contact us if you have any questions about this product.



Warranty: 5 years



000.991.692-2-4



Graphite Grey and White



On Measure



= Depending on the elements



991.692-2-4

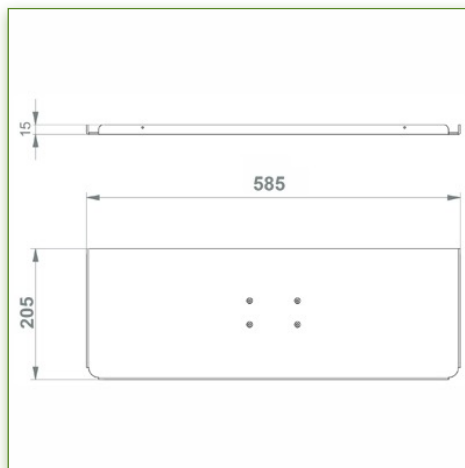
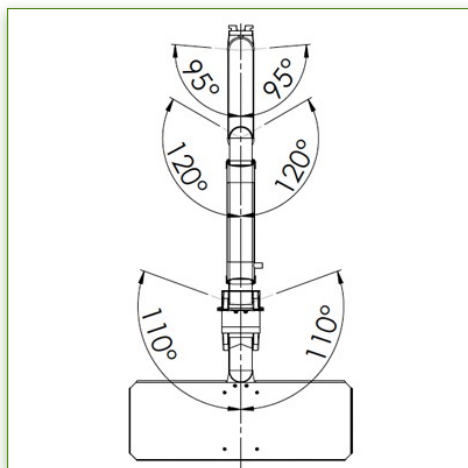

Anti-bacterial properties:

IT medical arms are now designed with Microban antibacterial protection, a revolutionary treatment that guarantees optimal hygiene. IT medical arms integrate Microban and other antibacterial agents into all medical products. It inhibits the growth of bacteria of all types. This is not a surface treatment. It is 100% in the totality of the product. It does not alter the physico-mechanical properties of the medical arm lift system. Simulations over 30 years show that 100% of the antibacterial properties are maintained. All medical articulated arms incorporate Microban. Microban is the world's leading provider of anti-bacterial solutions. It has been successfully applied for more than 35 years in a wide range of products used in the hospital, construction and food industries.

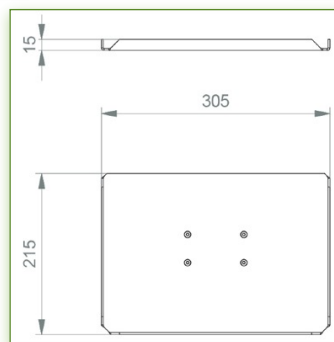
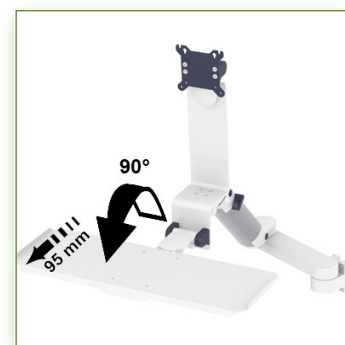

Display Compatibility: 26" Wide (Weight)
Supported Weight: 4- 9,5 Kg
VESA standard: 75 / 100 mm
Keyboard-Mouse holder: 300 x 210 mm

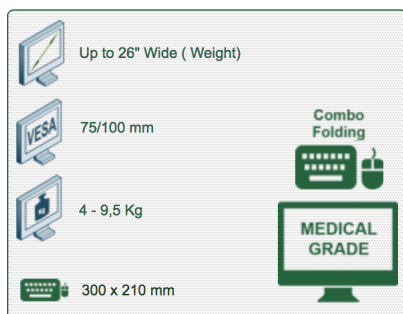

Do not hesitate to contact us if you have any questions about this product.

Warranty: 5 years

000.991.692-3-1

Graphite Grey and White

On Measure

= Depending on the elements

991.692-3-1

300 + 240 mm height-adjustable Medical Combo Folding Arm for monitor, keyboard and mouse, wall mounting on vertical sliding rail

This 300 + 240 mm Folding Combo Medical Arm with gas spring height adjustment allows the LCD screen to be perfectly fixed, oriented and adjusted and supports the keyboard and mouse. It is coated with an anti-microbial agent offering hygiene and cleaning down to the last detail. Its modern design has been specially designed for healthcare environments.

Technical specifications:

- * Integrated cable channel
- * Equipotential bonding
- * Optional Vertical Wall Slide Rail Mounting available in several lengths (480 mm - 720 mm - 960 mm - 1200 mm).
- * These wall rails can be easily cut to the required size. All cables also pass through the wall rail. (See Options below)
- * This 300 + 240 mm Combo Folding Arm with gas spring simply slides into the wall rail to adjust to the desired height and fixed.
- * It has a safety height adjustment stop button, which allows the arm to remain in the chosen position.
- * The head of this arm complies with the standard for mounting screens: VESA MIS-D 75 mm and 100 mm.
- * Compatible with screens whose weight does not exceed 4 - 9,5 Kg.
- * Touch screen stability. * Screen tilt: 10°.
- * Screen rotation: 110° right, 110° left.
- * Arm rotation: 105° to the right, 105° to the left.
- * Height adjustment: 45° down, 45° up * Total length 991 - 1086 mm
- * Foldable and removable keyboard and mouse holder: 300 x 210 mm
- * Compatible with multimedia terminals (TMM)
- * Color RAL 7024 (Graphite Grey) and White
- * All our medical arms are in conformity: CE, ROHS, Medical Grade, Regulations MDD 93/42 ECC.
- * Warranty: 5 years

Note: This arm can also be installed on one of our medical columns or trolleys.



Display Compatibility: 26" Wide (Weight)
Supported Weight: 4- 9,5 Kg
VESA standard: 75 / 100 mm
Keyboard-Mouse holder: 300 x 210 mm

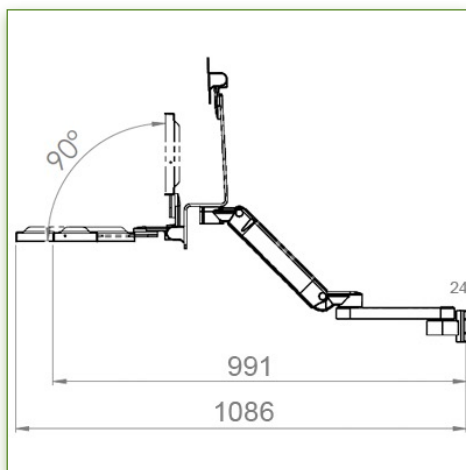
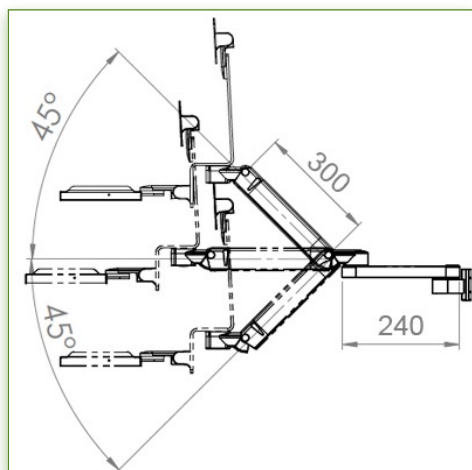
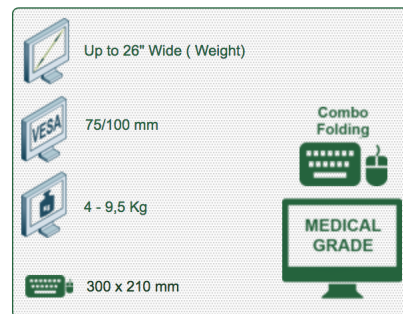

Do not hesitate to contact us if you have any questions about this product.

Warranty: 5 years

000.991.692-3-1

Graphite Grey and White

On Measure

= Depending on the elements

991.692-3-1

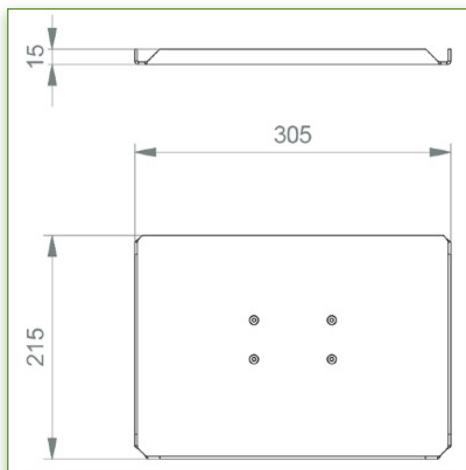
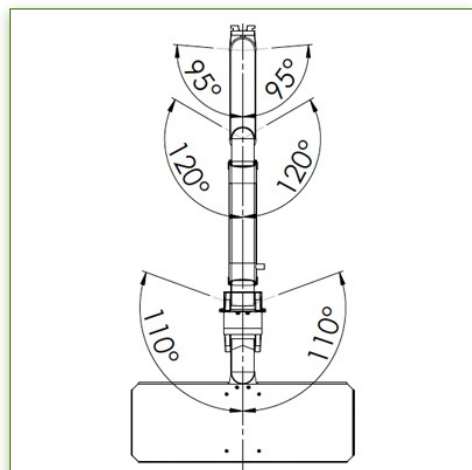

Anti-bacterial properties:

IT medical arms are now designed with Microban antibacterial protection, a revolutionary treatment that guarantees optimal hygiene. IT medical arms integrate Microban and other antibacterial agents into all medical products. It inhibits the growth of bacteria of all types. This is not a surface treatment.

It is 100% in the totality of the product. It does not alter the physico-mechanical properties of the medical arm lift system. Simulations over 30 years show that 100% of the antibacterial properties are maintained.

All medical articulated arms incorporate Microban. Microban is the world's leading provider of anti-bacterial solutions. It has been successfully applied for more than 35 years in a wide range of products used in the hospital, construction and food industries.

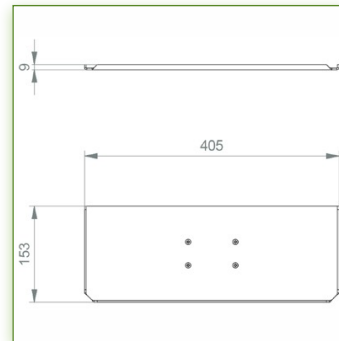
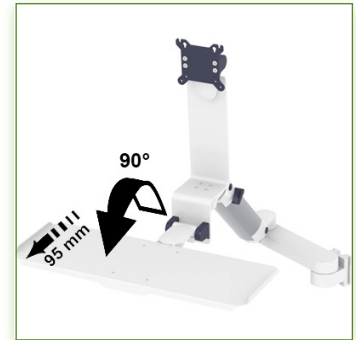

Display Compatibility: 26" Wide (Weight)
Supported Weight: 4- 9,5 Kg
VESA standard: 75 / 100 mm
Keyboard-Mouse holder: 400 x 150 mm

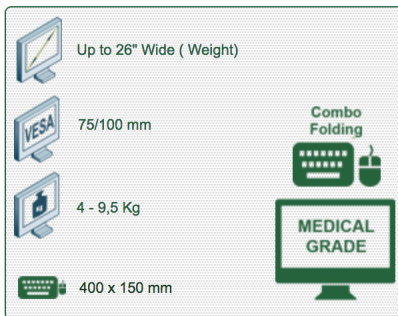

300 + 240 mm height-adjustable Medical Combo Folding Arm for monitor, keyboard and mouse, wall mounting on vertical sliding rail

This 300 + 240 mm Folding Combo Medical Arm with gas spring height adjustment allows the LCD screen to be perfectly fixed, oriented and adjusted and supports the keyboard and mouse. It is coated with an anti-microbial agent offering hygiene and cleaning down to the last detail. Its modern design has been specially designed for healthcare environments.

Technical specifications:

- * Integrated cable channel
- * Equipotential bonding
- * Optional Vertical Wall Slide Rail Mounting available in several lengths (480 mm - 720 mm - 960 mm - 1200 mm).
- * These wall rails can be easily cut to the required size. All cables also pass through the wall rail. (See Options below)
- * This 300 + 240 mm Combo Folding Arm with gas spring simply slides into the wall rail to adjust to the desired height and fixed.
- * It has a safety height adjustment stop button, which allows the arm to remain in the chosen position.
- * The head of this arm complies with the standard for mounting screens: VESA MIS-D 75 mm and 100 mm.
- * Compatible with screens whose weight does not exceed 4 - 9,5 Kg.
- * Touch screen stability. * Screen tilt: 10°.
- * Screen rotation: 110° right, 110° left.
- * Arm rotation: 105° to the right, 105° to the left.
- * Height adjustment: 45° down, 45° up * Total length 991 - 1086 mm
- * Foldable and removable keyboard and mouse holder: 400 x 150 mm
- * Compatible with multimedia terminals (TMM)
- * Color RAL 7024 (Graphite Grey) and White
- * All our medical arms are in conformity: CE, ROHS, Medical Grade, Regulations MDD 93/42 ECC.
- * Warranty: 5 years

Note: This arm can also be installed on one of our medical columns or trolleys.

Do not hesitate to contact us if you have any questions about this product.

Warranty: 5 years

000.991.692-3-2

Graphite Grey and White

On Measure

= Depending on the elements

991.692-3-2

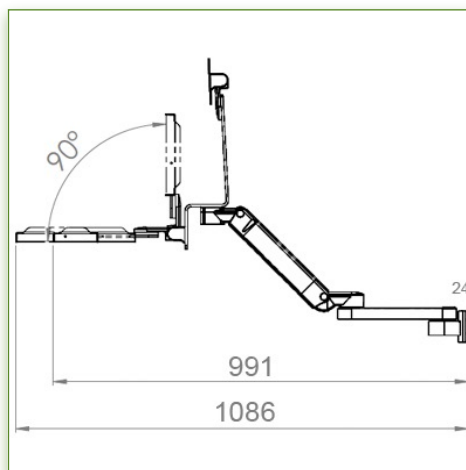
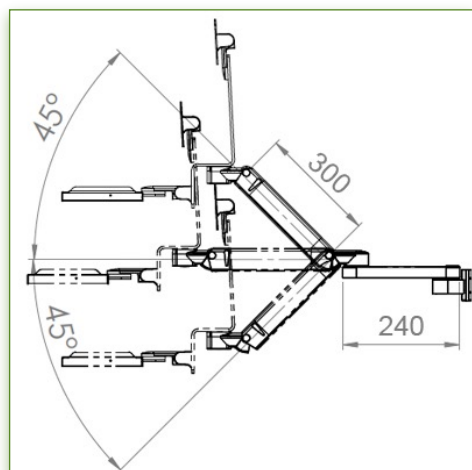

Display Compatibility: 26" Wide (Weight)
Supported Weight: 4- 9,5 Kg
VESA standard: 75 / 100 mm
Keyboard-Mouse holder: 400 x 150 mm

 Up to 26" Wide (Weight)
 75/100 mm
 4 - 9,5 Kg
 400 x 150 mm
MEDICAL GRADE
Combo Folding

Do not hesitate to contact us if you have any questions about this product.

Warranty: 5 years

000.991.692-3-2

Graphite Grey and White

On Measure

= **Depending on the elements**

991.692-3-2

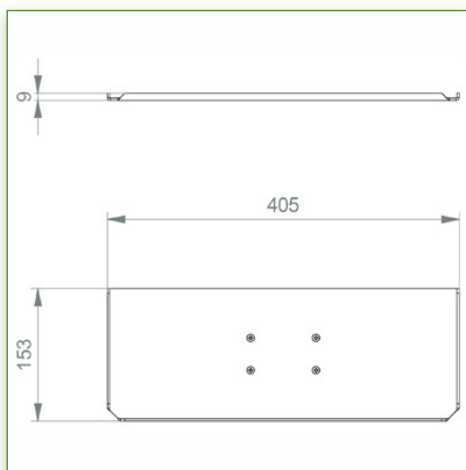
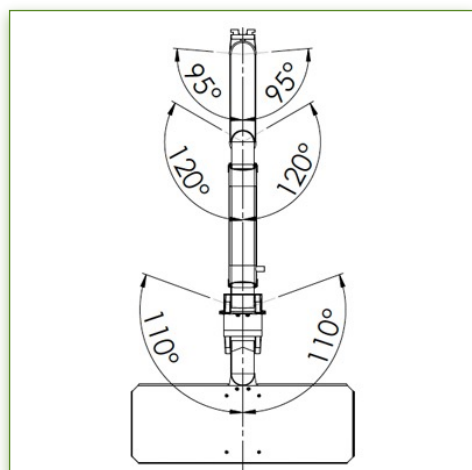

Anti-bacterial properties:

IT medical arms are now designed with Microban antibacterial protection, a revolutionary treatment that guarantees optimal hygiene. IT medical arms integrate Microban and other antibacterial agents into all medical products. It inhibits the growth of bacteria of all types. This is not a surface treatment. It is 100% in the totality of the product. It does not alter the physico-mechanical properties of the medical arm lift system. Simulations over 30 years show that 100% of the antibacterial properties are maintained. All medical articulated arms incorporate Microban. Microban is the world's leading provider of anti-bacterial solutions. It has been successfully applied for more than 35 years in a wide range of products used in the hospital, construction and food industries.

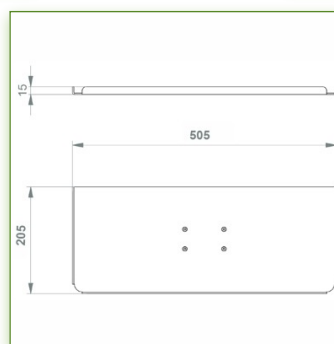
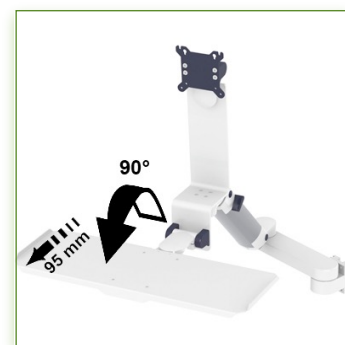

Display Compatibility: 26" Wide (Weight)
Supported Weight: 4- 9,5 Kg
VESA standard: 75 / 100 mm
Keyboard-Mouse holder: 500 x 200 mm

Up to 26" Wide (Weight)

75/100 mm

4 - 9,5 Kg

500 x 200 mm

Combo Folding

MEDICAL GRADE

Do not hesitate to contact us if you have any questions about this product.

Warranty: 5 years

000.991.692-3-3

Graphite Grey and White

On Measure

= Depending on the elements

991.692-3-3

300 + 240 mm height-adjustable Medical Combo Folding Arm for monitor, keyboard and mouse, wall mounting on vertical sliding rail

This 300 + 240 mm Folding Combo Medical Arm with gas spring height adjustment allows the LCD screen to be perfectly fixed, oriented and adjusted and supports the keyboard and mouse. It is coated with an anti-microbial agent offering hygiene and cleaning down to the last detail. Its modern design has been specially designed for healthcare environments.

Technical specifications:

- * Integrated cable channel
- * Equipotential bonding
- * Optional Vertical Wall Slide Rail Mounting available in several lengths (480 mm - 720 mm - 960 mm - 1200 mm).
- * These wall rails can be easily cut to the required size. All cables also pass through the wall rail. (See Options below)
- * This 300 + 240 mm Combo Folding Arm with gas spring simply slides into the wall rail to adjust to the desired height and fixed.
- * It has a safety height adjustment stop button, which allows the arm to remain in the chosen position.
- * The head of this arm complies with the standard for mounting screens: VESA MIS-D 75 mm and 100 mm.
- * Compatible with screens whose weight does not exceed 4 - 9,5 Kg.
- * Touch screen stability. * Screen tilt: 10°.
- * Screen rotation: 110° right, 110° left.
- * Arm rotation: 105° to the right, 105° to the left.
- * Height adjustment: 45° down, 45° up * Total length 991 - 1086 mm
- * Foldable and removable keyboard and mouse holder: 500 x 200 mm
- * Compatible with multimedia terminals (TMM)
- * Color RAL 7024 (Graphite Grey) and White
- * All our medical arms are in conformity: CE, ROHS, Medical Grade, Regulations MDD 93/42 ECC.
- * Warranty: 5 years

Note: This arm can also be installed on one of our medical columns or trolleys.



Display Compatibility: 26" Wide (Weight)
Supported Weight: 4- 9,5 Kg
VESA standard: 75 / 100 mm
Keyboard-Mouse holder: 500 x 200 mm

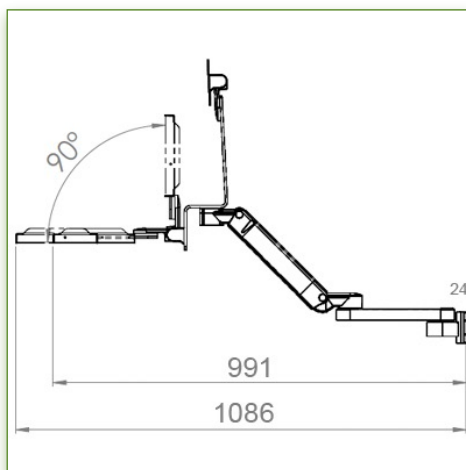
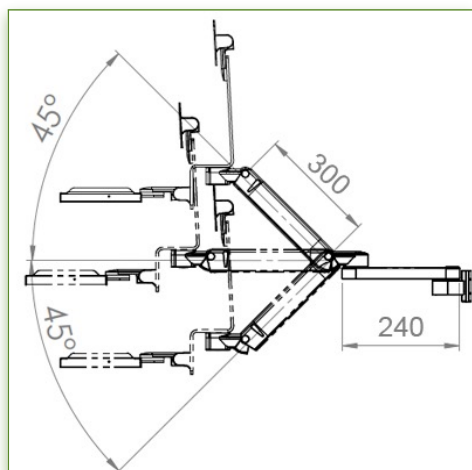
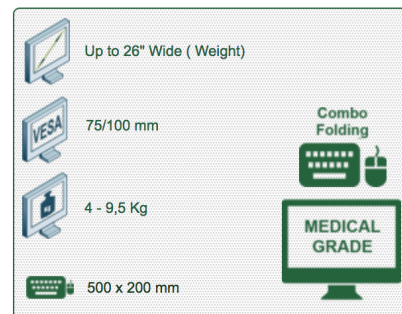

Medical Grade

Do not hesitate to contact us if you have any questions about this product.

Warranty: 5 years

000.991.692-3-3

Graphite Grey and White

On Measure

= Depending on the elements

991.692-3-3

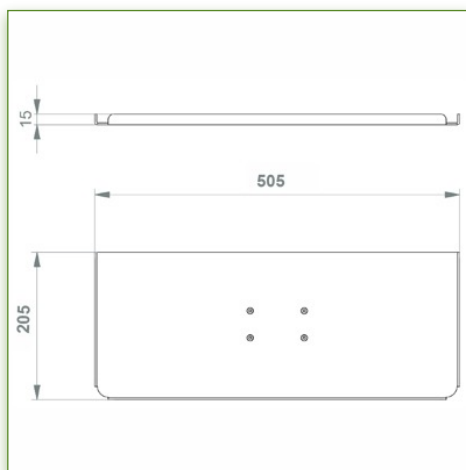
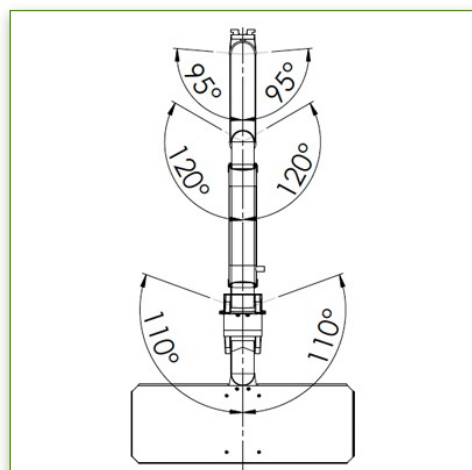

Anti-bacterial properties:

IT medical arms are now designed with Microban antibacterial protection, a revolutionary treatment that guarantees optimal hygiene. IT medical arms integrate Microban and other antibacterial agents into all medical products. It inhibits the growth of bacteria of all types. This is not a surface treatment. It is 100% in the totality of the product. It does not alter the physico-mechanical properties of the medical arm lift system. Simulations over 30 years show that 100% of the antibacterial properties are maintained. All medical articulated arms incorporate Microban. Microban is the world's leading provider of anti-bacterial solutions. It has been successfully applied for more than 35 years in a wide range of products used in the hospital, construction and food industries.

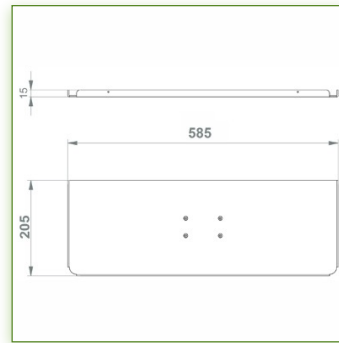
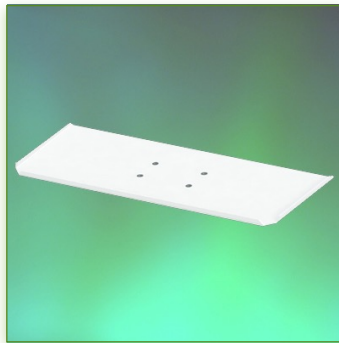
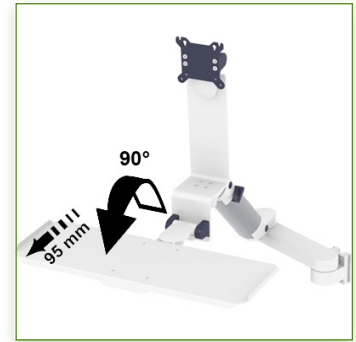
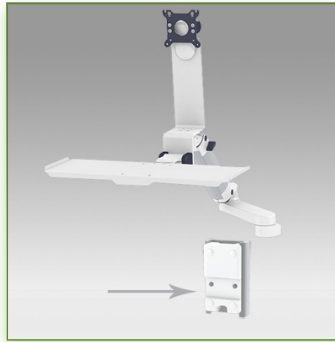

Display Compatibility: 26" Wide (Weight)
Supported Weight: 4- 9,5 Kg
VESA standard: 75 / 100 mm
Keyboard-Mouse holder: 580 x 200 mm

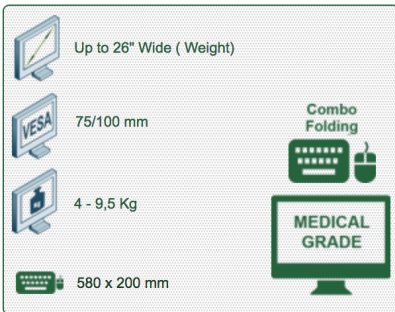

300 + 240 mm height-adjustable Medical Combo Folding Arm for monitor, keyboard and mouse, wall mounting on vertical sliding rail

This 300 + 240 mm Folding Combo Medical Arm with gas spring height adjustment allows the LCD screen to be perfectly fixed, oriented and adjusted and supports the keyboard and mouse. It is coated with an anti-microbial agent offering hygiene and cleaning down to the last detail. Its modern design has been specially designed for healthcare environments.

Technical specifications:

- * Integrated cable channel
- * Equipotential bonding
- * Optional Vertical Wall Slide Rail Mounting available in several lengths (480 mm - 720 mm - 960 mm - 1200 mm).
- * These wall rails can be easily cut to the required size. All cables also pass through the wall rail. (See Options below)
- * This 300 + 240 mm Combo Folding Arm with gas spring simply slides into the wall rail to adjust to the desired height and fixed.
- * It has a safety height adjustment stop button, which allows the arm to remain in the chosen position.
- * The head of this arm complies with the standard for mounting screens: VESA MIS-D 75 mm and 100 mm.
- * Compatible with screens whose weight does not exceed 4 - 9,5 Kg.
- * Touch screen stability. * Screen tilt: 10°.
- * Screen rotation: 110° right, 110° left.
- * Arm rotation: 105° to the right, 105° to the left.
- * Height adjustment: 45° down, 45° up * Total length 991 - 1086 mm
- * Foldable and removable keyboard and mouse holder: 580 x 200 mm
- * Compatible with multimedia terminals (TMM)
- * Color RAL 7024 (Graphite Grey) and White
- * All our medical arms are in conformity: CE, ROHS, Medical Grade, Regulations MDD 93/42 ECC.
- * Warranty: 5 years

Note: This arm can also be installed on one of our medical columns or trolleys.

Do not hesitate to contact us if you have any questions about this product.

Warranty: 5 years

000.991.692-3-4

Graphite Grey and White

On Measure

= Depending on the elements

991.692-3-4



Display Compatibility: 26" Wide (Weight)
Supported Weight: 4- 9,5 Kg
VESA standard: 75 / 100 mm
Keyboard-Mouse holder: 580 x 200 mm

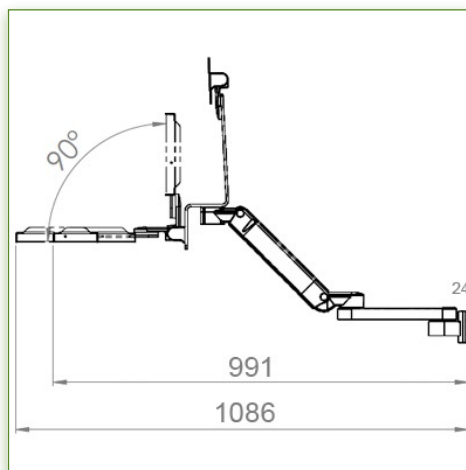
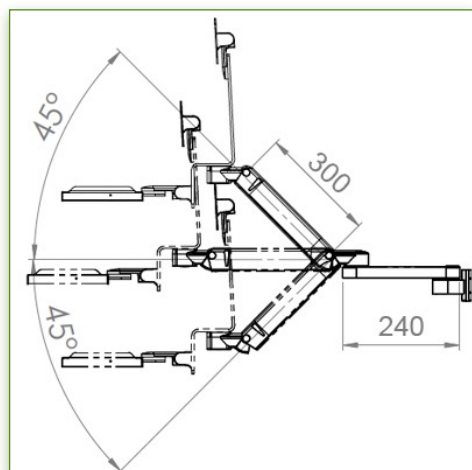
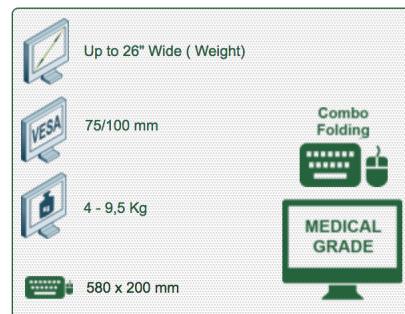

Medical Grade

Do not hesitate to contact us if you have any questions about this product.

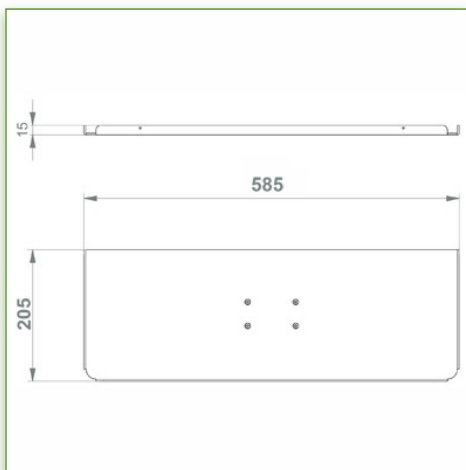
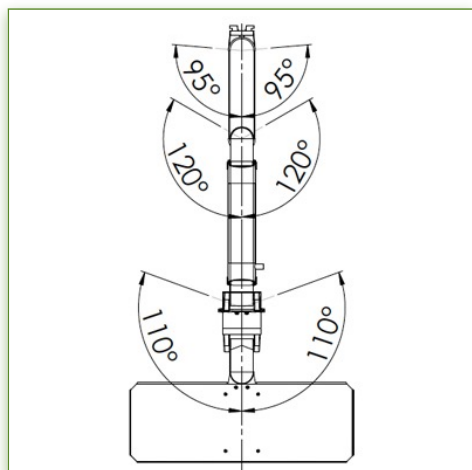

- Warranty: 5 years**
- 000.991.692-3-4**
- Graphite Grey and White**
- On Measure**
- = Depending on the elements**
- 991.692-3-4**

Anti-bacterial properties:

IT medical arms are now designed with Microban antibacterial protection, a revolutionary treatment that guarantees optimal hygiene. IT medical arms integrate Microban and other antibacterial agents into all medical products. It inhibits the growth of bacteria of all types. This is not a surface treatment. It is 100% in the totality of the product. It does not alter the physico-mechanical properties of the medical arm lift system. Simulations over 30 years show that 100% of the antibacterial properties are maintained. All medical articulated arms incorporate Microban. Microban is the world's leading provider of anti-bacterial solutions. It has been successfully applied for more than 35 years in a wide range of products used in the hospital, construction and food industries.

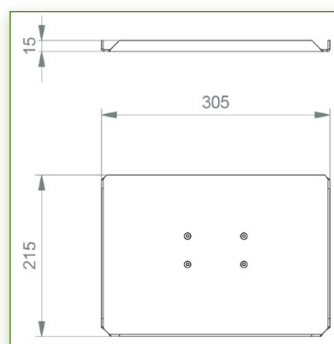
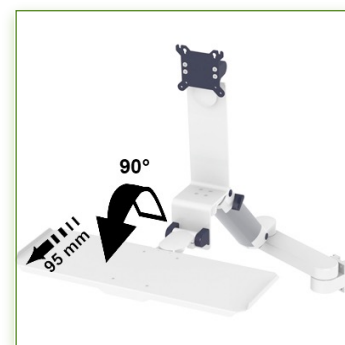

Display Compatibility: 26" Wide (Weight)
Supported Weight: 10- 11,5 Kg
VESA standard: 75 / 100 mm
Keyboard-Mouse holder: 300 x 210 mm

 Up to 26" Wide (Weight)
 75/100 mm
 10 - 11,5 Kg
 300 x 210 mm
 MEDICAL GRADE
 Combo Folding

Do not hesitate to contact us if you have any questions about this product.

Warranty: 5 years

000.991.692-4-1

Graphite Grey and White

On Measure

= Depending on the elements

991.692-4-1

300 + 240 mm height-adjustable Medical Combo Folding Arm for monitor, keyboard and mouse, wall mounting on vertical sliding rail

This 300 + 240 mm Folding Combo Medical Arm with gas spring height adjustment allows the LCD screen to be perfectly fixed, oriented and adjusted and supports the keyboard and mouse. It is coated with an anti-microbial agent offering hygiene and cleaning down to the last detail. Its modern design has been specially designed for healthcare environments.

Technical specifications:

- * Integrated cable channel
- * Equipotential bonding
- * Optional Vertical Wall Slide Rail Mounting available in several lengths (480 mm - 720 mm - 960 mm - 1200 mm).
- * These wall rails can be easily cut to the required size. All cables also pass through the wall rail. (See Options below)
- * This 300 + 240 mm Combo Folding Arm with gas spring simply slides into the wall rail to adjust to the desired height and fixed.
- * It has a safety height adjustment stop button, which allows the arm to remain in the chosen position.
- * The head of this arm complies with the standard for mounting screens: VESA MIS-D 75 mm and 100 mm.
- * Compatible with screens whose weight does not exceed 10 - 11,5 Kg.
- * Touch screen stability. * Screen tilt: 10°.
- * Screen rotation: 110° right, 110° left.
- * Arm rotation: 105° to the right, 105° to the left.
- * Height adjustment: 45° down, 45° up * Total length 991 - 1086 mm
- * Foldable and removable keyboard and mouse holder: 580 x 200 mm
- * Compatible with multimedia terminals (TMM)
- * Color RAL 7024 (Graphite Grey) and White
- * All our medical arms are in conformity: CE, ROHS, Medical Grade, Regulations MDD 93/42 ECC.
- * Warranty: 5 years

Note: This arm can also be installed on one of our medical columns or trolleys.



Display Compatibility: 26" Wide (Weight)
Supported Weight: 10- 11,5 Kg
VESA standard: 75 / 100 mm
Keyboard-Mouse holder: 300 x 210 mm

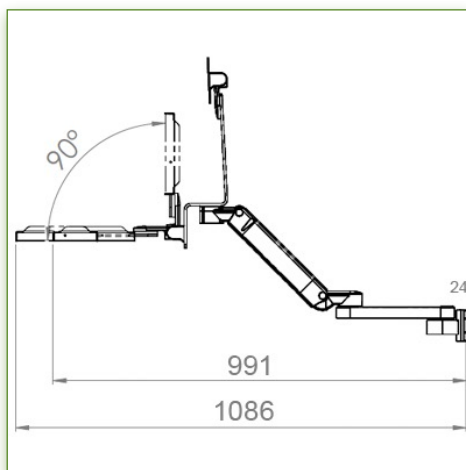
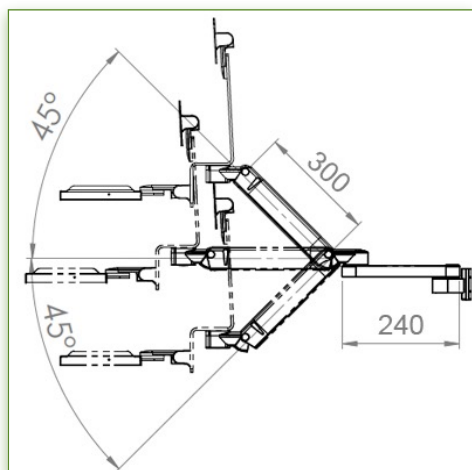
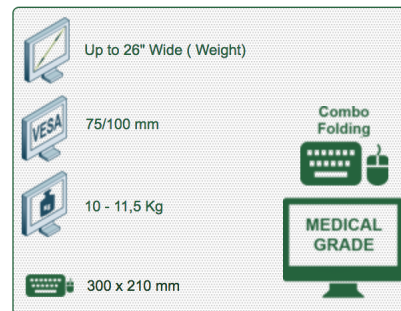

Do not hesitate to contact us if you have any questions about this product.

Warranty: 5 years

000.991.692-4-1

Graphite Grey and White

On Measure

= Depending on the elements

991.692-4-1

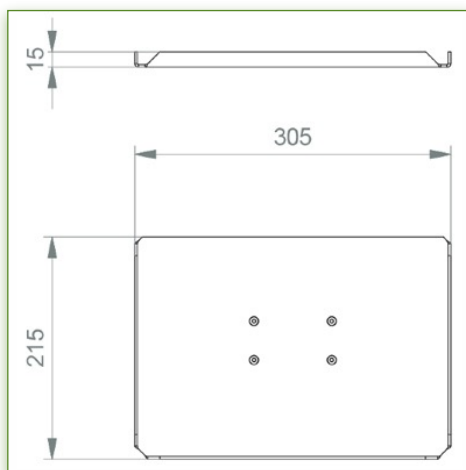
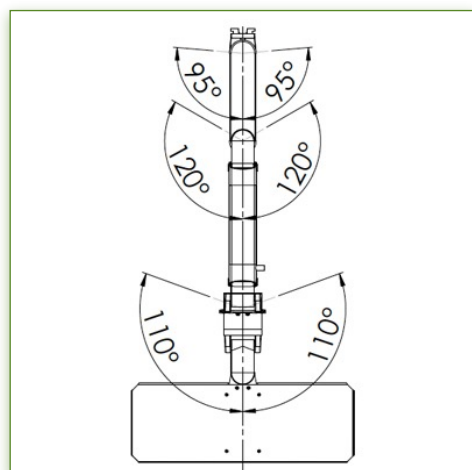

Anti-bacterial properties:

IT medical arms are now designed with Microban antibacterial protection, a revolutionary treatment that guarantees optimal hygiene. IT medical arms integrate Microban and other antibacterial agents into all medical products. It inhibits the growth of bacteria of all types. This is not a surface treatment. It is 100% in the totality of the product. It does not alter the physico-mechanical properties of the medical arm lift system. Simulations over 30 years show that 100% of the antibacterial properties are maintained. All medical articulated arms incorporate Microban. Microban is the world's leading provider of anti-bacterial solutions. It has been successfully applied for more than 35 years in a wide range of products used in the hospital, construction and food industries.

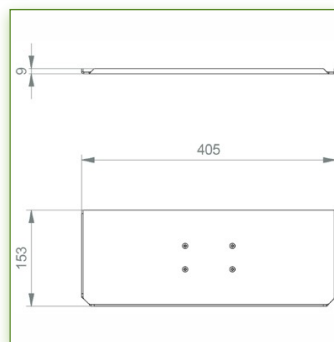
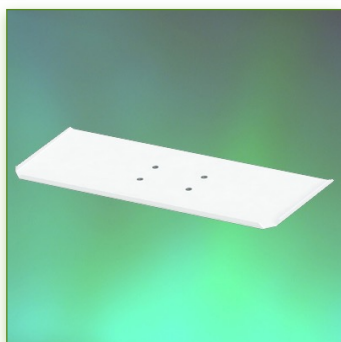
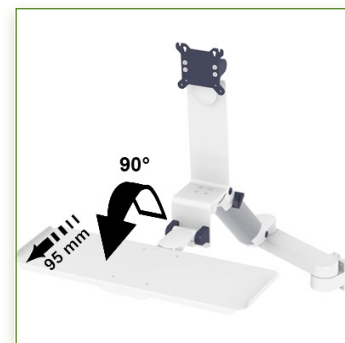

Display Compatibility: 26" Wide (Weight)
Supported Weight: 10- 11,5 Kg
VESA standard: 75 / 100 mm
Keyboard-Mouse holder: 400 x 150 mm

 Up to 26" Wide (Weight)
 75/100 mm
 10 - 11,5 Kg
 400 x 150 mm
MEDICAL GRADE
Combo Folding

Do not hesitate to contact us if you have any questions about this product.

Warranty: 5 years

000.991.692-4-2

Graphite Grey and White

On Measure

= Depending on the elements

991.692-4-2

300 + 240 mm height-adjustable Medical Combo Folding Arm for monitor, keyboard and mouse, wall mounting on vertical sliding rail

This 300 + 240 mm Folding Combo Medical Arm with gas spring height adjustment allows the LCD screen to be perfectly fixed, oriented and adjusted and supports the keyboard and mouse. It is coated with an anti-microbial agent offering hygiene and cleaning down to the last detail. Its modern design has been specially designed for healthcare environments.

Technical specifications:

- * Integrated cable channel
- * Equipotential bonding
- * Optional Vertical Wall Slide Rail Mounting available in several lengths (480 mm - 720 mm - 960 mm - 1200 mm).
- * These wall rails can be easily cut to the required size. All cables also pass through the wall rail. (See Options below)
- * This 300 + 240 mm Combo Folding Arm with gas spring simply slides into the wall rail to adjust to the desired height and fixed.
- * It has a safety height adjustment stop button, which allows the arm to remain in the chosen position.
- * The head of this arm complies with the standard for mounting screens: VESA MIS-D 75 mm and 100 mm.
- * Compatible with screens whose weight does not exceed 10 - 11,5 Kg.
- * Touch screen stability. * Screen tilt: 10°.
- * Screen rotation: 110° right, 110° left.
- * Arm rotation: 105° to the right, 105° to the left.
- * Height adjustment: 45° down, 45° up * Total length 991 - 1086 mm
- * Foldable and removable keyboard and mouse holder: 400 x 150 mm
- * Compatible with multimedia terminals (TMM)
- * Color RAL 7024 (Graphite Grey) and White
- * All our medical arms are in conformity: CE, ROHS, Medical Grade, Regulations MDD 93/42 ECC.
- * Warranty: 5 years

Note: This arm can also be installed on one of our medical columns or trolleys.



Display Compatibility: 26" Wide (Weight)
Supported Weight: 10- 11,5 Kg
VESA standard: 75 / 100 mm
Keyboard-Mouse holder: 400 x 150 mm

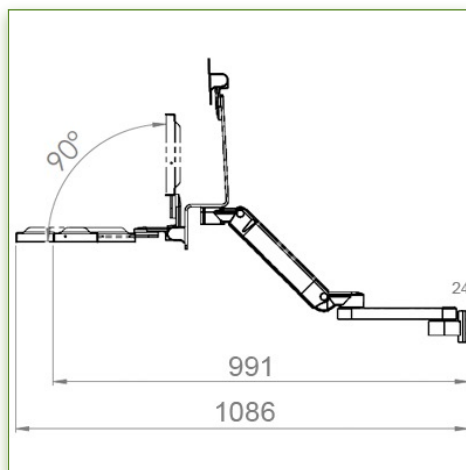
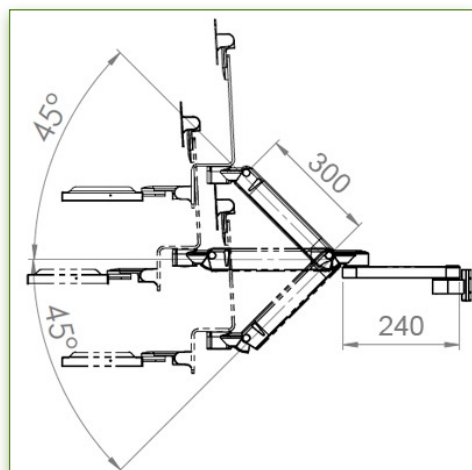
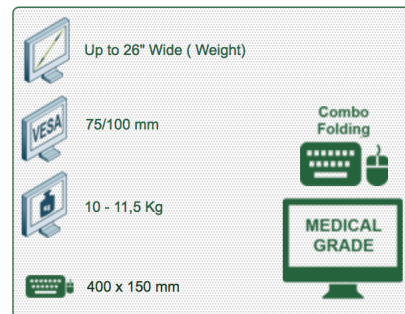

Do not hesitate to contact us if you have any questions about this product.

Warranty: 5 years

000.991.692-4-2

Graphite Grey and White

On Measure

= Depending on the elements

991.692-4-2

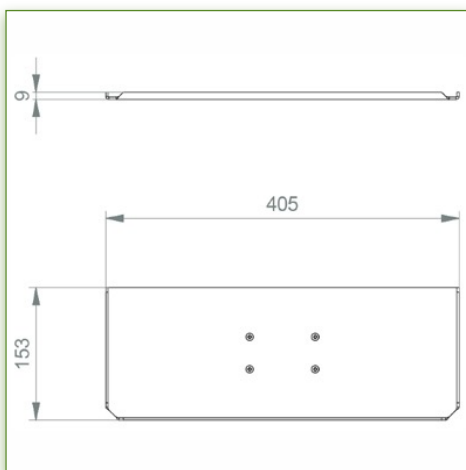
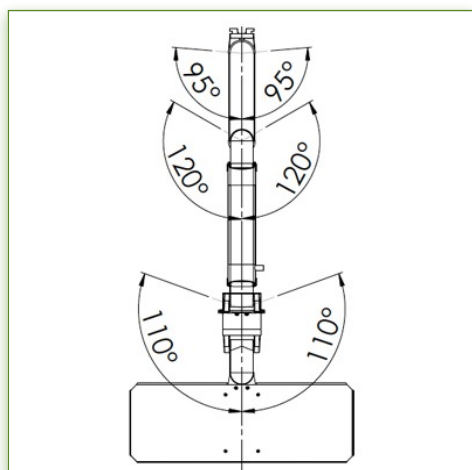

Anti-bacterial properties:

IT medical arms are now designed with Microban antibacterial protection, a revolutionary treatment that guarantees optimal hygiene. IT medical arms integrate Microban and other antibacterial agents into all medical products. It inhibits the growth of bacteria of all types. This is not a surface treatment. It is 100% in the totality of the product. It does not alter the physico-mechanical properties of the medical arm lift system. Simulations over 30 years show that 100% of the antibacterial properties are maintained. All medical articulated arms incorporate Microban. Microban is the world's leading provider of anti-bacterial solutions. It has been successfully applied for more than 35 years in a wide range of products used in the hospital, construction and food industries.

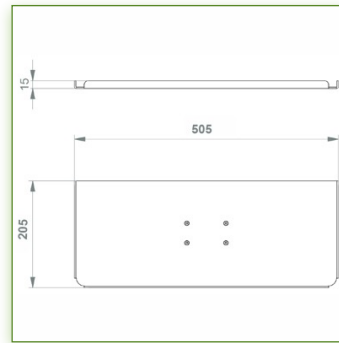
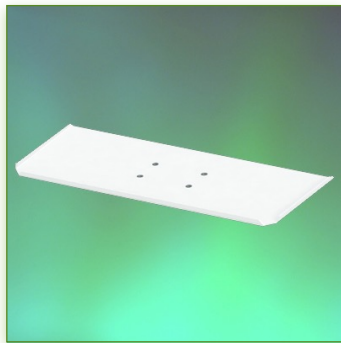
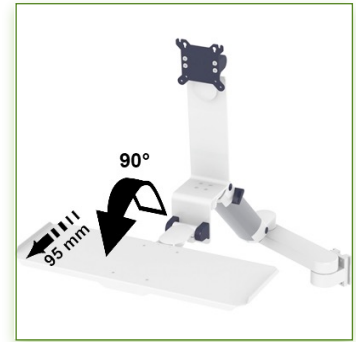

Display Compatibility: 26" Wide (Weight)
Supported Weight: 10- 11,5 Kg
VESA standard: 75 / 100 mm
Keyboard-Mouse holder: 500 x 200 mm

Up to 26" Wide (Weight)
75/100 mm
10 - 11,5 Kg
500 x 200 mm

Combo Folding
MEDICAL GRADE

Do not hesitate to contact us if you have any questions about this product.

Warranty: 5 years

000.991.692-4-3

Graphite Grey and White

On Measure

= Depending on the elements

991.692-4-3

300 + 240 mm height-adjustable Medical Combo Folding Arm for monitor, keyboard and mouse, wall mounting on vertical sliding rail

This 300 + 240 mm Folding Combo Medical Arm with gas spring height adjustment allows the LCD screen to be perfectly fixed, oriented and adjusted and supports the keyboard and mouse. It is coated with an anti-microbial agent offering hygiene and cleaning down to the last detail. Its modern design has been specially designed for healthcare environments.

Technical specifications:

- * Integrated cable channel
- * Equipotential bonding
- * Optional Vertical Wall Slide Rail Mounting available in several lengths (480 mm - 720 mm - 960 mm - 1200 mm).
- * These wall rails can be easily cut to the required size. All cables also pass through the wall rail. (See Options below)
- * This 300 + 240 mm Combo Folding Arm with gas spring simply slides into the wall rail to adjust to the desired height and fixed.
- * It has a safety height adjustment stop button, which allows the arm to remain in the chosen position.
- * The head of this arm complies with the standard for mounting screens: VESA MIS-D 75 mm and 100 mm.
- * Compatible with screens whose weight does not exceed 10 - 11,5 Kg.
- * Touch screen stability. * Screen tilt: 10°.
- * Screen rotation: 110° right, 110° left.
- * Arm rotation: 105° to the right, 105° to the left.
- * Height adjustment: 45° down, 45° up * Total length 991 - 1086 mm
- * Foldable and removable keyboard and mouse holder: 500 x 200 mm
- * Compatible with multimedia terminals (TMM)
- * Color RAL 7024 (Graphite Grey) and White
- * All our medical arms are in conformity: CE, ROHS, Medical Grade, Regulations MDD 93/42 ECC.
- * Warranty: 5 years

Note: This arm can also be installed on one of our medical columns or trolleys.



Display Compatibility: 26" Wide (Weight)
Supported Weight: 10- 11,5 Kg
VESA standard: 75 / 100 mm
Keyboard-Mouse holder: 500 x 200 mm

 Up to 26" Wide (Weight)
 75/100 mm
 10 - 11,5 Kg
 500 x 200 mm
MEDICAL GRADE

Do not hesitate to contact us if you have any questions about this product.

Warranty: 5 years

000.991.692-4-3

Graphite Grey and White

On Measure

= Depending on the elements

991.692-4-3

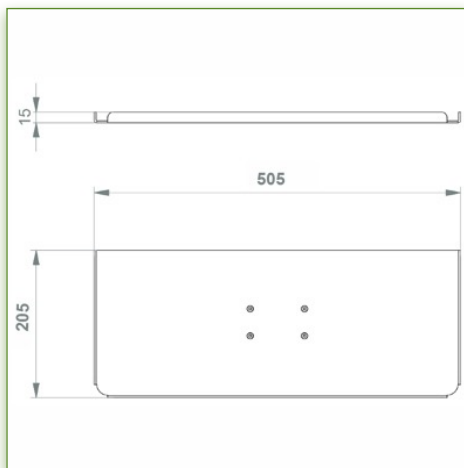
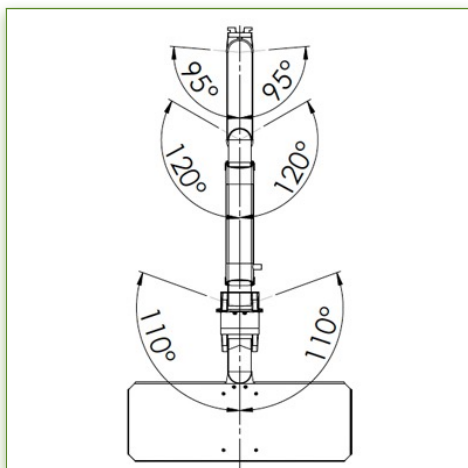
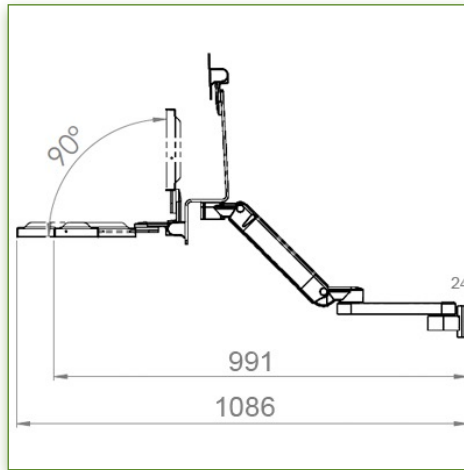
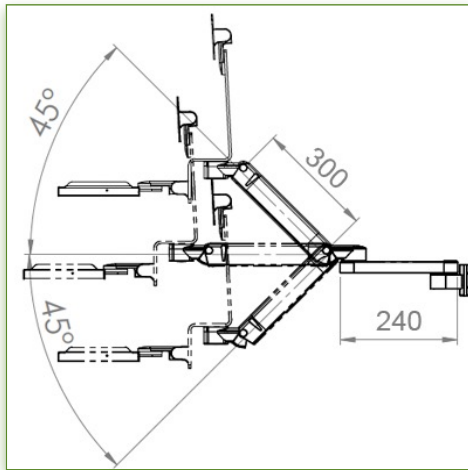

Anti-bacterial properties:

IT medical arms are now designed with Microban antibacterial protection, a revolutionary treatment that guarantees optimal hygiene. IT medical arms integrate Microban and other antibacterial agents into all medical products. It inhibits the growth of bacteria of all types. This is not a surface treatment. It is 100% in the totality of the product. It does not alter the physico-mechanical properties of the medical arm lift system. Simulations over 30 years show that 100% of the antibacterial properties are maintained. All medical articulated arms incorporate Microban. Microban is the world's leading provider of anti-bacterial solutions. It has been successfully applied for more than 35 years in a wide range of products used in the hospital, construction and food industries.

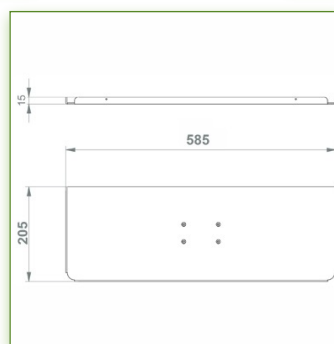
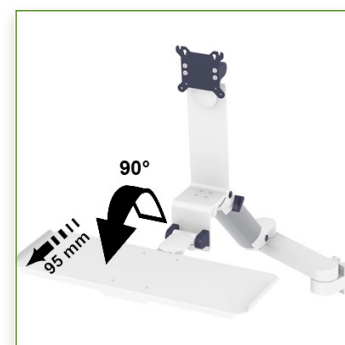

Display Compatibility: 26" Wide (Weight)
Supported Weight: 10- 11,5 Kg
VESA standard: 75 / 100 mm
Keyboard-Mouse holder: 580 x 200 mm

 Up to 26" Wide (Weight)
 75/100 mm
 10 - 11,5 Kg
 580 x 200 mm
 MEDICAL GRADE
 Combo Folding

Do not hesitate to contact us if you have any questions about this product.

Warranty: 5 years

000.991.692-4-4

Graphite Grey and White

On Measure

= Depending on the elements

991.692-4-4

300 + 240 mm height-adjustable Medical Combo Folding Arm for monitor, keyboard and mouse, wall mounting on vertical sliding rail

This 300 + 240 mm Folding Combo Medical Arm with gas spring height adjustment allows the LCD screen to be perfectly fixed, oriented and adjusted and supports the keyboard and mouse. It is coated with an anti-microbial agent offering hygiene and cleaning down to the last detail. Its modern design has been specially designed for healthcare environments.

Technical specifications:

- * Integrated cable channel
- * Equipotential bonding
- * Optional Vertical Wall Slide Rail Mounting available in several lengths (480 mm - 720 mm - 960 mm - 1200 mm).
- * These wall rails can be easily cut to the required size. All cables also pass through the wall rail. (See Options below)
- * This 300 + 240 mm Combo Folding Arm with gas spring simply slides into the wall rail to adjust to the desired height and fixed.
- * It has a safety height adjustment stop button, which allows the arm to remain in the chosen position.
- * The head of this arm complies with the standard for mounting screens: VESA MIS-D 75 mm and 100 mm.
- * Compatible with screens whose weight does not exceed 10 - 11,5 Kg.
- * Touch screen stability. * Screen tilt: 10°.
- * Screen rotation: 110° right, 110° left.
- * Arm rotation: 105° to the right, 105° to the left.
- * Height adjustment: 45° down, 45° up * Total length 991 - 1086 mm
- * Foldable and removable keyboard and mouse holder: 580 x 200 mm
- * Compatible with multimedia terminals (TMM)
- * Color RAL 7024 (Graphite Grey) and White
- * All our medical arms are in conformity: CE, ROHS, Medical Grade, Regulations MDD 93/42 ECC.
- * Warranty: 5 years

Note: This arm can also be installed on one of our medical columns or trolleys.



Display Compatibility: 26" Wide (Weight)
Supported Weight: 10- 11,5 Kg
VESA standard: 75 / 100 mm
Keyboard-Mouse holder: 580 x 200 mm

Up to 26" Wide (Weight)
75/100 mm
10 - 11,5 Kg
580 x 200 mm

Combo Folding
MEDICAL GRADE

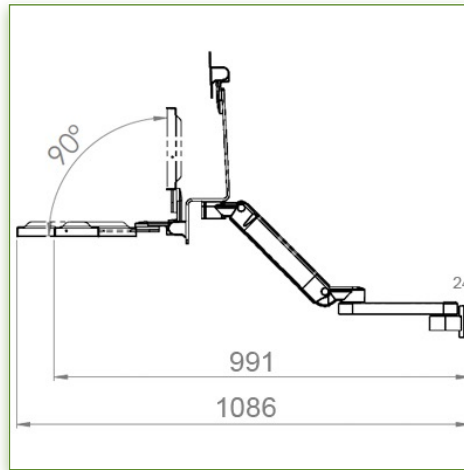
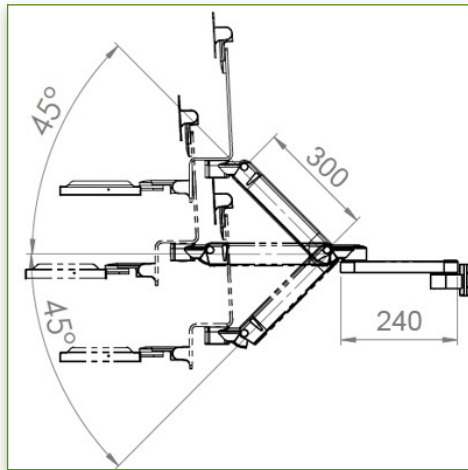

Do not hesitate to contact us if you have any questions about this product.



Warranty: 5 years



000.991.692-4-4



Graphite Grey and White



On Measure



= Depending on the elements



991.692-4-4

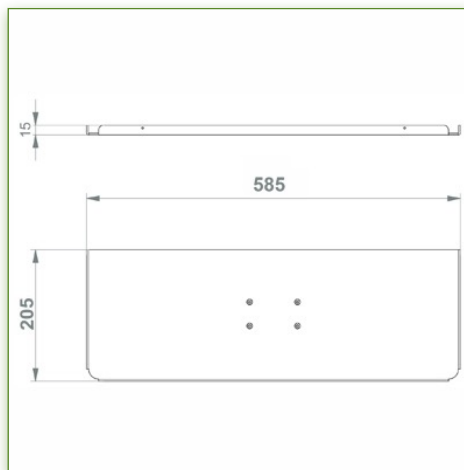
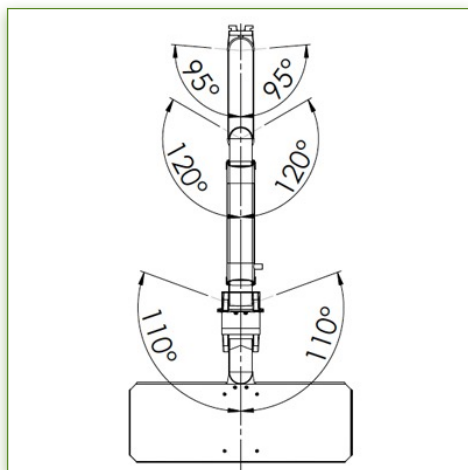

Anti-bacterial properties:

IT medical arms are now designed with Microban antibacterial protection, a revolutionary treatment that guarantees optimal hygiene. IT medical arms integrate Microban and other antibacterial agents into all medical products. It inhibits the growth of bacteria of all types. This is not a surface treatment. It is 100% in the totality of the product. It does not alter the physico-mechanical properties of the medical arm lift system. Simulations over 30 years show that 100% of the antibacterial properties are maintained. All medical articulated arms incorporate Microban. Microban is the world's leading provider of anti-bacterial solutions. It has been successfully applied for more than 35 years in a wide range of products used in the hospital, construction and food industries.

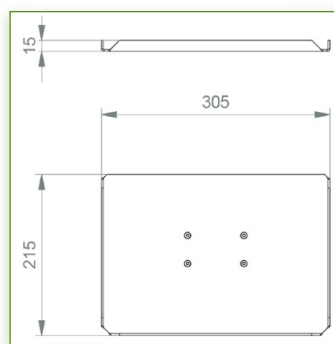
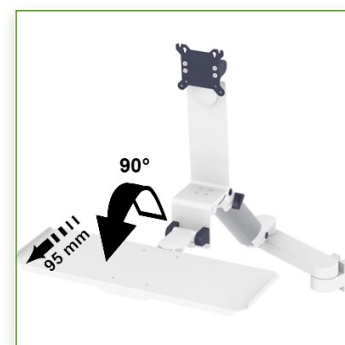

Display Compatibility: 26" Wide (Weight)
Supported Weight: 11- 15,5 Kg
VESA standard: 75 / 100 mm
Keyboard-Mouse holder: 300 x 210 mm

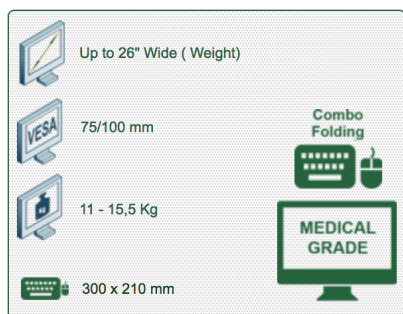

Do not hesitate to contact us if you have any questions about this product.

Warranty: 5 years

000.991.692-5-1

Graphite Grey and White

On Measure

= Depending on the elements

991.692-5-1

300 + 240 mm height-adjustable Medical Combo Folding Arm for monitor, keyboard and mouse, wall mounting on vertical sliding rail

This 300 + 240 mm Folding Combo Medical Arm with gas spring height adjustment allows the LCD screen to be perfectly fixed, oriented and adjusted and supports the keyboard and mouse. It is coated with an anti-microbial agent offering hygiene and cleaning down to the last detail. Its modern design has been specially designed for healthcare environments.

Technical specifications:

- * Integrated cable channel
- * Equipotential bonding
- * Optional Vertical Wall Slide Rail Mounting available in several lengths (480 mm - 720 mm - 960 mm - 1200 mm).
- * These wall rails can be easily cut to the required size. All cables also pass through the wall rail. (See Options below)
- * This 300 + 240 mm Combo Folding Arm with gas spring simply slides into the wall rail to adjust to the desired height and fixed.
- * It has a safety height adjustment stop button, which allows the arm to remain in the chosen position.
- * The head of this arm complies with the standard for mounting screens: VESA MIS-D 75 mm and 100 mm.
- * Compatible with screens whose weight does not exceed 11 - 15,5 Kg.
- * Touch screen stability. * Screen tilt: 10°.
- * Screen rotation: 110° right, 110° left.
- * Arm rotation: 105° to the right, 105° to the left.
- * Height adjustment: 45° down, 45° up * Total length 991 - 1086 mm
- * Foldable and removable keyboard and mouse holder: 300 x 210 mm
- * Compatible with multimedia terminals (TMM)
- * Color RAL 7024 (Graphite Grey) and White
- * All our medical arms are in conformity: CE, ROHS, Medical Grade, Regulations MDD 93/42 ECC.
- * Warranty: 5 years

Note: This arm can also be installed on one of our medical columns or trolleys.



Display Compatibility: 26" Wide (Weight)
Supported Weight: 11- 15,5 Kg
VESA standard: 75 / 100 mm
Keyboard-Mouse holder: 300 x 210 mm

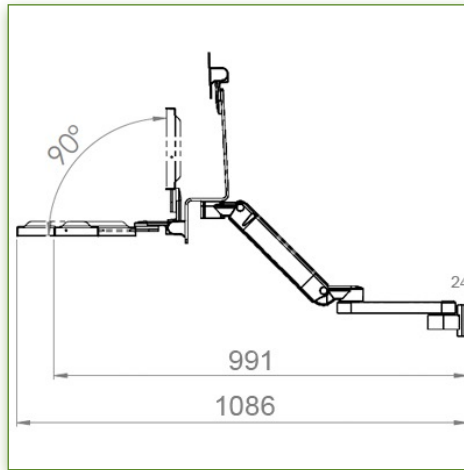
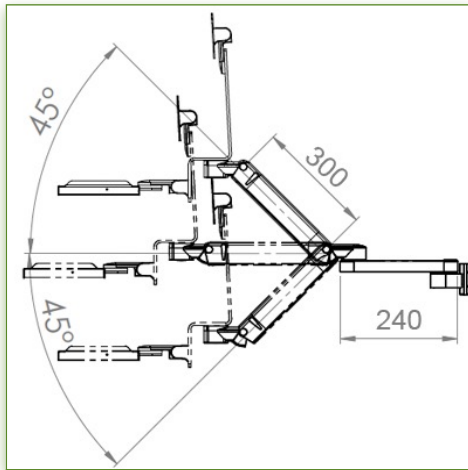
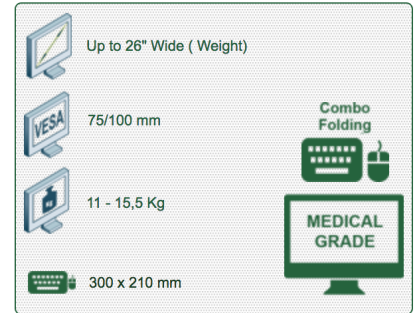

Do not hesitate to contact us if you have any questions about this product.

Warranty: 5 years

000.991.692-5-1

Graphite Grey and White

On Measure

= Depending on the elements

991.692-5-1

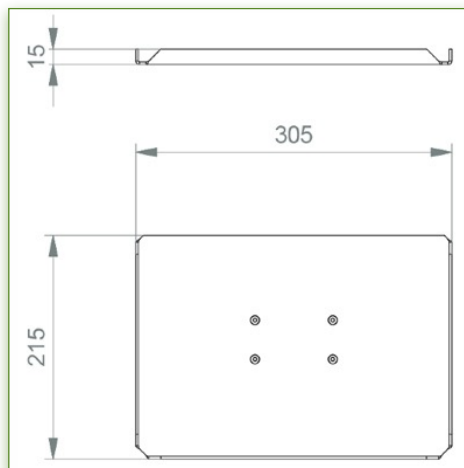
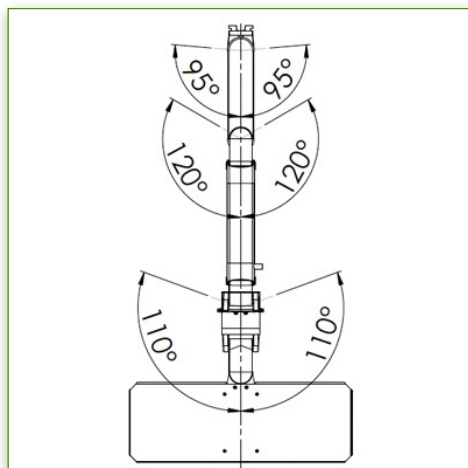

Anti-bacterial properties:

IT medical arms are now designed with Microban antibacterial protection, a revolutionary treatment that guarantees optimal hygiene. IT medical arms integrate Microban and other antibacterial agents into all medical products. It inhibits the growth of bacteria of all types. This is not a surface treatment. It is 100% in the totality of the product. It does not alter the physico-mechanical properties of the medical arm lift system. Simulations over 30 years show that 100% of the antibacterial properties are maintained. All medical articulated arms incorporate Microban. Microban is the world's leading provider of anti-bacterial solutions. It has been successfully applied for more than 35 years in a wide range of products used in the hospital, construction and food industries.

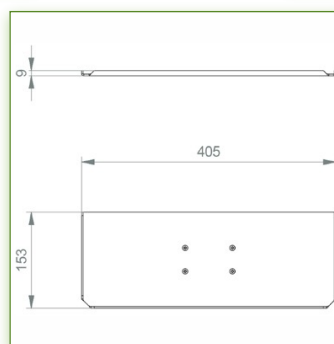
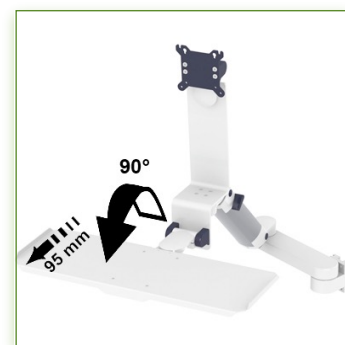

Display Compatibility: 26" Wide (Weight)
Supported Weight: 11- 15,5 Kg
VESA standard: 75 / 100 mm
Keyboard-Mouse holder: 400 x 150 mm

 Up to 26" Wide (Weight))
 75/100 mm
 11 - 15,5 Kg
 400 x 150 mm
 MEDICAL GRADE
 Combo Folding

Do not hesitate to contact us if you have any questions about this product.

Warranty: 5 years

000.991.692-5-2

Graphite Grey and White

On Measure

= Depending on the elements

991.692-5-2

300 + 240 mm height-adjustable Medical Combo Folding Arm for monitor, keyboard and mouse, wall mounting on vertical sliding rail

This 300 + 240 mm Folding Combo Medical Arm with gas spring height adjustment allows the LCD screen to be perfectly fixed, oriented and adjusted and supports the keyboard and mouse. It is coated with an anti-microbial agent offering hygiene and cleaning down to the last detail. Its modern design has been specially designed for healthcare environments.

Technical specifications:

- * Integrated cable channel
- * Equipotential bonding
- * Optional Vertical Wall Slide Rail Mounting available in several lengths (480 mm - 720 mm - 960 mm - 1200 mm).
- * These wall rails can be easily cut to the required size. All cables also pass through the wall rail. (See Options below)
- * This 300 + 240 mm Combo Folding Arm with gas spring simply slides into the wall rail to adjust to the desired height and fixed.
- * It has a safety height adjustment stop button, which allows the arm to remain in the chosen position.
- * The head of this arm complies with the standard for mounting screens: VESA MIS-D 75 mm and 100 mm.
- * Compatible with screens whose weight does not exceed 11 - 15,5 Kg.
- * Touch screen stability. * Screen tilt: 10°.
- * Screen rotation: 110° right, 110° left.
- * Arm rotation: 105° to the right, 105° to the left.
- * Height adjustment: 45° down, 45° up * Total length 991 - 1086 mm
- * Foldable and removable keyboard and mouse holder: 400 x 150 mm
- * Compatible with multimedia terminals (TMM)
- * Color RAL 7024 (Graphite Grey) and White
- * All our medical arms are in conformity: CE, ROHS, Medical Grade, Regulations MDD 93/42 ECC.
- * Warranty: 5 years

Note: This arm can also be installed on one of our medical columns or trolleys.

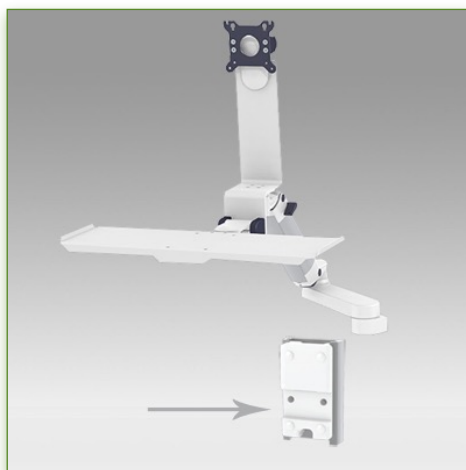

Display Compatibility: 26" Wide (Weight)
 Supported Weight: 11- 15,5 Kg
 VESA standard: 75 / 100 mm
 Keyboard-Mouse holder: 400 x 150 mm

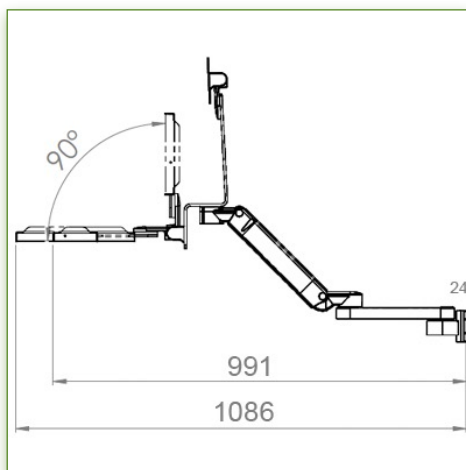
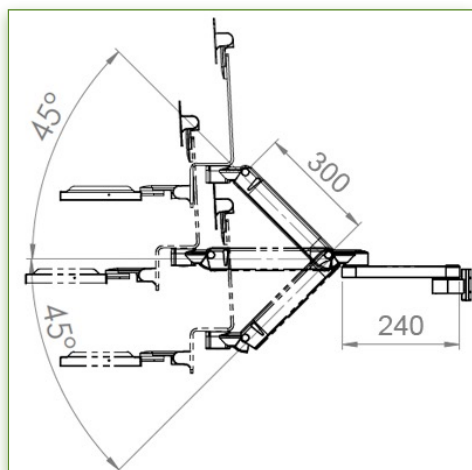
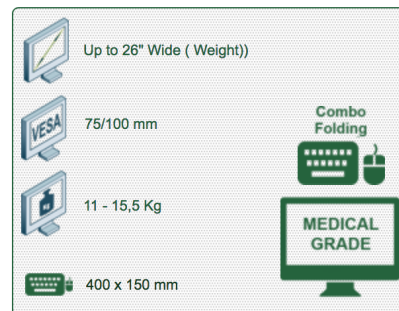

Medical Grade

Do not hesitate to contact us if you have any questions about this product.

Warranty: 5 years

000.991.692-5-2

Graphite Grey and White

On Measure

= Depending on the elements

991.692-5-2

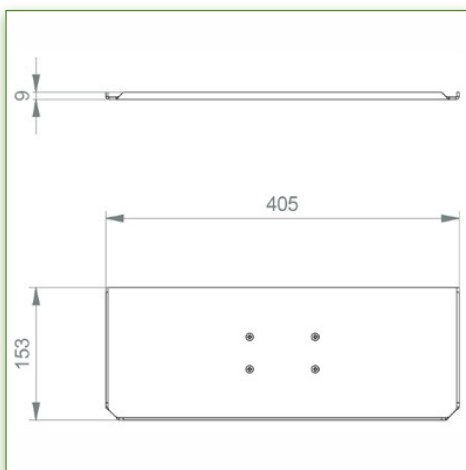
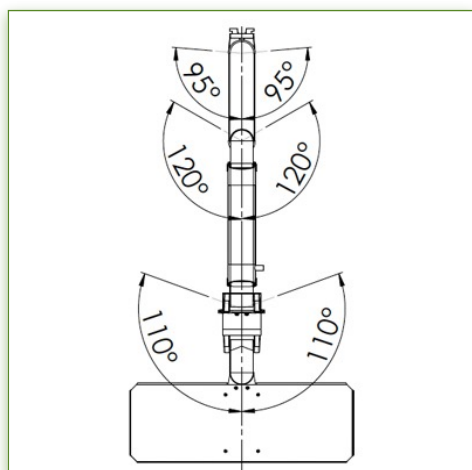

Anti-bacterial properties:

IT medical arms are now designed with Microban antibacterial protection, a revolutionary treatment that guarantees optimal hygiene. IT medical arms integrate Microban and other antibacterial agents into all medical products. It inhibits the growth of bacteria of all types. This is not a surface treatment. It is 100% in the totality of the product. It does not alter the physico-mechanical properties of the medical arm lift system. Simulations over 30 years show that 100% of the antibacterial properties are maintained. All medical articulated arms incorporate Microban. Microban is the world's leading provider of anti-bacterial solutions. It has been successfully applied for more than 35 years in a wide range of products used in the hospital, construction and food industries.

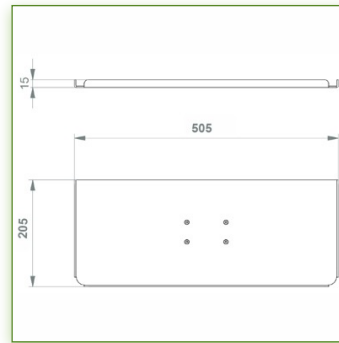
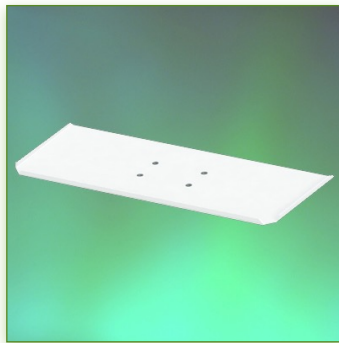
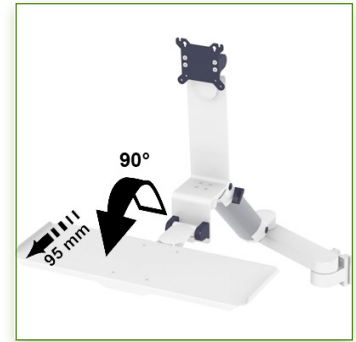

Display Compatibility: 26" Wide (Weight)
Supported Weight: 11- 15,5 Kg
VESA standard: 75 / 100 mm
Keyboard-Mouse holder: 500 x 200 mm

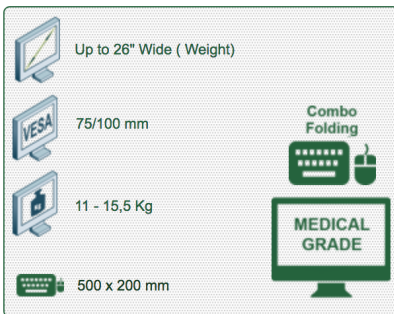

Do not hesitate to contact us if you have any questions about this product.

Warranty: 5 years

000.991.692-5-3

Graphite Grey and White

On Measure

= Depending on the elements

991.692-5-3

300 + 240 mm height-adjustable Medical Combo Folding Arm for monitor, keyboard and mouse, wall mounting on vertical sliding rail

This 300 + 240 mm Folding Combo Medical Arm with gas spring height adjustment allows the LCD screen to be perfectly fixed, oriented and adjusted and supports the keyboard and mouse. It is coated with an anti-microbial agent offering hygiene and cleaning down to the last detail. Its modern design has been specially designed for healthcare environments.

Technical specifications:

- * Integrated cable channel
- * Equipotential bonding
- * Optional Vertical Wall Slide Rail Mounting available in several lengths (480 mm - 720 mm - 960 mm - 1200 mm).
- * These wall rails can be easily cut to the required size. All cables also pass through the wall rail. (See Options below)
- * This 300 + 240 mm Combo Folding Arm with gas spring simply slides into the wall rail to adjust to the desired height and fixed.
- * It has a safety height adjustment stop button, which allows the arm to remain in the chosen position.
- * The head of this arm complies with the standard for mounting screens: VESA MIS-D 75 mm and 100 mm.
- * Compatible with screens whose weight does not exceed 11 - 15,5 Kg.
- * Touch screen stability. * Screen tilt: 10°.
- * Screen rotation: 110° right, 110° left.
- * Arm rotation: 105° to the right, 105° to the left.
- * Height adjustment: 45° down, 45° up * Total length 991 - 1086 mm
- * Foldable and removable keyboard and mouse holder: 500 x 200 mm
- * Compatible with multimedia terminals (TMM)
- * Color RAL 7024 (Graphite Grey) and White
- * All our medical arms are in conformity: CE, ROHS, Medical Grade, Regulations MDD 93/42 ECC.
- * Warranty: 5 years

Note: This arm can also be installed on one of our medical columns or trolleys.



Display Compatibility: 26" Wide (Weight)
Supported Weight: 11- 15,5 Kg
VESA standard: 75 / 100 mm
Keyboard-Mouse holder: 500 x 200 mm

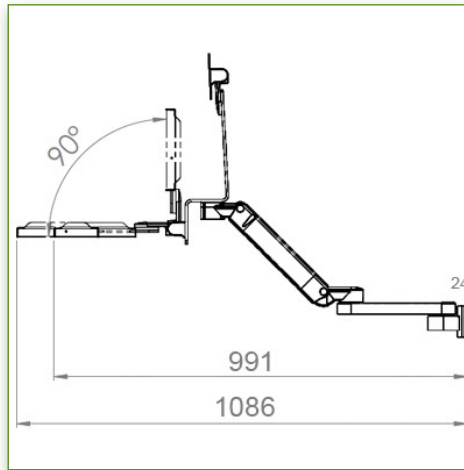
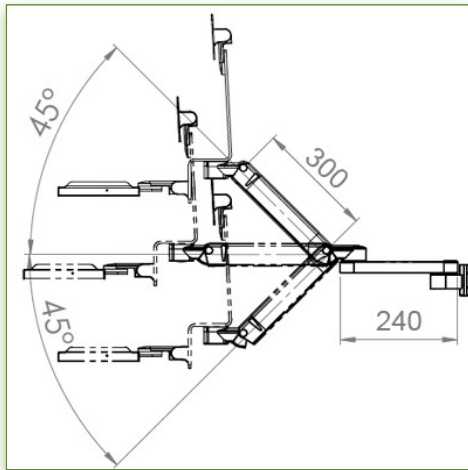
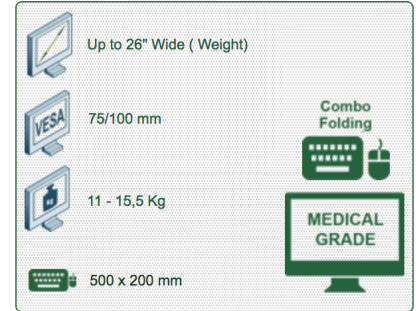

Do not hesitate to contact us if you have any questions about this product.

Warranty: 5 years

000.991.692-5-3

Graphite Grey and White

On Measure

= Depending on the elements

991.692-5-3

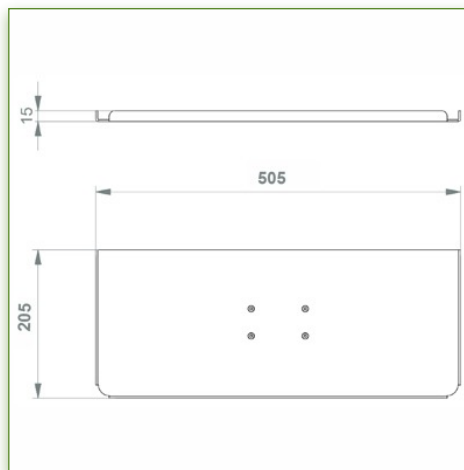
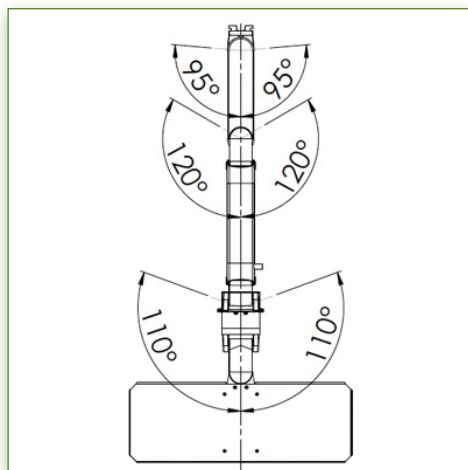

Anti-bacterial properties:

IT medical arms are now designed with Microban antibacterial protection, a revolutionary treatment that guarantees optimal hygiene. IT medical arms integrate Microban and other antibacterial agents into all medical products. It inhibits the growth of bacteria of all types. This is not a surface treatment. It is 100% in the totality of the product. It does not alter the physico-mechanical properties of the medical arm lift system. Simulations over 30 years show that 100% of the antibacterial properties are maintained. All medical articulated arms incorporate Microban. Microban is the world's leading provider of anti-bacterial solutions. It has been successfully applied for more than 35 years in a wide range of products used in the hospital, construction and food industries.

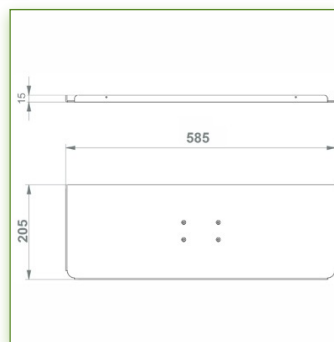
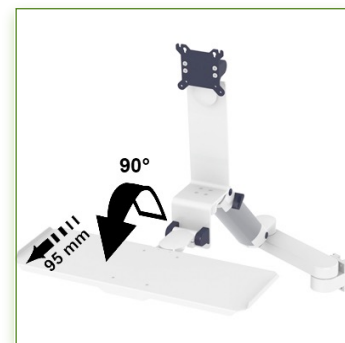

Display Compatibility: 26" Wide (Weight)
Supported Weight: 11- 15,5 Kg
VESA standard: 75 / 100 mm
Keyboard-Mouse holder: 580 x 200 mm

Up to 26" Wide (Weight)
75/100 mm
11 - 15,5 Kg
580 x 200 mm

Combo Folding
MEDICAL GRADE

Do not hesitate to contact us if you have any questions about this product.

Warranty: 5 years

000.991.692-5-4

Graphite Grey and White

On Measure

= Depending on the elements

991.692-5-4

300 + 240 mm height-adjustable Medical Combo Folding Arm for monitor, keyboard and mouse, wall mounting on vertical sliding rail

This 300 + 240 mm Folding Combo Medical Arm with gas spring height adjustment allows the LCD screen to be perfectly fixed, oriented and adjusted and supports the keyboard and mouse. It is coated with an anti-microbial agent offering hygiene and cleaning down to the last detail. Its modern design has been specially designed for healthcare environments.

Technical specifications:

- * Integrated cable channel
- * Equipotential bonding
- * Optional Vertical Wall Slide Rail Mounting available in several lengths (480 mm - 720 mm - 960 mm - 1200 mm).
- * These wall rails can be easily cut to the required size. All cables also pass through the wall rail. (See Options below)
- * This 300 + 240 mm Combo Folding Arm with gas spring simply slides into the wall rail to adjust to the desired height and fixed.
- * It has a safety height adjustment stop button, which allows the arm to remain in the chosen position.
- * The head of this arm complies with the standard for mounting screens: VESA MIS-D 75 mm and 100 mm.
- * Compatible with screens whose weight does not exceed 11 - 15,5 Kg.
- * Touch screen stability. * Screen tilt: 10°.
- * Screen rotation: 110° right, 110° left.
- * Arm rotation: 105° to the right, 105° to the left.
- * Height adjustment: 45° down, 45° up * Total length 991 - 1086 mm
- * Foldable and removable keyboard and mouse holder: 580 x 200 mm
- * Compatible with multimedia terminals (TMM)
- * Color RAL 7024 (Graphite Grey) and White
- * All our medical arms are in conformity: CE, ROHS, Medical Grade, Regulations MDD 93/42 ECC.
- * Warranty: 5 years

Note: This arm can also be installed on one of our medical columns or trolleys.



Display Compatibility: 26" Wide (Weight)
Supported Weight: 11- 15,5 Kg
VESA standard: 75 / 100 mm
Keyboard-Mouse holder: 580 x 200 mm

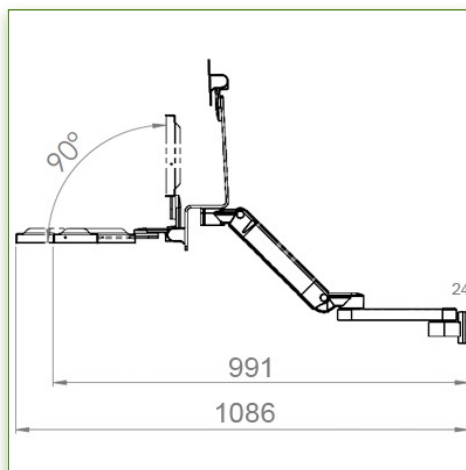
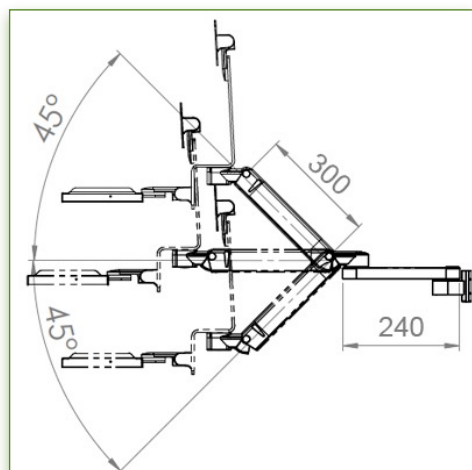
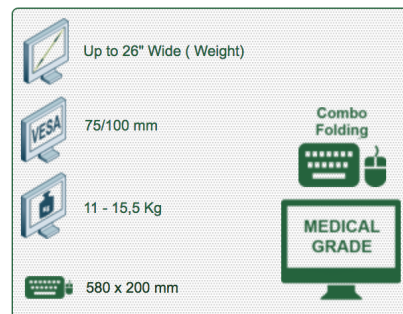

Do not hesitate to contact us if you have any questions about this product.

Warranty: 5 years

000.991.692-5-4

Graphite Grey and White

On Measure

= Depending on the elements

991.692-5-4

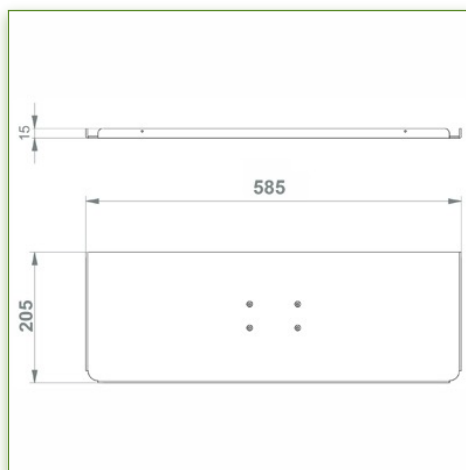
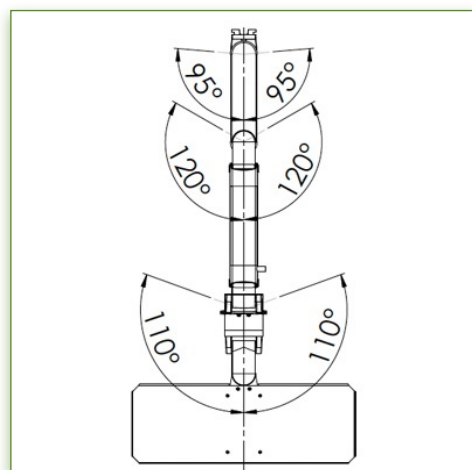

Anti-bacterial properties:

IT medical arms are now designed with Microban antibacterial protection, a revolutionary treatment that guarantees optimal hygiene. IT medical arms integrate Microban and other antibacterial agents into all medical products. It inhibits the growth of bacteria of all types. This is not a surface treatment. It is 100% in the totality of the product. It does not alter the physico-mechanical properties of the medical arm lift system. Simulations over 30 years show that 100% of the antibacterial properties are maintained. All medical articulated arms incorporate Microban. Microban is the world's leading provider of anti-bacterial solutions. It has been successfully applied for more than 35 years in a wide range of products used in the hospital, construction and food industries.

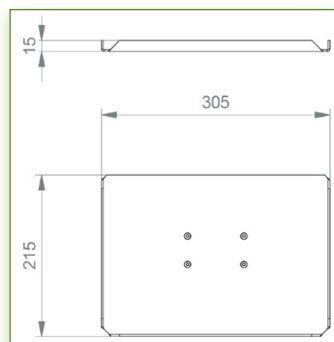
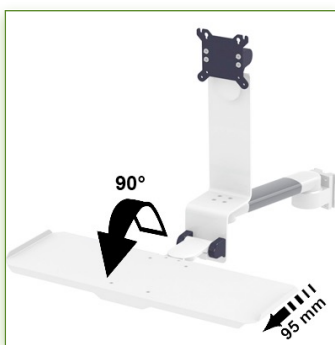
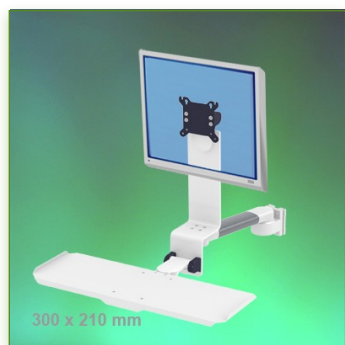

Display Compatibility: 26" Wide (Weight)
Supported Weight: 18 Kg
VESA standard: 75 / 100 mm
Keyboard-Mouse holder: 300 x 210 mm

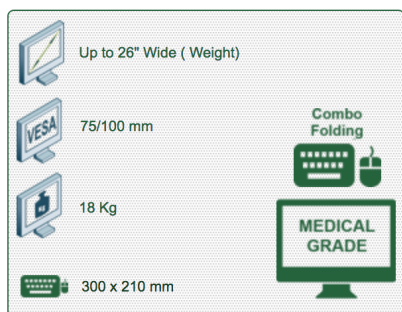

Do not hesitate to contact us if you have any questions about this product.

Warranty: 5 years

000.991.657-1

Graphite Grey and White

On Measure

= Depending on the elements

991.657-1

Medical Arm Combo Horizontal Foldable 240 mm for screen, keyboard and mouse, wall mounting on vertical sliding rail

This 240 mm Folding Combo Arm allows the LCD screen to be perfectly fixed, oriented and adjusted and supports the keyboard and mouse. It is coated with an anti-microbial agent offering hygiene and cleaning down to the last detail. Its modern design has been specially designed for healthcare environments.

Technical specifications:

- * Integrated cable channel
- * Optional Vertical Wall Slide Rail Mounting available in several lengths (480 mm - 720 mm - 960 mm - 1200 mm).
- * These wall rails can be easily cut to the required size. All cables also pass through the wall rail (See Options below)
- * This 240 mm Folding Combo Arm simply slides into the wall rail to adjust to the desired height and fixed.
- * It does not have height adjustment, but has two horizontal axes of rotation.
- * The head of this arm complies with the standard for mounting screens: VESA MIS-D 75 mm and 100 mm. * Tilt head.
- * Compatible with screens whose weight does not exceed 18 Kg.
- * Touch screen stability. * Screen tilt: 10°.
- * Screen rotation: 110° right, 110° left.
- * Arm rotation: 105° to the right, 105° to the left.
- * * Total length 660 - 755.5 mm
- * Foldable and removable keyboard and mouse holder: 300 x 210 mm
- * Compatible with multimedia terminals (TMM)
- * Color RAL 7024 (Graphite Grey) and White
- * All our medical arms are in conformity: CE, ROHS, Medical Grade, Regulations MDD 93/42 ECC.
- * Warranty: 5 years

Note: This arm can also be installed on one of our medical columns or trolleys.

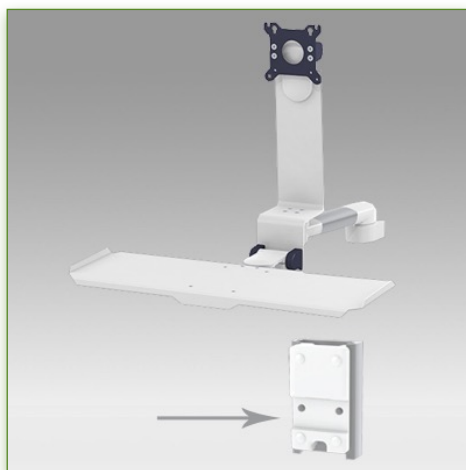
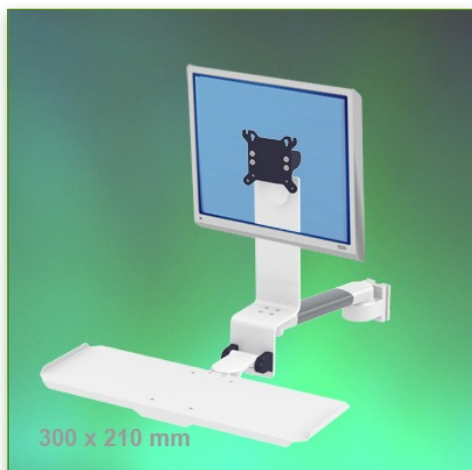

Display Compatibility: 26" Wide (Weight)
 Supported Weight: 18 Kg
 VESA standard: 75 / 100 mm
 Keyboard-Mouse holder: 300 x 210 mm

Up to 26" Wide (Weight)
 75/100 mm
 18 Kg
 300 x 210 mm

Combo Folding

MEDICAL GRADE

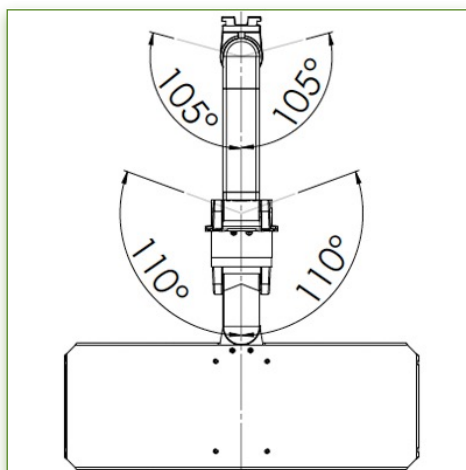
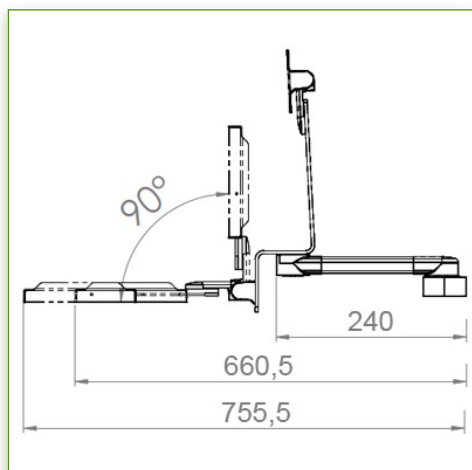

Do not hesitate to contact us if you have any questions about this product.

- Warranty: 5 years
- 000.991.657-1
- Graphite Grey and White
- On Measure
- = Depending on the elements
- 991.657-1

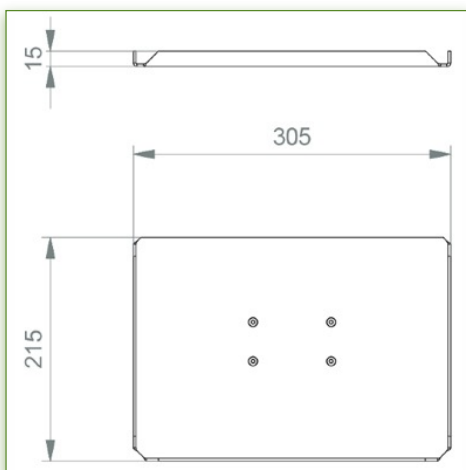

Anti-bacterial properties:

IT medical arms are now designed with Microban antibacterial protection, a revolutionary treatment that guarantees optimal hygiene. IT medical arms integrate Microban and other antibacterial agents into all medical products. It inhibits the growth of bacteria of all types. This is not a surface treatment. It is 100% in the totality of the product. It does not alter the physico-mechanical properties of the medical arm lift system. Simulations over 30 years show that 100% of the antibacterial properties are maintained. All medical articulated arms incorporate Microban. Microban is the world's leading provider of anti-bacterial solutions. It has been successfully applied for more than 35 years in a wide range of products used in the hospital, construction and food industries.

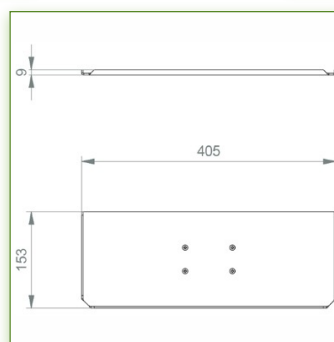
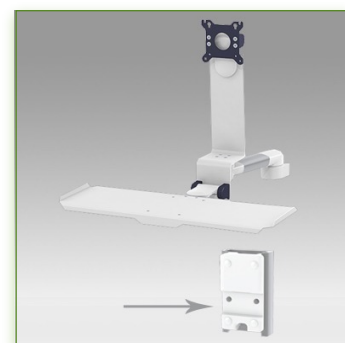
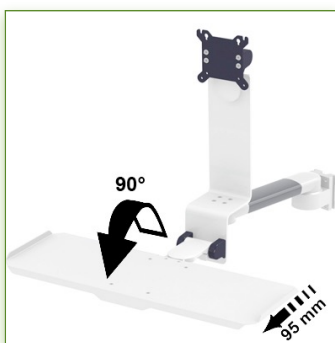
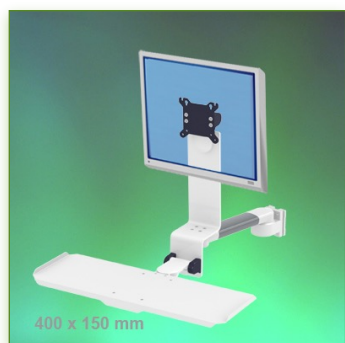

Display Compatibility: 26" Wide (Weight)
Supported Weight: 18 Kg
VESA standard: 75 / 100 mm
Keyboard-Mouse holder: 400 x 150 mm

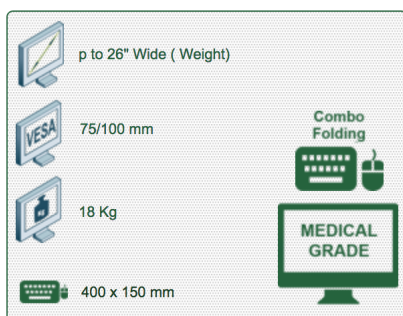

Do not hesitate to contact us if you have any questions about this product.

Warranty: 5 years

000.991.657-2

Graphite Grey and White

On Measure

= Depending on the elements

991.657-2

Medical Arm Combo Horizontal Foldable 240 mm for screen, keyboard and mouse, wall mounting on vertical sliding rail

This 240 mm Folding Combo Arm allows the LCD screen to be perfectly fixed, oriented and adjusted and supports the keyboard and mouse. It is coated with an anti-microbial agent offering hygiene and cleaning down to the last detail. Its modern design has been specially designed for healthcare environments.

Technical specifications:

- * Integrated cable channel
- * Optional Vertical Wall Slide Rail Mounting available in several lengths (480 mm - 720 mm - 960 mm - 1200 mm).
- * These wall rails can be easily cut to the required size. All cables also pass through the wall rail (See Options below)
- * This 240 mm Folding Combo Arm simply slides into the wall rail to adjust to the desired height and fixed.
- * It does not have height adjustment, but has two horizontal axes of rotation.
- * The head of this arm complies with the standard for mounting screens: VESA MIS-D 75 mm and 100 mm. * Tilt head.
- * Compatible with screens whose weight does not exceed 18 Kg.
- * Touch screen stability. * Screen tilt: 10°.
- * Screen rotation: 110° right, 110° left.
- * Arm rotation: 105° to the right, 105° to the left.
- * * Total length 660 - 755.5 mm
- * Foldable and removable keyboard and mouse holder: 400 x 150 mm
- * Compatible with multimedia terminals (TMM)
- * Color RAL 7024 (Graphite Grey) and White
- * All our medical arms are in conformity: CE, ROHS, Medical Grade, Regulations MDD 93/42 ECC.
- * Warranty: 5 years

Note: This arm can also be installed on one of our medical columns or trolleys.

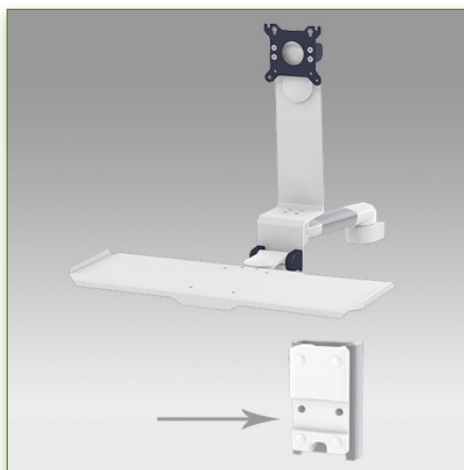
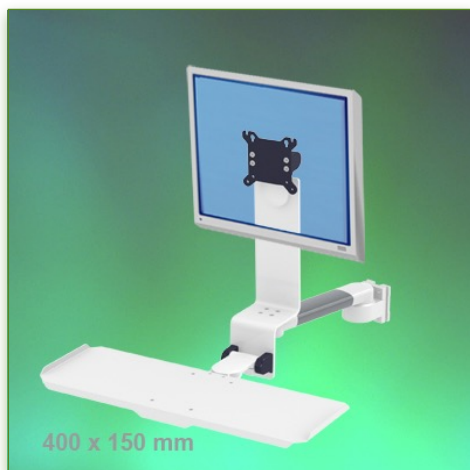

Display Compatibility: 26" Wide (Weight)
Supported Weight: 18 Kg
VESA standard: 75 / 100 mm
Keyboard-Mouse holder: 400 x 150 mm

p to 26" Wide (Weight)
75/100 mm
18 Kg
400 x 150 mm

Combo Folding

MEDICAL GRADE

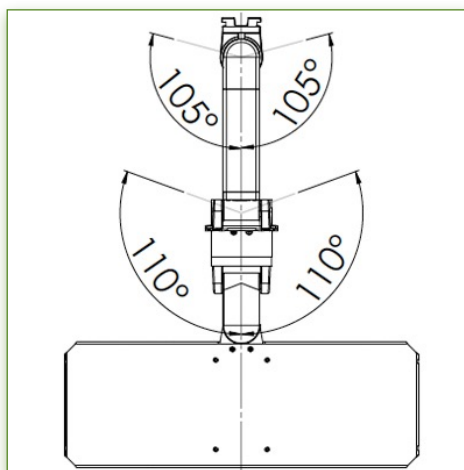
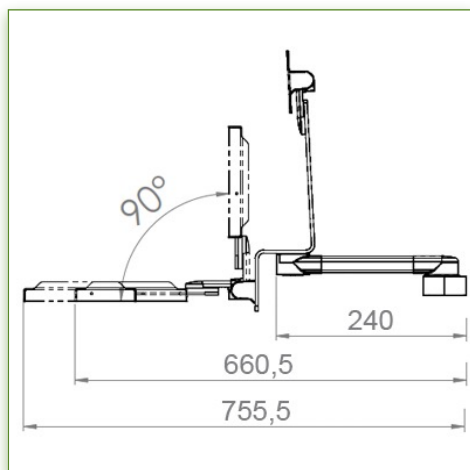

Do not hesitate to contact us if you have any questions about this product.

- Warranty: 5 years
- 000.991.657-2
- Graphite Grey and White
- On Measure
- = Depending on the elements
- 991.657-2

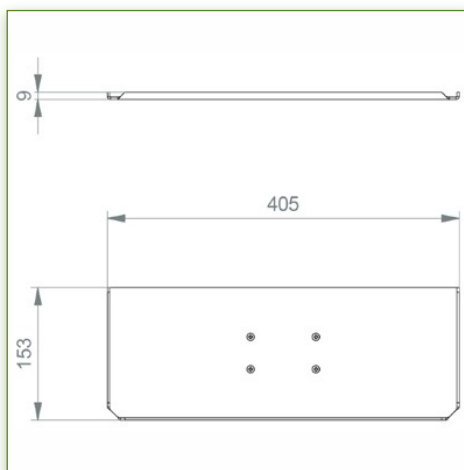
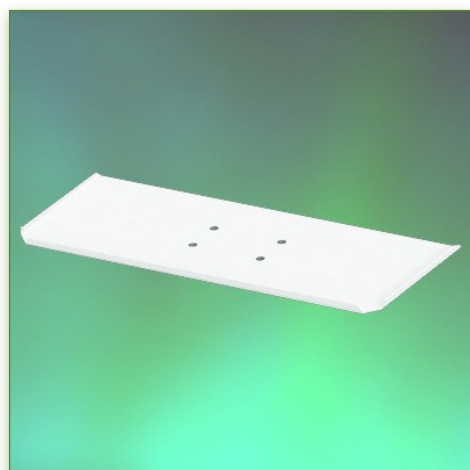

Anti-bacterial properties:

IT medical arms are now designed with Microban antibacterial protection, a revolutionary treatment that guarantees optimal hygiene. IT medical arms integrate Microban and other antibacterial agents into all medical products. It inhibits the growth of bacteria of all types. This is not a surface treatment. It is 100% in the totality of the product. It does not alter the physico-mechanical properties of the medical arm lift system. Simulations over 30 years show that 100% of the antibacterial properties are maintained. All medical articulated arms incorporate Microban. Microban is the world's leading provider of anti-bacterial solutions. It has been successfully applied for more than 35 years in a wide range of products used in the hospital, construction and food industries.

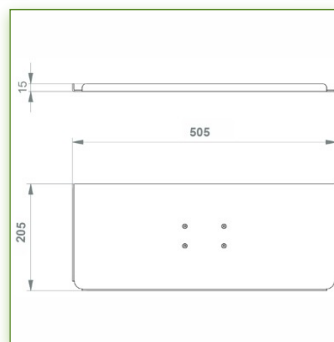
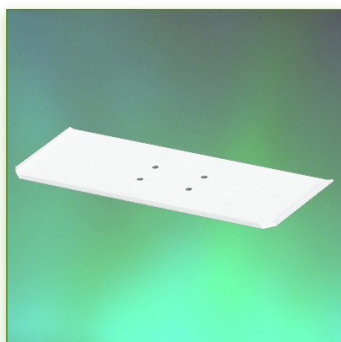
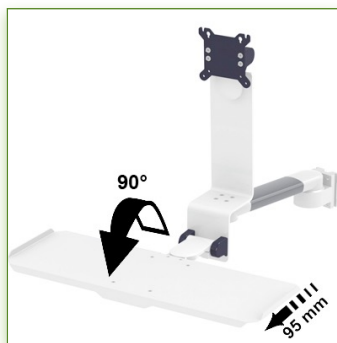
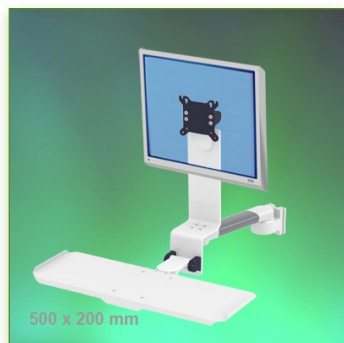

Display Compatibility: 26" Wide (Weight)
Supported Weight: 18 Kg
VESA standard: 75 / 100 mm
Keyboard-Mouse holder: 500 x 200 mm

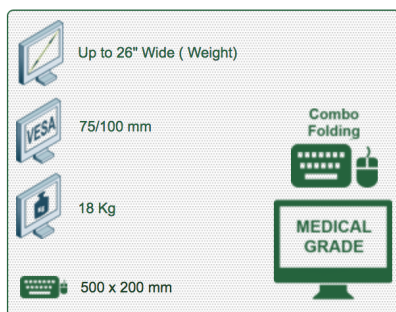

Do not hesitate to contact us if you have any questions about this product.

Warranty: 5 years

000.991.657-3

Graphite Grey and White

On Measure

= Depending on the elements

991.657-3

Medical Arm Combo Horizontal Foldable 240 mm for screen, keyboard and mouse, wall mounting on vertical sliding rail

This 240 mm Folding Combo Arm allows the LCD screen to be perfectly fixed, oriented and adjusted and supports the keyboard and mouse. It is coated with an anti-microbial agent offering hygiene and cleaning down to the last detail. Its modern design has been specially designed for healthcare environments.

Technical specifications:

- * Integrated cable channel
- * Optional Vertical Wall Slide Rail Mounting available in several lengths (480 mm - 720 mm - 960 mm - 1200 mm).
- * These wall rails can be easily cut to the required size. All cables also pass through the wall rail (See Options below)
- * This 240 mm Folding Combo Arm simply slides into the wall rail to adjust to the desired height and fixed.
- * It does not have height adjustment, but has two horizontal axes of rotation.
- * The head of this arm complies with the standard for mounting screens: VESA MIS-D 75 mm and 100 mm. * Tilt head.
- * Compatible with screens whose weight does not exceed 18 Kg.
- * Touch screen stability. * Screen tilt: 10°.
- * Screen rotation: 110° right, 110° left.
- * Arm rotation: 105° to the right, 105° to the left.
- * * Total length 660 - 755.5 mm
- * Foldable and removable keyboard and mouse holder: 500 x 200 mm
- * Compatible with multimedia terminals (TMM)
- * Color RAL 7024 (Graphite Grey) and White
- * All our medical arms are in conformity: CE, ROHS, Medical Grade, Regulations MDD 93/42 ECC.
- * Warranty: 5 years

Note: This arm can also be installed on one of our medical columns or trolleys.

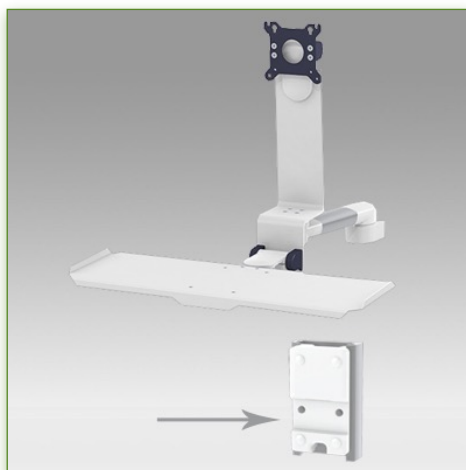
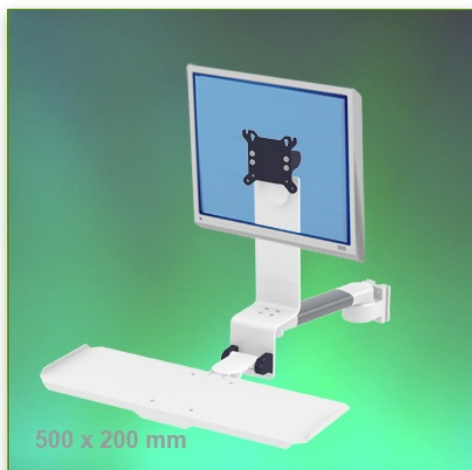

Display Compatibility: 26" Wide (Weight)
Supported Weight: 18 Kg
VESA standard: 75 / 100 mm
Keyboard-Mouse holder: 500 x 200 mm

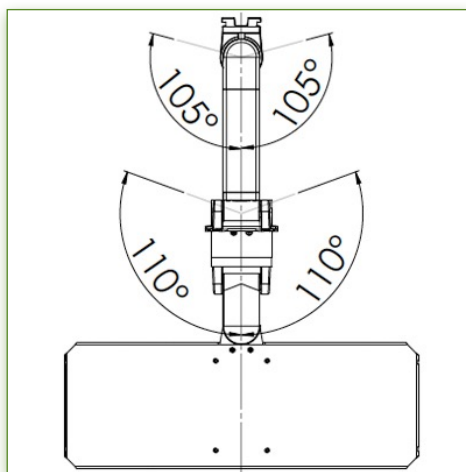
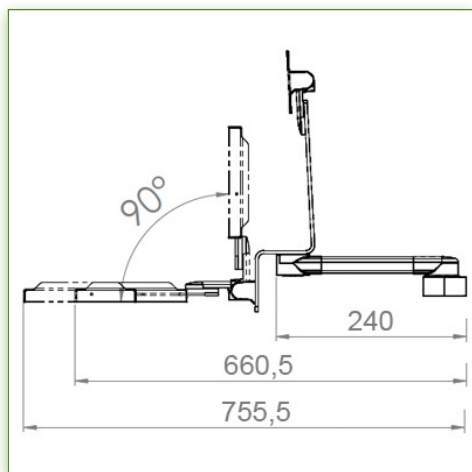
 Up to 26" Wide (Weight)
 75/100 mm
 18 Kg
 500 x 200 mm
MEDICAL GRADE

Do not hesitate to contact us if you have any questions about this product.

Warranty: 5 years

000.991.657-3

Graphite Grey and White

On Measure

= Depending on the elements

991.657-3

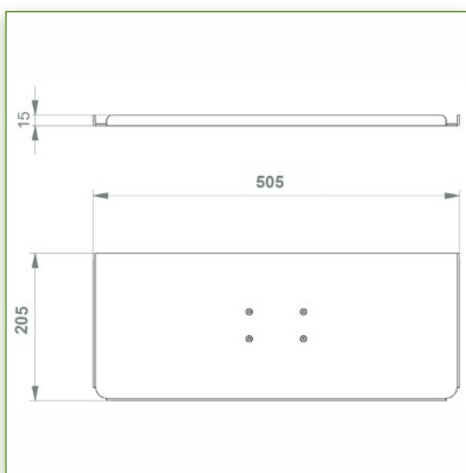

Anti-bacterial properties:

IT medical arms are now designed with Microban antibacterial protection, a revolutionary treatment that guarantees optimal hygiene. IT medical arms integrate Microban and other antibacterial agents into all medical products. It inhibits the growth of bacteria of all types. This is not a surface treatment. It is 100% in the totality of the product. It does not alter the physico-mechanical properties of the medical arm lift system. Simulations over 30 years show that 100% of the antibacterial properties are maintained. All medical articulated arms incorporate Microban. Microban is the world's leading provider of anti-bacterial solutions. It has been successfully applied for more than 35 years in a wide range of products used in the hospital, construction and food industries.

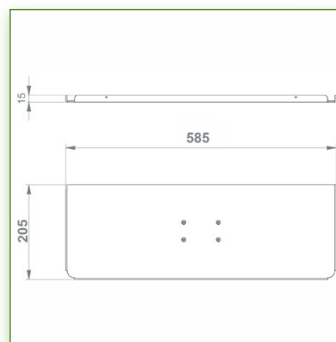
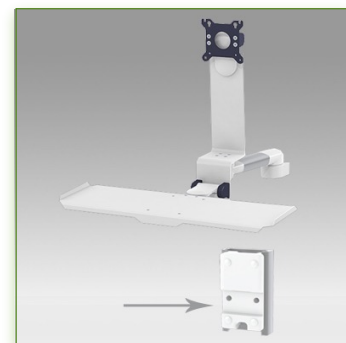
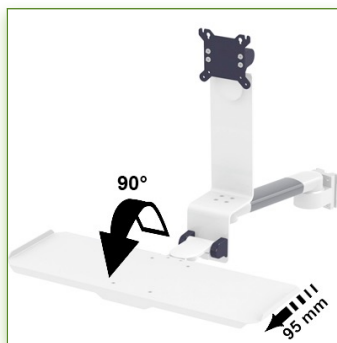

Display Compatibility: 26" Wide (Weight)
Supported Weight: 18 Kg
VESA standard: 75 / 100 mm
Keyboard-Mouse holder: 580 x 200 mm

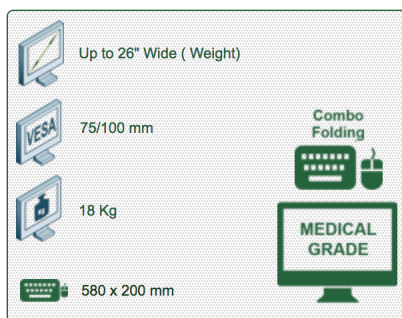

Do not hesitate to contact us if you have any questions about this product.

Warranty: 5 years

000.991.657-4

Graphite Grey and White

On Measure

= Depending on the elements

991.657-4

Medical Arm Combo Horizontal Foldable 240 mm for screen, keyboard and mouse, wall mounting on vertical sliding rail

This 240 mm Folding Combo Arm allows the LCD screen to be perfectly fixed, oriented and adjusted and supports the keyboard and mouse. It is coated with an anti-microbial agent offering hygiene and cleaning down to the last detail. Its modern design has been specially designed for healthcare environments.

Technical specifications:

- * Integrated cable channel
- * Optional Vertical Wall Slide Rail Mounting available in several lengths (480 mm - 720 mm - 960 mm - 1200 mm).
- * These wall rails can be easily cut to the required size. All cables also pass through the wall rail (See Options below)
- * This 240 mm Folding Combo Arm simply slides into the wall rail to adjust to the desired height and fixed.
- * It does not have height adjustment, but has two horizontal axes of rotation.
- * The head of this arm complies with the standard for mounting screens: VESA MIS-D 75 mm and 100 mm. * Tilt head.
- * Compatible with screens whose weight does not exceed 18 Kg.
- * Touch screen stability. * Screen tilt: 10°.
- * Screen rotation: 110° right, 110° left.
- * Arm rotation: 105° to the right, 105° to the left.
- * * Total length 660 - 755.5 mm
- * Foldable and removable keyboard and mouse holder: 580 x 200 mm
- * Compatible with multimedia terminals (TMM)
- * Color RAL 7024 (Graphite Grey) and White
- * All our medical arms are in conformity: CE, ROHS, Medical Grade, Regulations MDD 93/42 ECC.
- * Warranty: 5 years

Note: This arm can also be installed on one of our medical columns or trolleys.

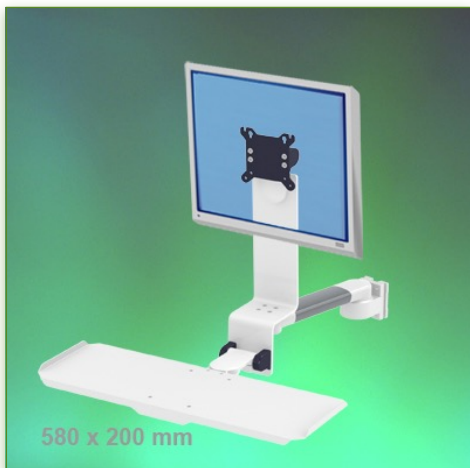

Display Compatibility: 26" Wide (Weight)
Supported Weight: 18 Kg
VESA standard: 75 / 100 mm
Keyboard-Mouse holder: 580 x 200 mm

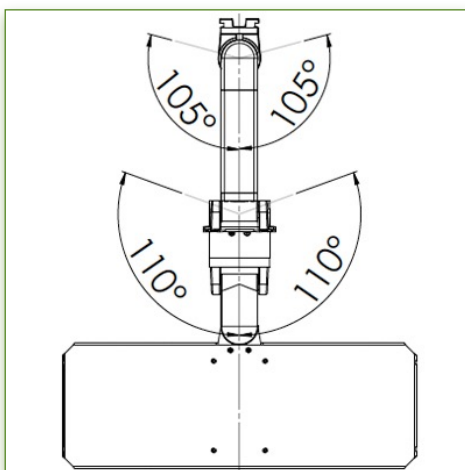
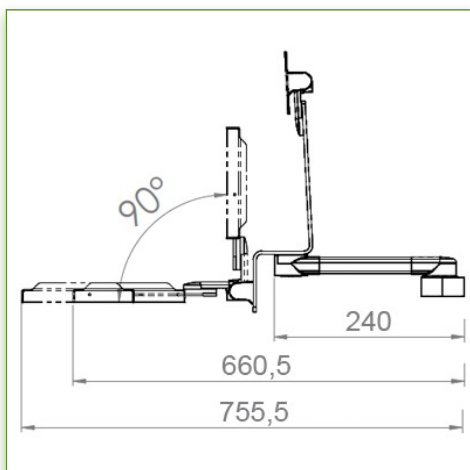
 Up to 26" Wide (Weight)
 75/100 mm
 18 Kg
 580 x 200 mm
Medical Grade

Do not hesitate to contact us if you have any questions about this product.

Warranty: 5 years

000.991.657-4

Graphite Grey and White

On Measure

= Depending on the elements

991.657-4

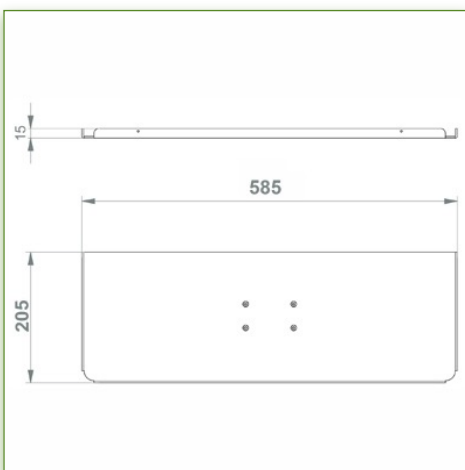
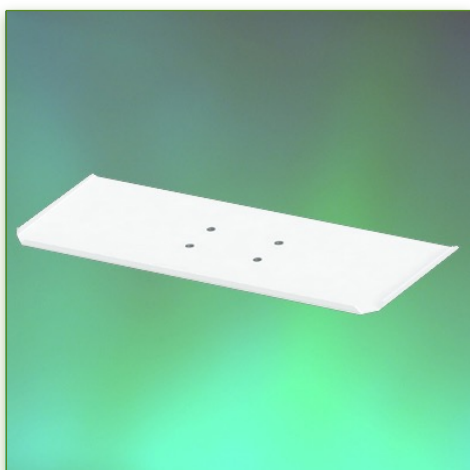

Anti-bacterial properties:

IT medical arms are now designed with Microban antibacterial protection, a revolutionary treatment that guarantees optimal hygiene. IT medical arms integrate Microban and other antibacterial agents into all medical products. It inhibits the growth of bacteria of all types. This is not a surface treatment. It is 100% in the totality of the product. It does not alter the physico-mechanical properties of the medical arm lift system. Simulations over 30 years show that 100% of the antibacterial properties are maintained. All medical articulated arms incorporate Microban. Microban is the world's leading provider of anti-bacterial solutions. It has been successfully applied for more than 35 years in a wide range of products used in the hospital, construction and food industries.

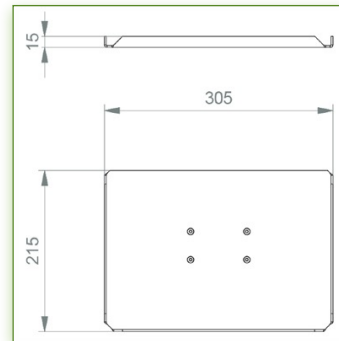
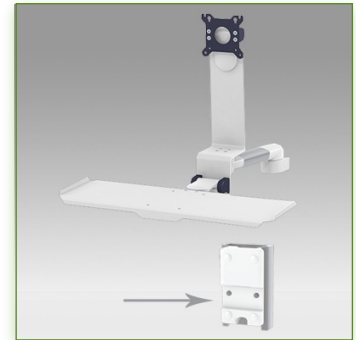
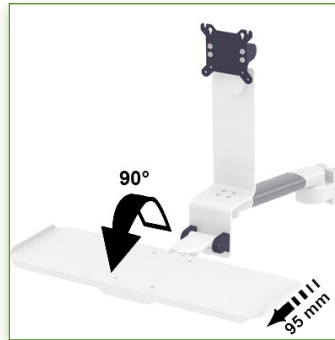
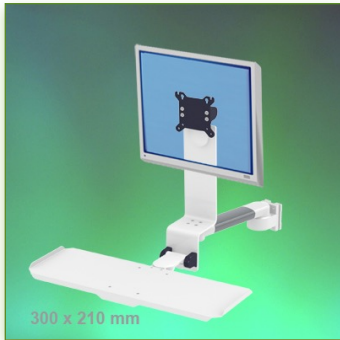

Display Compatibility: 26" Wide (Weight)
Supported Weight: 18 Kg
VESA standard: 75 / 100 mm
Keyboard-Mouse holder: 300 x 210 mm

 Up to 26" Wide (Weight)
 75/100 mm
 18 Kg
 300 x 210 mm
MEDICAL GRADE
Combo Folding

Do not hesitate to contact us if you have any questions about this product.

Warranty: 5 years

000.991.658-1

Graphite Grey and White

On Measure

= Depending on the elements

991.658-1

Medical Arm Combo Horizontal Foldable 300 mm for screen, keyboard and mouse, wall mounting on vertical sliding rail

This 300 mm Folding Combo Arm allows the LCD screen to be perfectly fixed, oriented and adjusted and supports the keyboard and mouse. It is coated with an anti-microbial agent offering hygiene and cleaning down to the last detail. Its modern design has been specially designed for healthcare environments.

Technical specifications:

- * Integrated cable channel
- * Optional Vertical Wall Slide Rail Mounting available in several lengths (480 mm - 720 mm - 960 mm - 1200 mm).
- * These wall rails can be easily cut to the required size. All cables also pass through the wall rail (See Options below)
- * This 300 mm Folding Combo Arm simply slides into the wall rail to adjust to the desired height and fixed.
- * It does not have height adjustment, but has two horizontal axes of rotation.
- * The head of this arm complies with the standard for mounting screens: VESA MIS-D 75 mm and 100 mm.
- * Tilt head.
- * Compatible with screens whose weight does not exceed 18 Kg.
- * Touch screen stability. * Screen tilt: 10°.
- * Screen rotation: 110° right, 110° left.
- * Arm rotation: 105° to the right, 105° to the left. * Total length 720 - 815 mm
- * Foldable and removable keyboard and mouse holder: 300 x 210 mm
- * Compatible with multimedia terminals (TMM)
- * Color RAL 7024 (Graphite Grey) and White
- * All our medical arms are in conformity: CE, ROHS, Medical Grade, Regulations MDD 93/42 ECC.
- * Warranty: 5 years

Note: This arm can also be installed on one of our medical columns or trolleys.

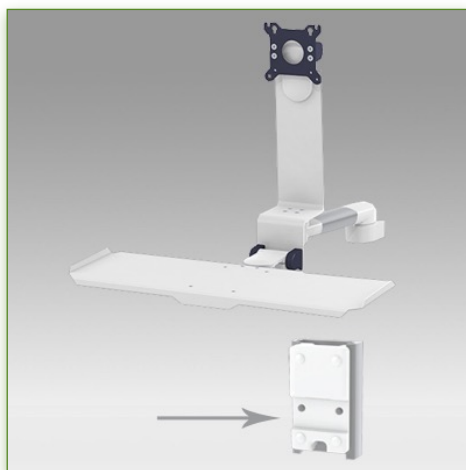
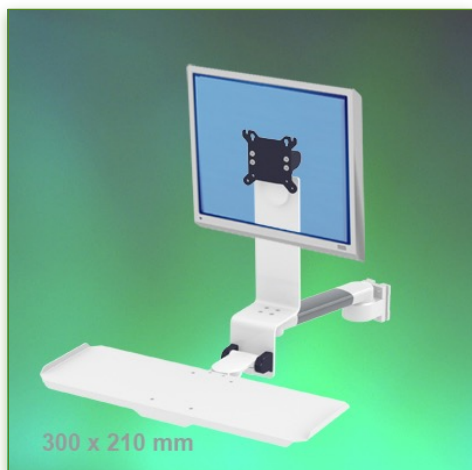

Display Compatibility: 26" Wide (Weight)
Supported Weight: 18 Kg
VESA standard: 75 / 100 mm
Keyboard-Mouse holder: 300 x 210 mm

Up to 26" Wide (Weight)
75/100 mm
18 Kg
300 x 210 mm

Combo Folding

MEDICAL GRADE

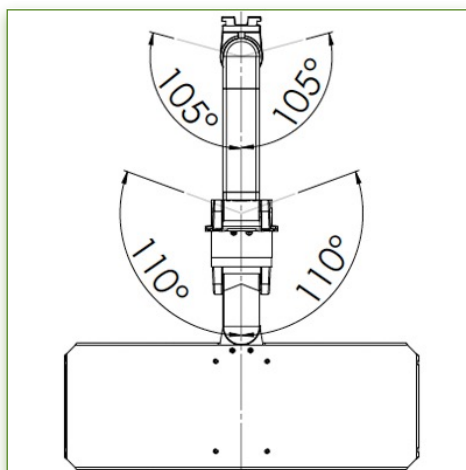
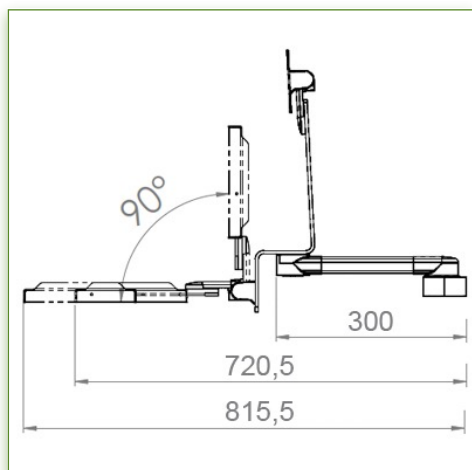

Do not hesitate to contact us if you have any questions about this product.

Warranty: 5 years

000.991.658-1

Graphite Grey and White

On Measure

= Depending on the elements

991.658-1

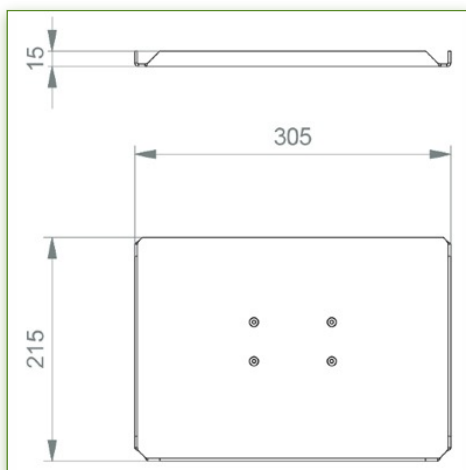

Anti-bacterial properties:

IT medical arms are now designed with Microban antibacterial protection, a revolutionary treatment that guarantees optimal hygiene. IT medical arms integrate Microban and other antibacterial agents into all medical products. It inhibits the growth of bacteria of all types. This is not a surface treatment. It is 100% in the totality of the product. It does not alter the physico-mechanical properties of the medical arm lift system. Simulations over 30 years show that 100% of the antibacterial properties are maintained. All medical articulated arms incorporate Microban. Microban is the world's leading provider of anti-bacterial solutions. It has been successfully applied for more than 35 years in a wide range of products used in the hospital, construction and food industries.

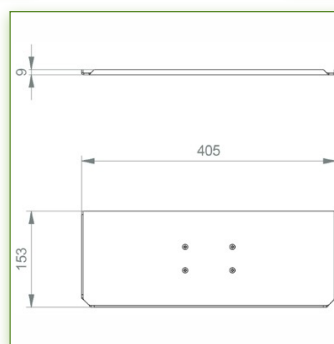
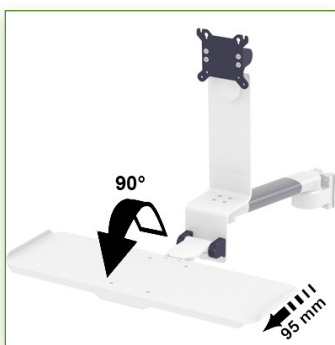
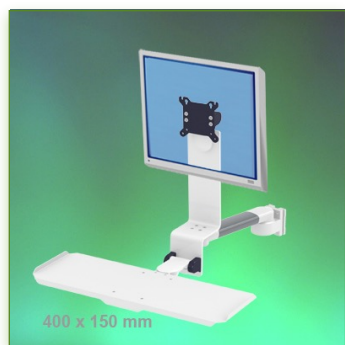

Display Compatibility: 26" Wide (Weight)
Supported Weight: 18 Kg
VESA standard: 75 / 100 mm
Keyboard-Mouse holder: 400 x 150 mm

Do not hesitate to contact us if you have any questions about this product.

Warranty: 5 years

000.991.658-2

Graphite Grey and White

On Measure

= Depending on the elements

991.658-2

Medical Arm Combo Horizontal Foldable 300 mm for screen, keyboard and mouse, wall mounting on vertical sliding rail

This 300 mm Folding Combo Arm allows the LCD screen to be perfectly fixed, oriented and adjusted and supports the keyboard and mouse. It is coated with an anti-microbial agent offering hygiene and cleaning down to the last detail. Its modern design has been specially designed for healthcare environments.

Technical specifications:

- * Integrated cable channel
- * Optional Vertical Wall Slide Rail Mounting available in several lengths (480 mm - 720 mm - 960 mm - 1200 mm).
- * These wall rails can be easily cut to the required size. All cables also pass through the wall rail (See Options below)
- * This 300 mm Folding Combo Arm simply slides into the wall rail to adjust to the desired height and fixed.
- * It does not have height adjustment, but has two horizontal axes of rotation.
- * The head of this arm complies with the standard for mounting screens: VESA MIS-D 75 mm and 100 mm.
- * Tilt head.
- * Compatible with screens whose weight does not exceed 18 Kg.
- * Touch screen stability. * Screen tilt: 10°.
- * Screen rotation: 110° right, 110° left.
- * Arm rotation: 105° to the right, 105° to the left. * Total length 720 - 815 mm
- * Foldable and removable keyboard and mouse holder: 400 x 150 mm
- * Compatible with multimedia terminals (TMM)
- * Color RAL 7024 (Graphite Grey) and White
- * All our medical arms are in conformity: CE, ROHS, Medical Grade, Regulations MDD 93/42 ECC.
- * Warranty: 5 years

Note: This arm can also be installed on one of our medical columns or trolleys.

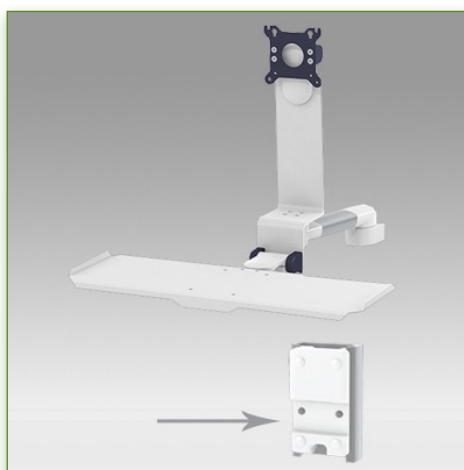
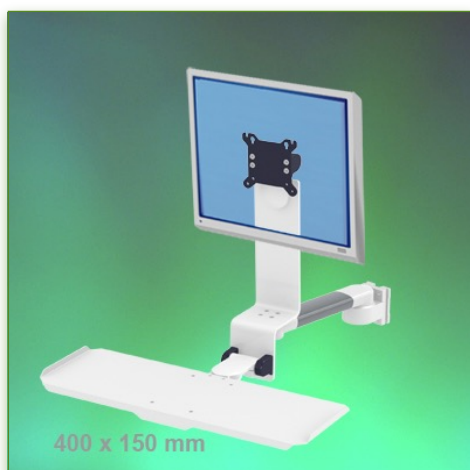

Display Compatibility: 26" Wide (Weight)
Supported Weight: 18 Kg
VESA standard: 75 / 100 mm
Keyboard-Mouse holder: 400 x 150 mm

Up to 26" Wide (Weight)
75/100 mm
18 Kg
400 x 150 mm

Combo Folding
MEDICAL GRADE

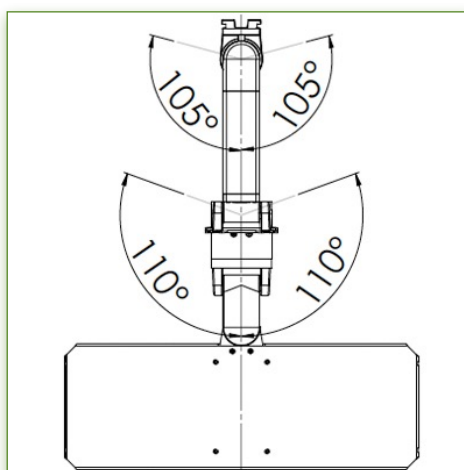
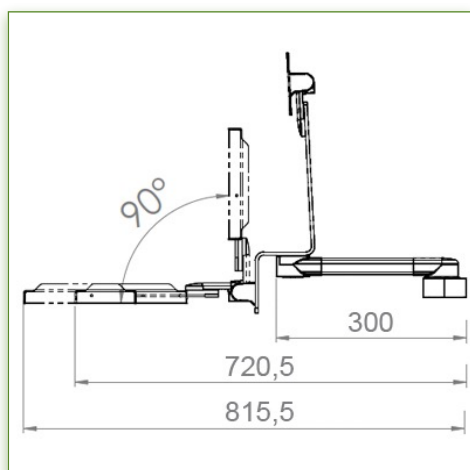

Do not hesitate to contact us if you have any questions about this product.



Warranty: 5 years



000.991.658-2



Graphite Grey and White



On Measure



= Depending on the elements



991.658-2

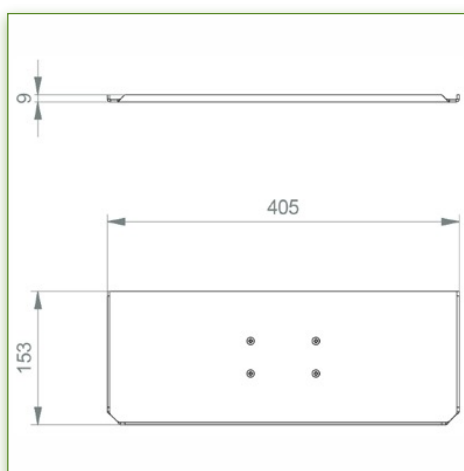

Anti-bacterial properties:

IT medical arms are now designed with Microban antibacterial protection, a revolutionary treatment that guarantees optimal hygiene. IT medical arms integrate Microban and other antibacterial agents into all medical products. It inhibits the growth of bacteria of all types. This is not a surface treatment. It is 100% in the totality of the product. It does not alter the physico-mechanical properties of the medical arm lift system. Simulations over 30 years show that 100% of the antibacterial properties are maintained. All medical articulated arms incorporate Microban. Microban is the world's leading provider of anti-bacterial solutions. It has been successfully applied for more than 35 years in a wide range of products used in the hospital, construction and food industries.

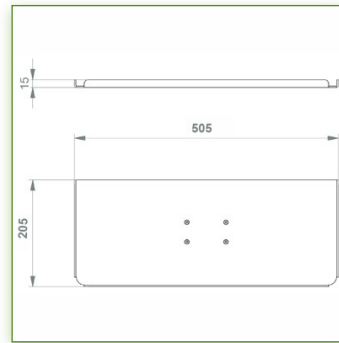
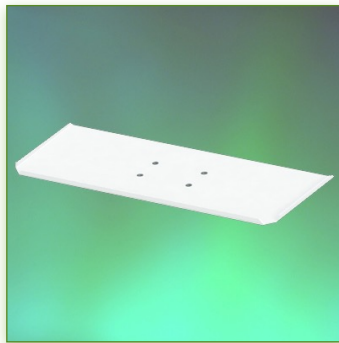
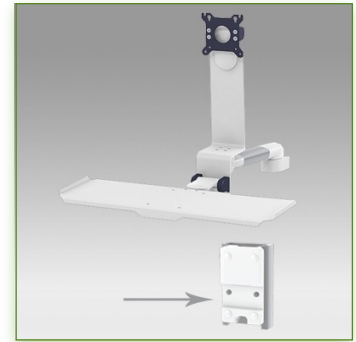
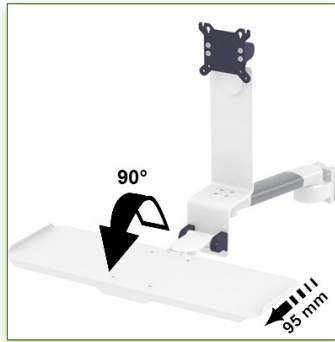
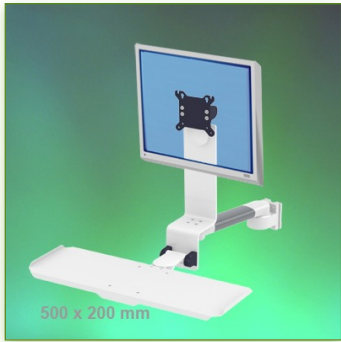

Display Compatibility: 26" Wide (Weight)
Supported Weight: 18 Kg
VESA standard: 75 / 100 mm
Keyboard-Mouse holder: 500 x 200 mm

Do not hesitate to contact us if you have any questions about this product.

Warranty: 5 years

000.991.658-3

Graphite Grey and White

On Measure

= Depending on the elements

991.658-3

Medical Arm Combo Horizontal Foldable 300 mm for screen, keyboard and mouse, wall mounting on vertical sliding rail

This 300 mm Folding Combo Arm allows the LCD screen to be perfectly fixed, oriented and adjusted and supports the keyboard and mouse. It is coated with an anti-microbial agent offering hygiene and cleaning down to the last detail. Its modern design has been specially designed for healthcare environments.

Technical specifications:

- * Integrated cable channel
- * Optional Vertical Wall Slide Rail Mounting available in several lengths (480 mm - 720 mm - 960 mm - 1200 mm).
- * These wall rails can be easily cut to the required size. All cables also pass through the wall rail (See Options below)
- * This 300 mm Folding Combo Arm simply slides into the wall rail to adjust to the desired height and fixed.
- * It does not have height adjustment, but has two horizontal axes of rotation.
- * The head of this arm complies with the standard for mounting screens: VESA MIS-D 75 mm and 100 mm.
- * Tilt head.
- * Compatible with screens whose weight does not exceed 18 Kg.
- * Touch screen stability. * Screen tilt: 10°.
- * Screen rotation: 110° right, 110° left.
- * Arm rotation: 105° to the right, 105° to the left. * Total length 720 - 815 mm
- * Foldable and removable keyboard and mouse holder: 500 x 200 mm
- * Compatible with multimedia terminals (TMM)
- * Color RAL 7024 (Graphite Grey) and White
- * All our medical arms are in conformity: CE, ROHS, Medical Grade, Regulations MDD 93/42 ECC.
- * Warranty: 5 years

Note: This arm can also be installed on one of our medical columns or trolleys.

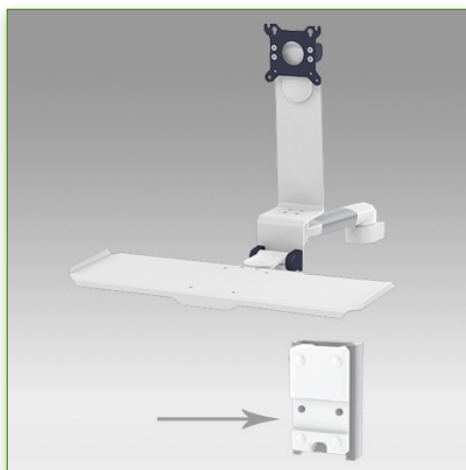

Display Compatibility: 26" Wide (Weight)
Supported Weight: 18 Kg
VESA standard: 75 / 100 mm
Keyboard-Mouse holder: 500 x 200 mm

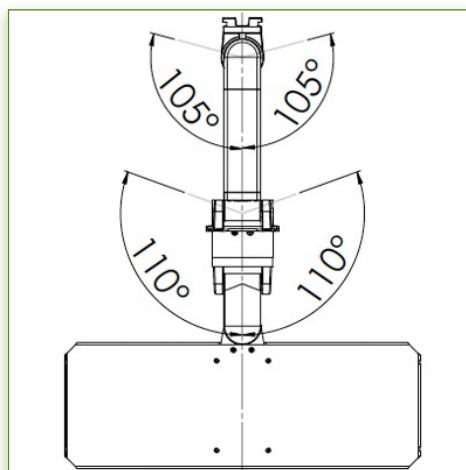
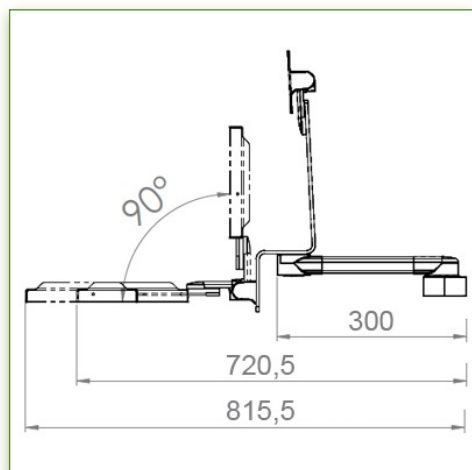
 Up to 26" Wide (Weight)
 75/100 mm
 18 Kg
 500 x 200 mm
MEDICAL GRADE
Combo Folding

Do not hesitate to contact us if you have any questions about this product.

Warranty: 5 years

000.991.658-3

Graphite Grey and White

On Measure

= Depending on the elements

991.658-3

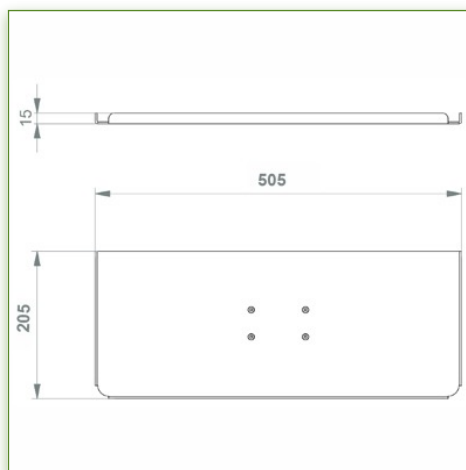
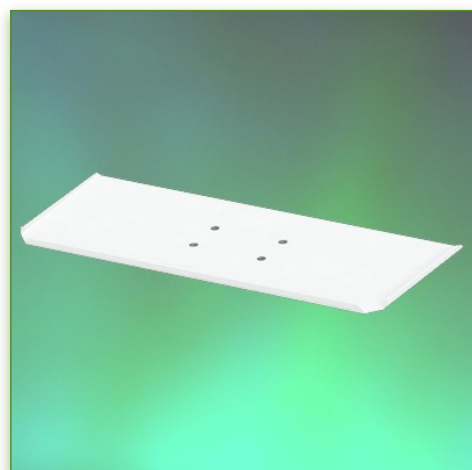

Anti-bacterial properties:

IT medical arms are now designed with Microban antibacterial protection, a revolutionary treatment that guarantees optimal hygiene. IT medical arms integrate Microban and other antibacterial agents into all medical products. It inhibits the growth of bacteria of all types. This is not a surface treatment. It is 100% in the totality of the product. It does not alter the physico-mechanical properties of the medical arm lift system. Simulations over 30 years show that 100% of the antibacterial properties are maintained. All medical articulated arms incorporate Microban. Microban is the world's leading provider of anti-bacterial solutions. It has been successfully applied for more than 35 years in a wide range of products used in the hospital, construction and food industries.

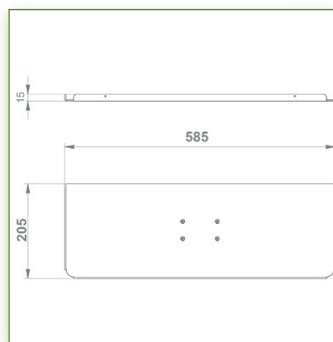
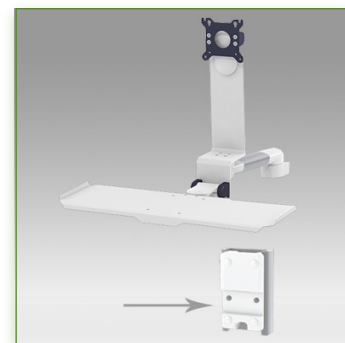
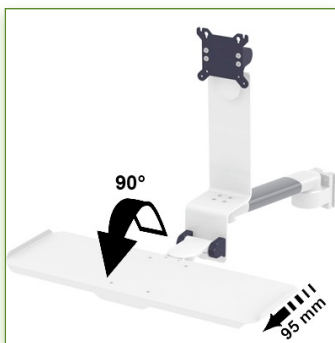
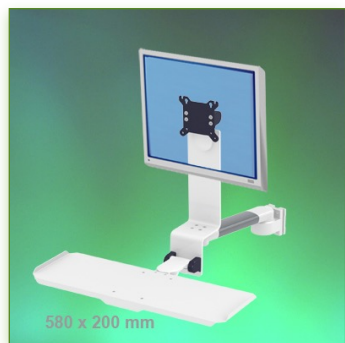

Display Compatibility: 26" Wide (Weight)
Supported Weight: 18 Kg
VESA standard: 75 / 100 mm
Keyboard-Mouse holder: 580 x 200 mm

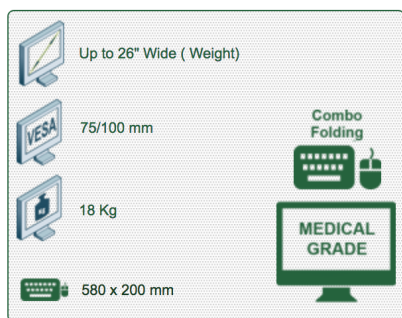

Do not hesitate to contact us if you have any questions about this product.

Warranty: 5 years

000.991.658-4

Graphite Grey and White

On Measure

= Depending on the elements

991.658-4

Medical Arm Combo Horizontal Foldable 300 mm for screen, keyboard and mouse, wall mounting on vertical sliding rail

This 300 mm Folding Combo Arm allows the LCD screen to be perfectly fixed, oriented and adjusted and supports the keyboard and mouse. It is coated with an anti-microbial agent offering hygiene and cleaning down to the last detail. Its modern design has been specially designed for healthcare environments.

Technical specifications:

- * Integrated cable channel
- * Optional Vertical Wall Slide Rail Mounting available in several lengths (480 mm - 720 mm - 960 mm - 1200 mm).
- * These wall rails can be easily cut to the required size. All cables also pass through the wall rail (See Options below)
- * This 300 mm Folding Combo Arm simply slides into the wall rail to adjust to the desired height and fixed.
- * It does not have height adjustment, but has two horizontal axes of rotation.
- * The head of this arm complies with the standard for mounting screens: VESA MIS-D 75 mm and 100 mm.
- * Tilt head.
- * Compatible with screens whose weight does not exceed 18 Kg.
- * Touch screen stability. * Screen tilt: 10°.
- * Screen rotation: 110° right, 110° left.
- * Arm rotation: 105° to the right, 105° to the left. * Total length 720 - 815 mm
- * Foldable and removable keyboard and mouse holder: 580 x 200 mm
- * Compatible with multimedia terminals (TMM)
- * Color RAL 7024 (Graphite Grey) and White
- * All our medical arms are in conformity: CE, ROHS, Medical Grade, Regulations MDD 93/42 ECC.
- * Warranty: 5 years

Note: This arm can also be installed on one of our medical columns or trolleys.

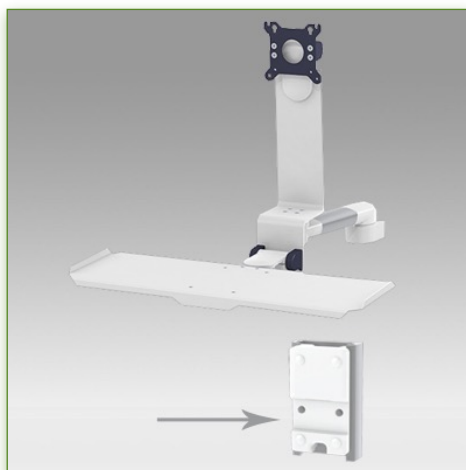

Display Compatibility: 26" Wide (Weight)
Supported Weight: 18 Kg
VESA standard: 75 / 100 mm
Keyboard-Mouse holder: 580 x 200 mm

Up to 26" Wide (Weight)
75/100 mm
18 Kg
580 x 200 mm

Combo Folding

MEDICAL GRADE

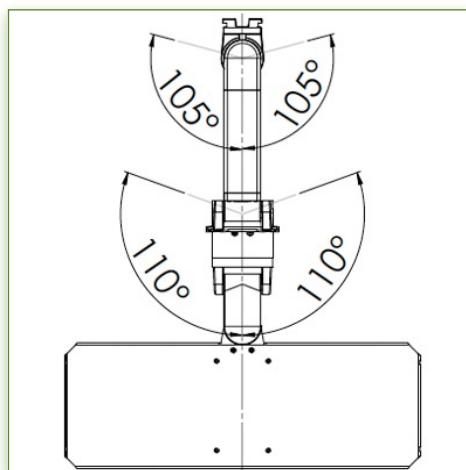
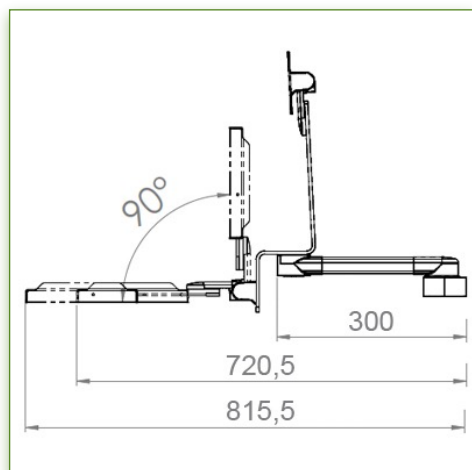

Do not hesitate to contact us if you have any questions about this product.

Warranty: 5 years

000.991.658-4

Graphite Grey and White

On Measure

= Depending on the elements

991.658-4

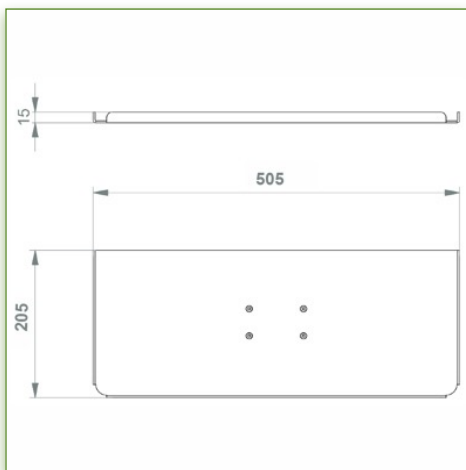
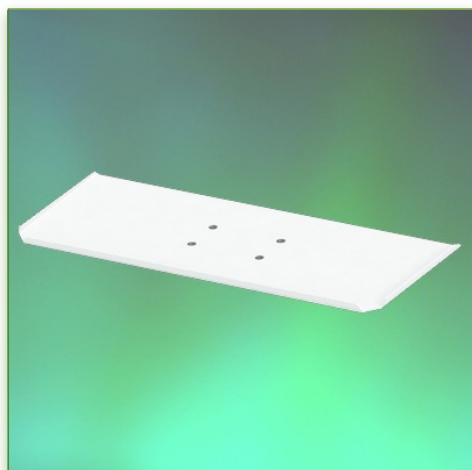

Anti-bacterial properties:

IT medical arms are now designed with Microban antibacterial protection, a revolutionary treatment that guarantees optimal hygiene. IT medical arms integrate Microban and other antibacterial agents into all medical products. It inhibits the growth of bacteria of all types. This is not a surface treatment. It is 100% in the totality of the product. It does not alter the physico-mechanical properties of the medical arm lift system. Simulations over 30 years show that 100% of the antibacterial properties are maintained. All medical articulated arms incorporate Microban. Microban is the world's leading provider of anti-bacterial solutions. It has been successfully applied for more than 35 years in a wide range of products used in the hospital, construction and food industries.

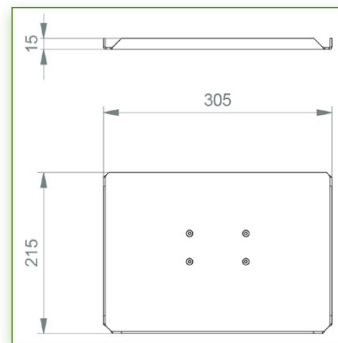
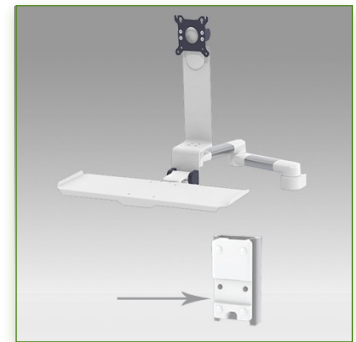
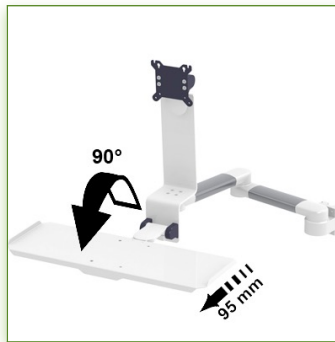
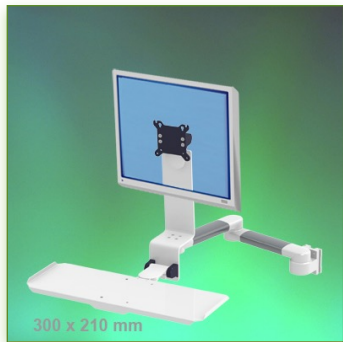

Display Compatibility: 26" Wide (Weight)
Supported Weight: 15 Kg
VESA standard: 75 / 100 mm
Keyboard-Mouse holder: 300 x 210 mm

 Up to 26" Wide (Weight)
 75/100 mm
 15 Kg
 300 x 210 mm
 MEDICAL GRADE
 Combo Folding

Do not hesitate to contact us if you have any questions about this product.

Warranty: 5 years

000.991.671-1

Graphite Grey and White

On Measure

= Depending on the elements

991.671-1

2 x 240 mm Foldable Horizontal Medical Combo Arm for screen, keyboard and mouse, wall mounting on vertical sliding rail

This 2 x 240 mm Folding Combo Arm allows the LCD screen to be perfectly fixed, oriented and adjusted and supports the keyboard and mouse. It is coated with an anti-microbial agent offering hygiene and cleaning down to the last detail. Its modern design has been specially designed for healthcare environments.

Technical specifications:

- * Integrated cable gland
- * Optional Vertical Wall Slide Rail Mounting available in several lengths (480 mm - 720 mm - 960 mm - 1200 mm).
- * These wall rails can be easily cut to the required size. All cables also pass through the wall rail. (See Options below)
- * This 2 x 240 mm Folding Combo Arm simply slides into the wall rail to adjust to the desired height and fixed.
- * It does not have height adjustment, but has three horizontal axes of rotation.
- * The head of this arm complies with the standard for mounting screens: VESA MIS-D 75 mm and 100 mm. Tilt head.
- * Compatible with screens whose weight does not exceed 15 Kg.
- * Touch screen stability. * Screen tilt: 10°.
- * Screen rotation: 110° right, 110° left.
- * Arm rotation: 105° to the right, 105° to the left.
- * Total length 1055 mm
- * Foldable and removable keyboard and mouse holder: 300 x 210 mm
- * Compatible with multimedia terminals (TMM)
- * Color RAL 7024 (Graphite Grey) and White
- * All our medical arms are in conformity: CE, ROHS, Medical Grade, Regulations MDD 93/42 ECC.
- * Warranty: 5 years

Note: This arm can also be installed on one of our medical columns or trolleys.

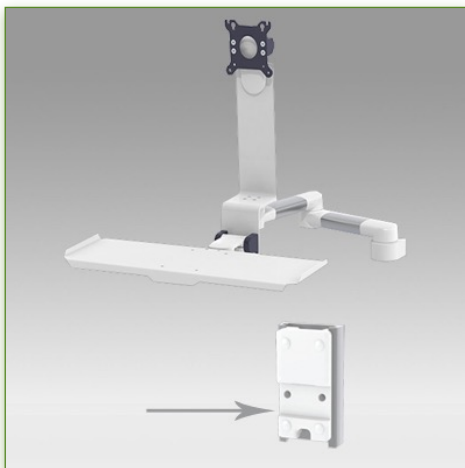

Display Compatibility: 26" Wide (Weight)
Supported Weight: 15 Kg
VESA standard: 75 / 100 mm
Keyboard-Mouse holder: 300 x 210 mm

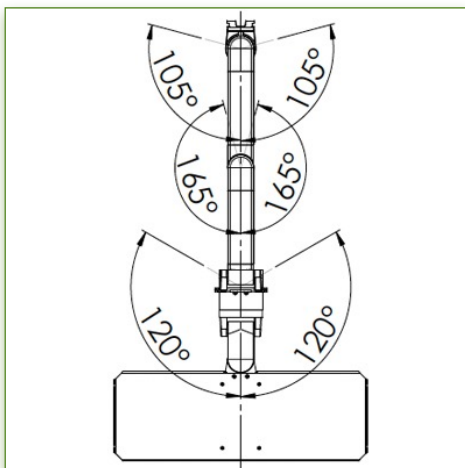
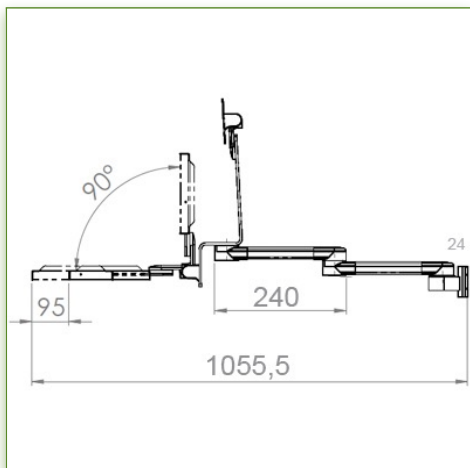
 Up to 26" Wide (Weight)
 75/100 mm
 15 Kg
 300 x 210 mm
Medical Grade

Do not hesitate to contact us if you have any questions about this product.

Warranty: 5 years

000.991.671-1

Graphite Grey and White

On Measure

= Depending on the elements

991.671-1

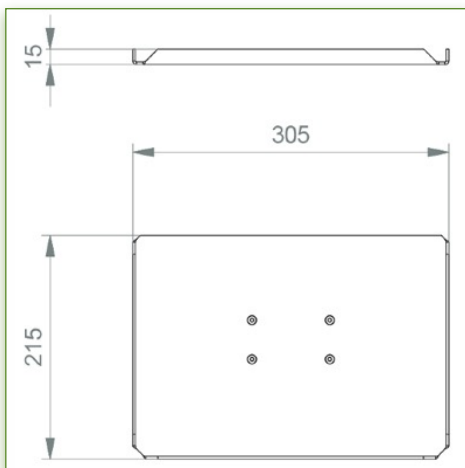

Anti-bacterial properties:

IT medical arms are now designed with Microban antibacterial protection, a revolutionary treatment that guarantees optimal hygiene. IT medical arms integrate Microban and other antibacterial agents into all medical products. It inhibits the growth of bacteria of all types. This is not a surface treatment. It is 100% in the totality of the product. It does not alter the physico-mechanical properties of the medical arm lift system. Simulations over 30 years show that 100% of the antibacterial properties are maintained. All medical articulated arms incorporate Microban. Microban is the world's leading provider of anti-bacterial solutions. It has been successfully applied for more than 35 years in a wide range of products used in the hospital, construction and food industries.

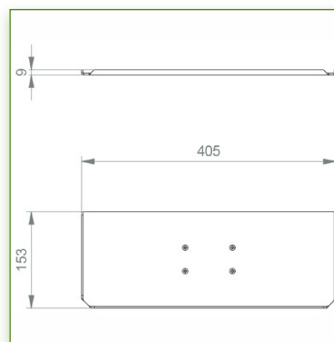
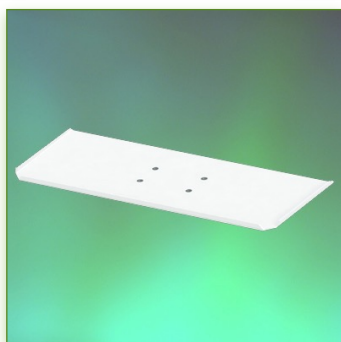
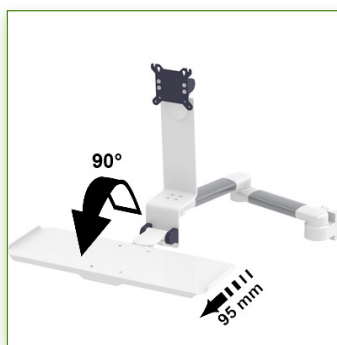
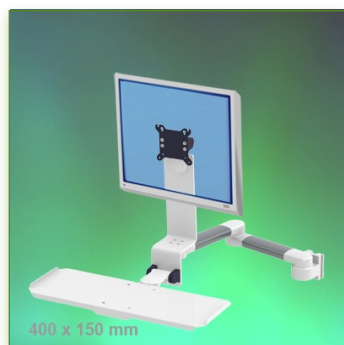

Display Compatibility: 26" Wide (Weight)
Supported Weight: 15 Kg
VESA standard: 75 / 100 mm
Keyboard-Mouse holder: 400 x 150 mm

 Up to 26" Wide (Weight)
 75/100 mm
 15 Kg
 400 x 150 mm
MEDICAL GRADE
Combo Folding

Do not hesitate to contact us if you have any questions about this product.

Warranty: 5 years

000.991.671-2

Graphite Grey and White

On Measure

= Depending on the elements

991.671-2

2 x 240 mm Foldable Horizontal Medical Combo Arm for screen, keyboard and mouse, wall mounting on vertical sliding rail

This 2 x 240 mm Folding Combo Arm allows the LCD screen to be perfectly fixed, oriented and adjusted and supports the keyboard and mouse. It is coated with an anti-microbial agent offering hygiene and cleaning down to the last detail. Its modern design has been specially designed for healthcare environments.

Technical specifications:

- * Integrated cable gland
- * Optional Vertical Wall Slide Rail Mounting available in several lengths (480 mm - 720 mm - 960 mm - 1200 mm).
- * These wall rails can be easily cut to the required size. All cables also pass through the wall rail. (See Options below)
- * This 2 x 240 mm Folding Combo Arm simply slides into the wall rail to adjust to the desired height and fixed.
- * It does not have height adjustment, but has three horizontal axes of rotation.
- * The head of this arm complies with the standard for mounting screens: VESA MIS-D 75 mm and 100 mm. Tilt head.
- * Compatible with screens whose weight does not exceed 15 Kg.
- * Touch screen stability. * Screen tilt: 10°.
- * Screen rotation: 110° right, 110° left.
- * Arm rotation: 105° to the right, 105° to the left.
- * Total length 1055 mm
- * Foldable and removable keyboard and mouse holder: 400 x 150 mm
- * Compatible with multimedia terminals (TMM)
- * Color RAL 7024 (Graphite Grey) and White
- * All our medical arms are in conformity: CE, ROHS, Medical Grade, Regulations MDD 93/42 ECC.
- * Warranty: 5 years

Note: This arm can also be installed on one of our medical columns or trolleys.

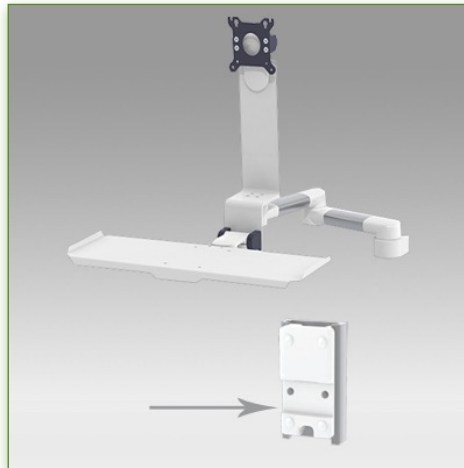
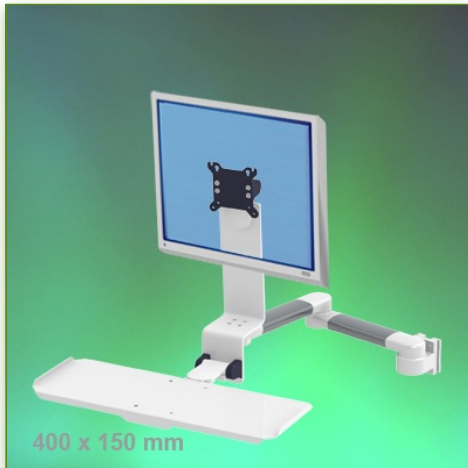

Display Compatibility: 26" Wide (Weight)
Supported Weight: 15 Kg
VESA standard: 75 / 100 mm
Keyboard-Mouse holder: 400 x 150 mm

Up to 26" Wide (Weight)
75/100 mm
15 Kg
400 x 150 mm
MEDICAL GRADE

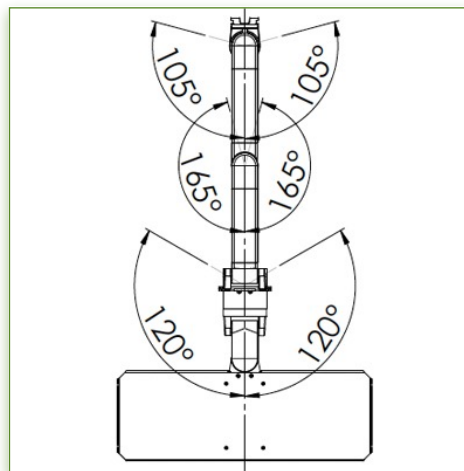
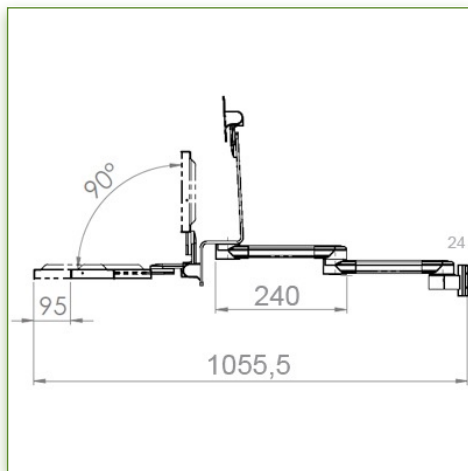

Do not hesitate to contact us if you have any questions about this product.

- Warranty: 5 years**
- 000.991.671-2**
- Graphite Grey and White**
- On Measure**
- = Depending on the elements**
- 991.671-2**

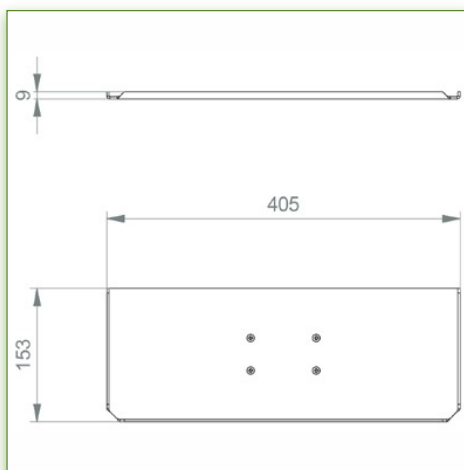
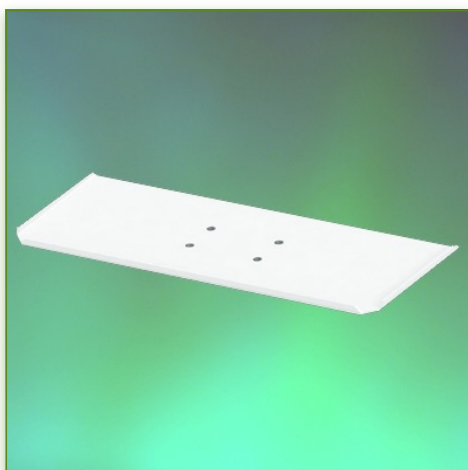

Anti-bacterial properties:

IT medical arms are now designed with Microban antibacterial protection, a revolutionary treatment that guarantees optimal hygiene. IT medical arms integrate Microban and other antibacterial agents into all medical products. It inhibits the growth of bacteria of all types. This is not a surface treatment. It is 100% in the totality of the product. It does not alter the physico-mechanical properties of the medical arm lift system. Simulations over 30 years show that 100% of the antibacterial properties are maintained. All medical articulated arms incorporate Microban. Microban is the world's leading provider of anti-bacterial solutions. It has been successfully applied for more than 35 years in a wide range of products used in the hospital, construction and food industries.

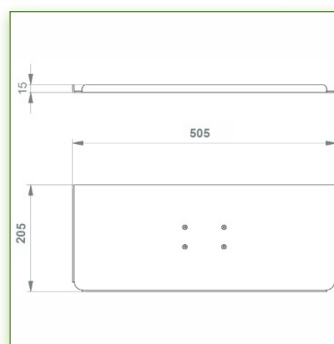
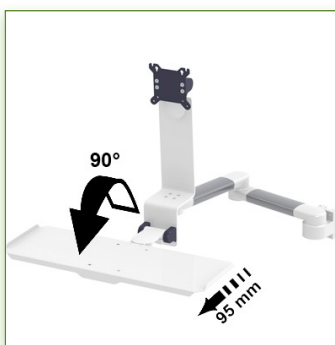

Display Compatibility: 26" Wide (Weight)
Supported Weight: 15 Kg
VESA standard: 75 / 100 mm
Keyboard-Mouse holder: 500 x 200 mm

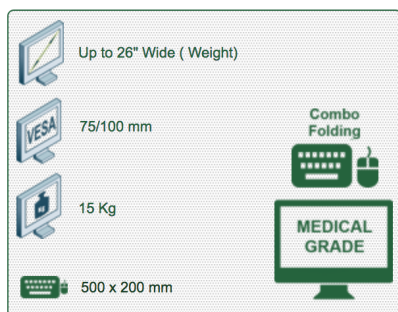

Do not hesitate to contact us if you have any questions about this product.



Warranty: 5 years



000.991.671-3



Graphite Grey and White



On Measure



= Depending on the elements



991.671-3

2 x 240 mm Foldable Horizontal Medical Combo Arm for screen, keyboard and mouse, wall mounting on vertical sliding rail

This 2 x 240 mm Folding Combo Arm allows the LCD screen to be perfectly fixed, oriented and adjusted and supports the keyboard and mouse. It is coated with an anti-microbial agent offering hygiene and cleaning down to the last detail. Its modern design has been specially designed for healthcare environments.

Technical specifications:

- * Integrated cable gland
- * Optional Vertical Wall Slide Rail Mounting available in several lengths (480 mm - 720 mm - 960 mm - 1200 mm).
- * These wall rails can be easily cut to the required size. All cables also pass through the wall rail. (See Options below)
- * This 2 x 240 mm Folding Combo Arm simply slides into the wall rail to adjust to the desired height and fixed.
- * It does not have height adjustment, but has three horizontal axes of rotation.
- * The head of this arm complies with the standard for mounting screens: VESA MIS-D 75 mm and 100 mm. Tilt head.
- * Compatible with screens whose weight does not exceed 15 Kg.
- * Touch screen stability. * Screen tilt: 10°.
- * Screen rotation: 110° right, 110° left.
- * Arm rotation: 105° to the right, 105° to the left.
- * Total length 1055 mm
- * Foldable and removable keyboard and mouse holder: 500 x 200 mm
- * Compatible with multimedia terminals (TMM)
- * Color RAL 7024 (Graphite Grey) and White
- * All our medical arms are in conformity: CE, ROHS, Medical Grade, Regulations MDD 93/42 ECC.
- * Warranty: 5 years

Note: This arm can also be installed on one of our medical columns or trolleys.

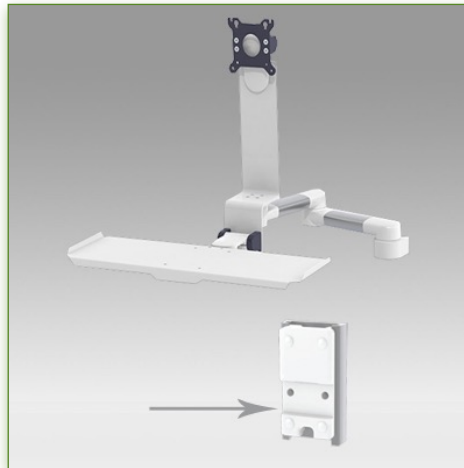
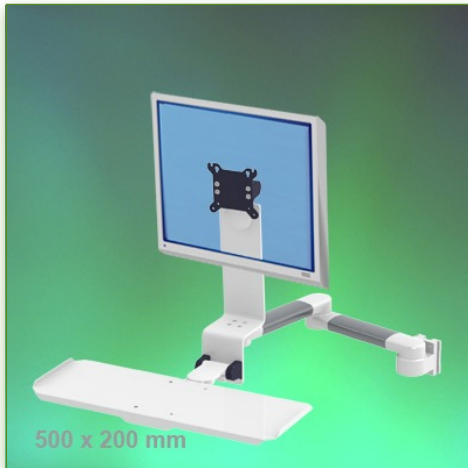

Display Compatibility: 26" Wide (Weight)
Supported Weight: 15 Kg
VESA standard: 75 / 100 mm
Keyboard-Mouse holder: 500 x 200 mm

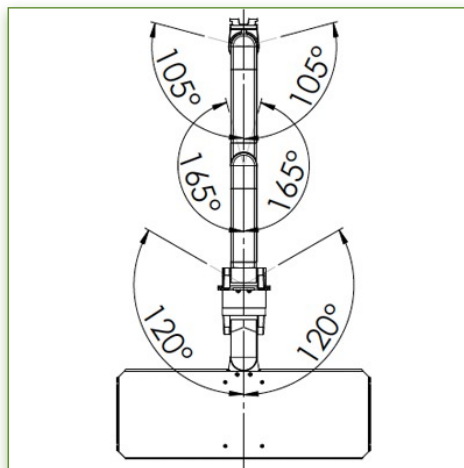
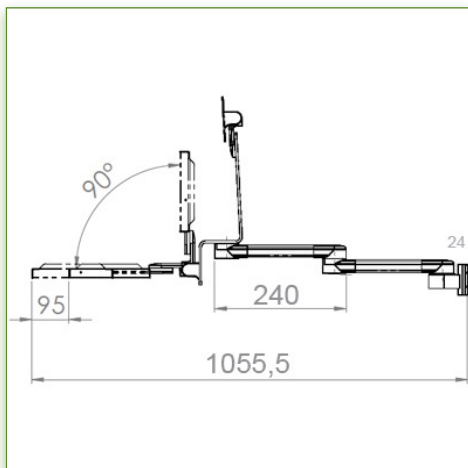
 Up to 26" Wide (Weight)
 75/100 mm
 15 Kg
 500 x 200 mm
MEDICAL GRADE
Combo Folding

Do not hesitate to contact us if you have any questions about this product.

- Warranty: 5 years**
- 000.991.671-3
- Graphite Grey and White**
- On Measure**
- = Depending on the elements**
- 991.671-3**

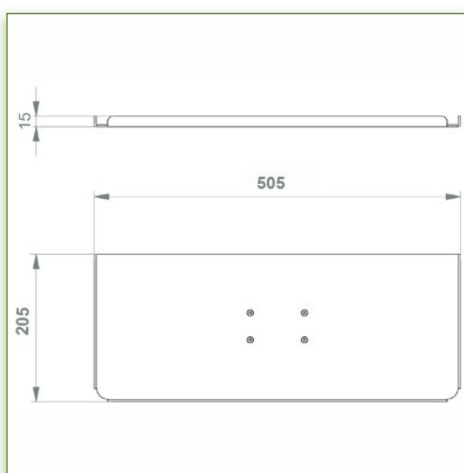
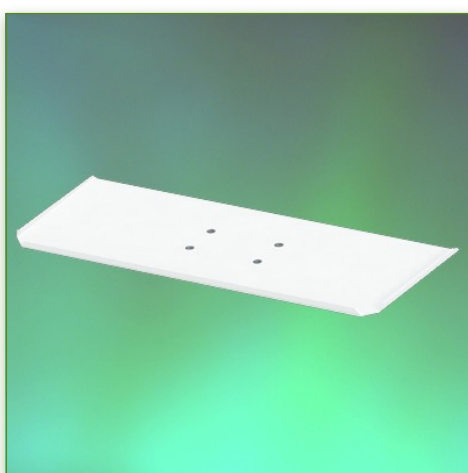

Anti-bacterial properties:

IT medical arms are now designed with Microban antibacterial protection, a revolutionary treatment that guarantees optimal hygiene. IT medical arms integrate Microban and other antibacterial agents into all medical products. It inhibits the growth of bacteria of all types. This is not a surface treatment. It is 100% in the totality of the product. It does not alter the physico-mechanical properties of the medical arm lift system. Simulations over 30 years show that 100% of the antibacterial properties are maintained. All medical articulated arms incorporate Microban. Microban is the world's leading provider of anti-bacterial solutions. It has been successfully applied for more than 35 years in a wide range of products used in the hospital, construction and food industries.

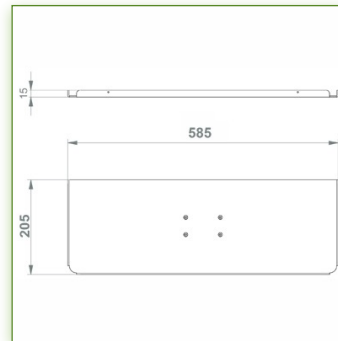
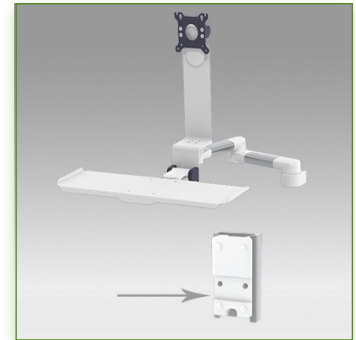
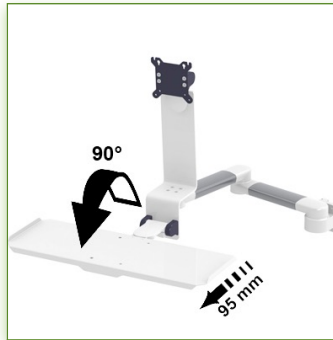

Display Compatibility: 26" Wide (Weight)
Supported Weight: 15 Kg
VESA standard: 75 / 100 mm
Keyboard-Mouse holder: 580 x 200 mm

 Up to 26" Wide (Weight)
 75/100 mm
 15 Kg
 580 x 200 mm
 MEDICAL GRADE
 Combo Folding

2 x 240 mm Foldable Horizontal Medical Combo Arm for screen, keyboard and mouse, wall mounting on vertical sliding rail

This 2 x 240 mm Folding Combo Arm allows the LCD screen to be perfectly fixed, oriented and adjusted and supports the keyboard and mouse. It is coated with an anti-microbial agent offering hygiene and cleaning down to the last detail. Its modern design has been specially designed for healthcare environments.

Technical specifications:

- * Integrated cable gland
- * Optional Vertical Wall Slide Rail Mounting available in several lengths (480 mm - 720 mm - 960 mm - 1200 mm).
- * These wall rails can be easily cut to the required size. All cables also pass through the wall rail. (See Options below)
- * This 2 x 240 mm Folding Combo Arm simply slides into the wall rail to adjust to the desired height and fixed.
- * It does not have height adjustment, but has three horizontal axes of rotation.
- * The head of this arm complies with the standard for mounting screens: VESA MIS-D 75 mm and 100 mm. Tilt head.
- * Compatible with screens whose weight does not exceed 15 Kg.
- * Touch screen stability. * Screen tilt: 10°.
- * Screen rotation: 110° right, 110° left.
- * Arm rotation: 105° to the right, 105° to the left.
- * Total length 1055 mm
- * Foldable and removable keyboard and mouse holder: 580 x 200 mm
- * Compatible with multimedia terminals (TMM)
- * Color RAL 7024 (Graphite Grey) and White
- * All our medical arms are in conformity: CE, ROHS, Medical Grade, Regulations MDD 93/42 ECC.
- * Warranty: 5 years

Note: This arm can also be installed on one of our medical columns or trolleys.

Do not hesitate to contact us if you have any questions about this product.

Warranty: 5 years

000.991.671-4

Graphite Grey and White

On Measure

= Depending on the elements

991.671-4

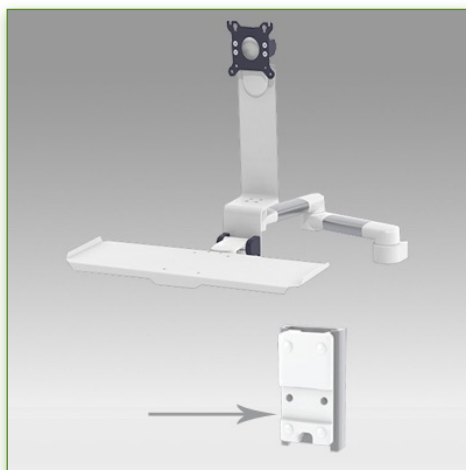

Display Compatibility: 26" Wide (Weight)
Supported Weight: 15 Kg
VESA standard: 75 / 100 mm
Keyboard-Mouse holder: 580 x 200 mm

Up to 26" Wide (Weight)
75/100 mm
15 Kg
580 x 200 mm

Combo Folding

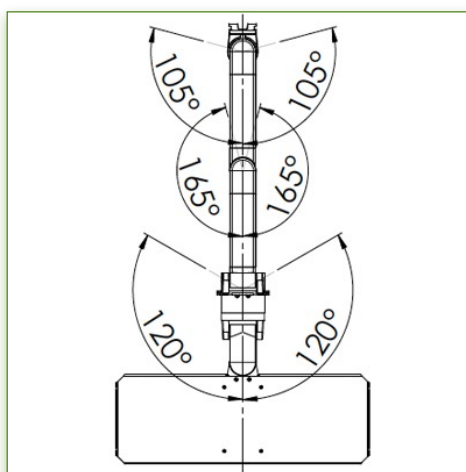
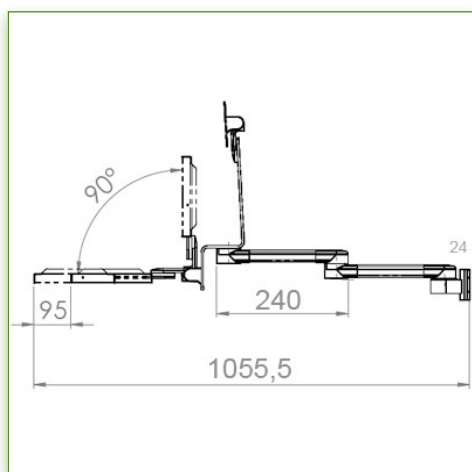

Do not hesitate to contact us if you have any questions about this product.

- Warranty: 5 years**
- 000.991.671-4**
- Graphite Grey and White**
- On Measure**
- = Depending on the elements**
- 991.671-4**

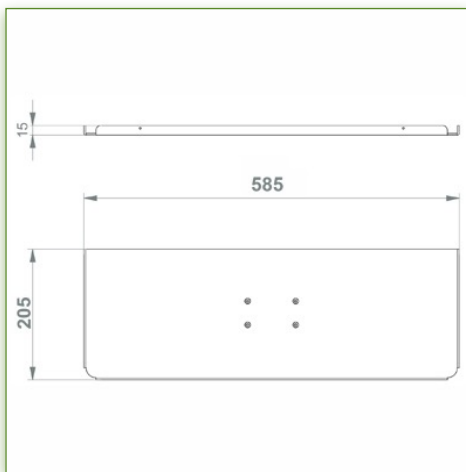

Anti-bacterial properties:

IT medical arms are now designed with Microban antibacterial protection, a revolutionary treatment that guarantees optimal hygiene. IT medical arms integrate Microban and other antibacterial agents into all medical products. It inhibits the growth of bacteria of all types. This is not a surface treatment. It is 100% in the totality of the product. It does not alter the physico-mechanical properties of the medical arm lift system. Simulations over 30 years show that 100% of the antibacterial properties are maintained. All medical articulated arms incorporate Microban. Microban is the world's leading provider of anti-bacterial solutions. It has been successfully applied for more than 35 years in a wide range of products used in the hospital, construction and food industries.

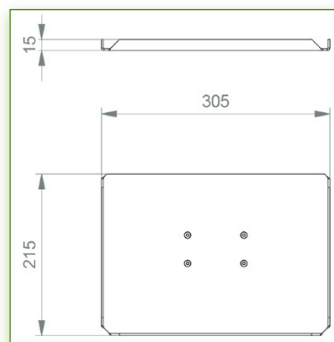
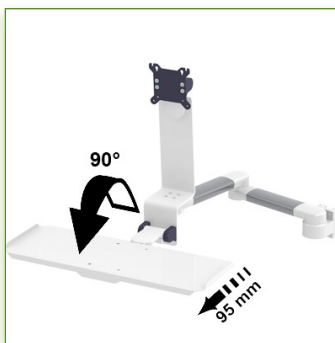

Display Compatibility: 26" Wide (Weight)
Supported Weight: 12,5 Kg
VESA standard: 75 / 100 mm
Keyboard-Mouse holder: 300 x 210 mm

Do not hesitate to contact us if you have any questions about this product.

Warranty: 5 years

000.991.672-1

Graphite Grey and White

On Measure

= Depending on the elements

991.672-1

2 x 300 mm Foldable Horizontal Medical Combo Arm for screen, keyboard and mouse, wall mounting on vertical sliding rail

This 2 x 300 mm Folding Combo Arm allows the LCD screen to be perfectly fixed, oriented and adjusted and supports the keyboard and mouse. It is coated with an anti-microbial agent offering hygiene and cleaning down to the last detail. Its modern design has been specially designed for healthcare environments.

Technical specifications:

- * Integrated cable gland
- * Optional Vertical Wall Slide Rail Mounting available in several lengths (480 mm - 720 mm - 960 mm - 1200 mm).
- * These wall rails can be easily cut to the required size. All cables also pass through the wall rail. (See Options below)
- * This 2 x 300 mm Folding Combo Arm simply slides into the wall rail to adjust to the desired height and fixed.
- * It does not have height adjustment, but has three horizontal axes of rotation.
- * The head of this arm complies with the standard for mounting screens: VESA MIS-D 75 mm and 100 mm. Tilt head.
- * Compatible with screens whose weight does not exceed 12,5 Kg.
- * Touch screen stability. * Screen tilt: 10°.
- * Screen rotation: 110° right, 110° left.
- * Arm rotation: 105° to the right, 105° to the left. * Total length 1115 mm
- * Foldable and removable keyboard and mouse holder: 300 x 210 mm
- * Compatible with multimedia terminals (TMM)
- * Color RAL 7024 (Graphite Grey) and White
- * All our medical arms are in conformity: CE, ROHS, Medical Grade, Regulations MDD 93/42 ECC.
- * Warranty: 5 years

Note: This arm can also be installed on one of our medical columns or trolleys

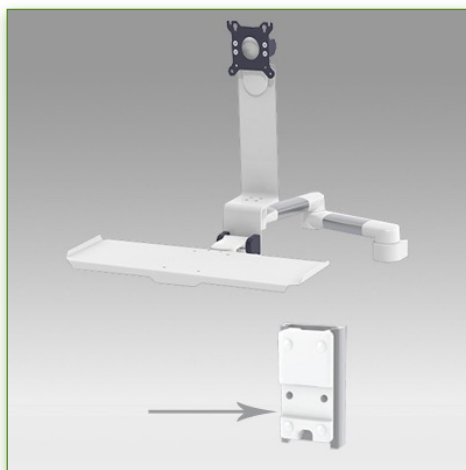
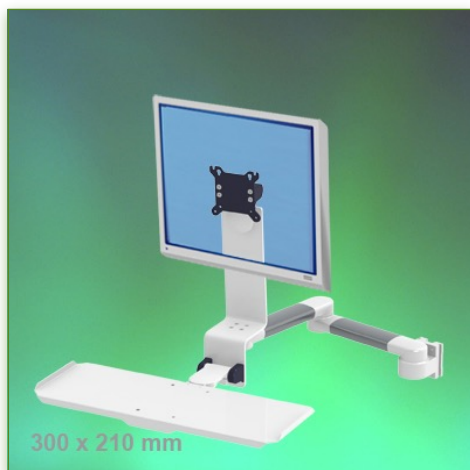

Display Compatibility: 26" Wide (Weight)
Supported Weight: 12,5 Kg
VESA standard: 75 / 100 mm
Keyboard-Mouse holder: 300 x 210 mm

Up to 26" Wide (Weight)
75/100 mm
12,5 Kg
300 x 210 mm

Combo Folding

MEDICAL GRADE

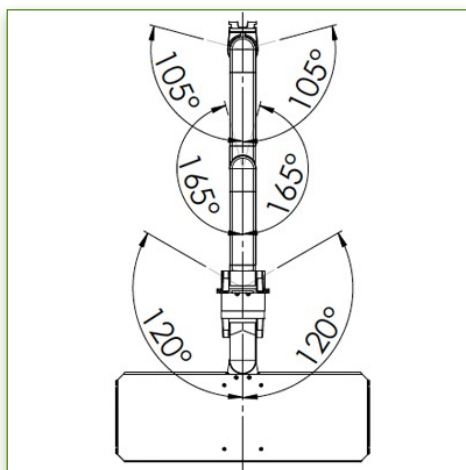
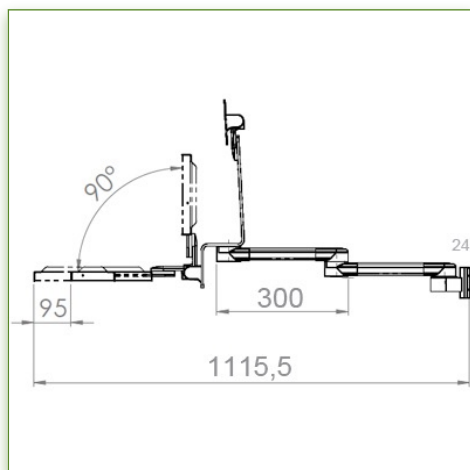

Do not hesitate to contact us if you have any questions about this product.

Warranty: 5 years

000.991.672-1

Graphite Grey and White

On Measure

= Depending on the elements

991.672-1

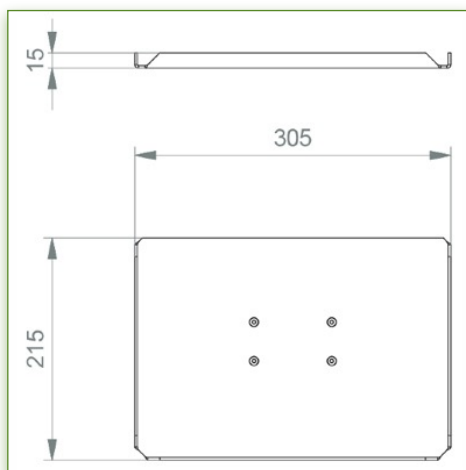

Anti-bacterial properties:

IT medical arms are now designed with Microban antibacterial protection, a revolutionary treatment that guarantees optimal hygiene. IT medical arms integrate Microban and other antibacterial agents into all medical products. It inhibits the growth of bacteria of all types. This is not a surface treatment. It is 100% in the totality of the product. It does not alter the physico-mechanical properties of the medical arm lift system. Simulations over 30 years show that 100% of the antibacterial properties are maintained. All medical articulated arms incorporate Microban. Microban is the world's leading provider of anti-bacterial solutions. It has been successfully applied for more than 35 years in a wide range of products used in the hospital, construction and food industries.

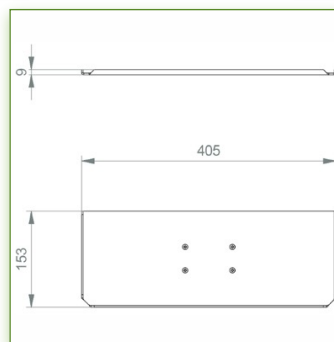
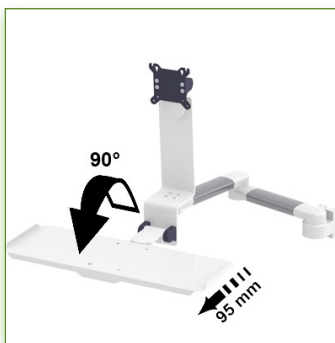

Display Compatibility: 26" Wide (Weight)
Supported Weight: 12,5 Kg
VESA standard: 75 / 100 mm
Keyboard-Mouse holder: 400 x 150 mm

Do not hesitate to contact us if you have any questions about this product.

Warranty: 5 years

000.991.672-2

Graphite Grey and White

On Measure

= Depending on the elements

991.672-2

2 x 300 mm Foldable Horizontal Medical Combo Arm for screen, keyboard and mouse, wall mounting on vertical sliding rail

This 2 x 300 mm Folding Combo Arm allows the LCD screen to be perfectly fixed, oriented and adjusted and supports the keyboard and mouse. It is coated with an anti-microbial agent offering hygiene and cleaning down to the last detail. Its modern design has been specially designed for healthcare environments.

Technical specifications:

- * Integrated cable gland
- * Optional Vertical Wall Slide Rail Mounting available in several lengths (480 mm - 720 mm - 960 mm - 1200 mm).
- * These wall rails can be easily cut to the required size. All cables also pass through the wall rail. (See Options below)
- * This 2 x 300 mm Folding Combo Arm simply slides into the wall rail to adjust to the desired height and fixed.
- * It does not have height adjustment, but has three horizontal axes of rotation.
- * The head of this arm complies with the standard for mounting screens: VESA MIS-D 75 mm and 100 mm. Tilt head.
- * Compatible with screens whose weight does not exceed 12,5 Kg.
- * Touch screen stability. * Screen tilt: 10°.
- * Screen rotation: 110° right, 110° left.
- * Arm rotation: 105° to the right, 105° to the left. * Total length 1115 mm
- * Foldable and removable keyboard and mouse holder: 400 x 150 mm
- * Compatible with multimedia terminals (TMM)
- * Color RAL 7024 (Graphite Grey) and White
- * All our medical arms are in conformity: CE, ROHS, Medical Grade, Regulations MDD 93/42 ECC.
- * Warranty: 5 years

Note: This arm can also be installed on one of our medical columns or trolleys

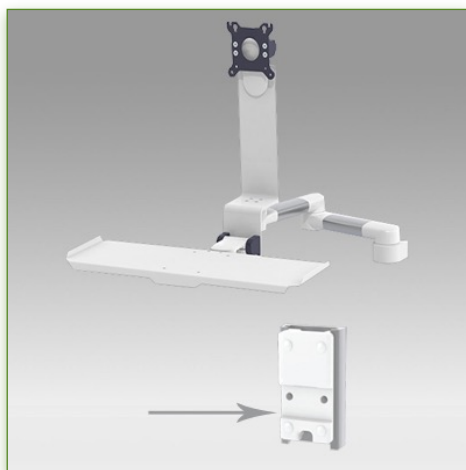
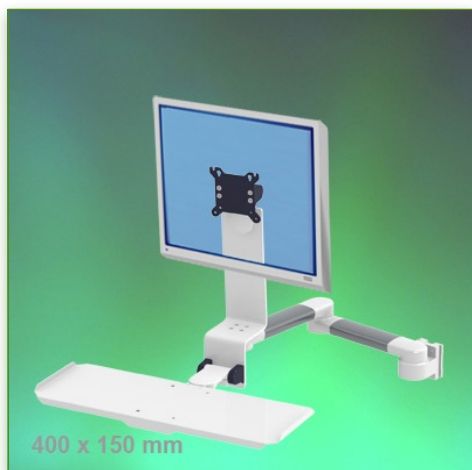

Display Compatibility: 26" Wide (Weight)
Supported Weight: 12,5 Kg
VESA standard: 75 / 100 mm
Keyboard-Mouse holder: 400 x 150 mm

Up to 26" Wide (Weight)
75/100 mm
12,5 Kg
400 x 150 mm
MEDICAL GRADE

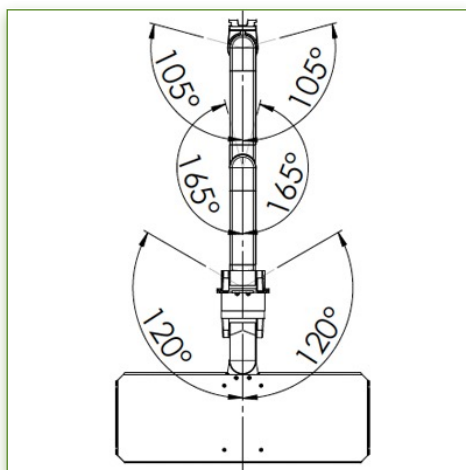
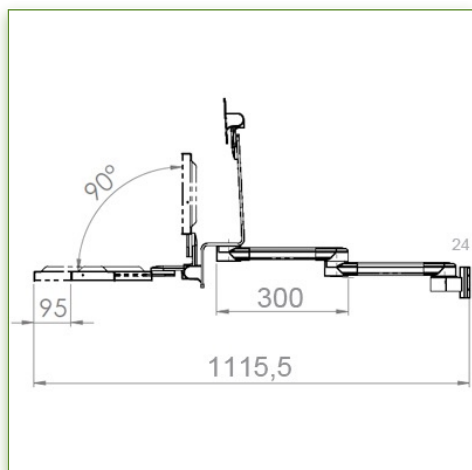

Do not hesitate to contact us if you have any questions about this product.

Warranty: 5 years

000.991.672-2

Graphite Grey and White

On Measure

= Depending on the elements

991.672-2

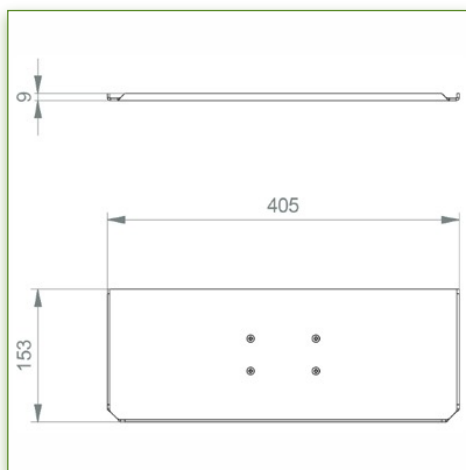
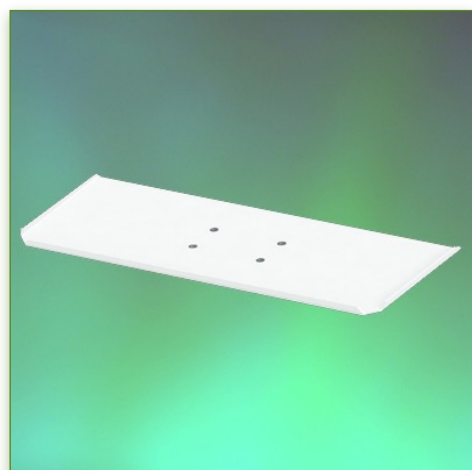

Anti-bacterial properties:

IT medical arms are now designed with Microban antibacterial protection, a revolutionary treatment that guarantees optimal hygiene. IT medical arms integrate Microban and other antibacterial agents into all medical products. It inhibits the growth of bacteria of all types. This is not a surface treatment. It is 100% in the totality of the product. It does not alter the physico-mechanical properties of the medical arm lift system. Simulations over 30 years show that 100% of the antibacterial properties are maintained. All medical articulated arms incorporate Microban. Microban is the world's leading provider of anti-bacterial solutions. It has been successfully applied for more than 35 years in a wide range of products used in the hospital, construction and food industries.

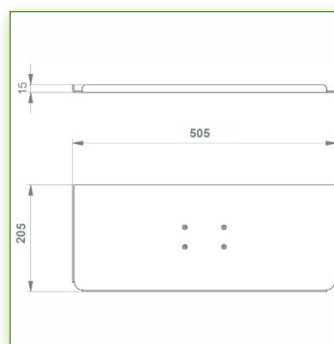
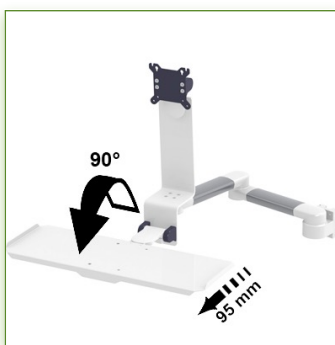
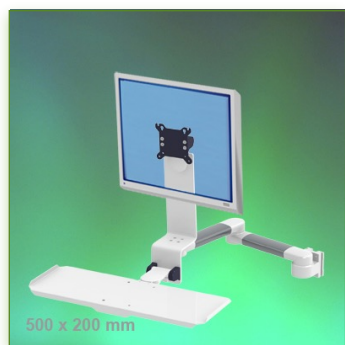

Display Compatibility: 26" Wide (Weight)
Supported Weight: 12,5 Kg
VESA standard: 75 / 100 mm
Keyboard-Mouse holder: 500 x 200 mm

Do not hesitate to contact us if you have any questions about this product.

Warranty: 5 years

000.991.672-3

Graphite Grey and White

On Measure

= Depending on the elements

991.672-3

2 x 300 mm Foldable Horizontal Medical Combo Arm for screen, keyboard and mouse, wall mounting on vertical sliding rail

This 2 x 300 mm Folding Combo Arm allows the LCD screen to be perfectly fixed, oriented and adjusted and supports the keyboard and mouse. It is coated with an anti-microbial agent offering hygiene and cleaning down to the last detail. Its modern design has been specially designed for healthcare environments.

Technical specifications:

- * Integrated cable gland
- * Optional Vertical Wall Slide Rail Mounting available in several lengths (480 mm - 720 mm - 960 mm - 1200 mm).
- * These wall rails can be easily cut to the required size. All cables also pass through the wall rail. (See Options below)
- * This 2 x 300 mm Folding Combo Arm simply slides into the wall rail to adjust to the desired height and fixed.
- * It does not have height adjustment, but has three horizontal axes of rotation.
- * The head of this arm complies with the standard for mounting screens: VESA MIS-D 75 mm and 100 mm. Tilt head.
- * Compatible with screens whose weight does not exceed 12,5 Kg.
- * Touch screen stability. * Screen tilt: 10°.
- * Screen rotation: 110° right, 110° left.
- * Arm rotation: 105° to the right, 105° to the left. * Total length 1115 mm
- * Foldable and removable keyboard and mouse holder: 500 x 200 mm
- * Compatible with multimedia terminals (TMM)
- * Color RAL 7024 (Graphite Grey) and White
- * All our medical arms are in conformity: CE, ROHS, Medical Grade, Regulations MDD 93/42 ECC.
- * Warranty: 5 years

Note: This arm can also be installed on one of our medical columns or trolleys

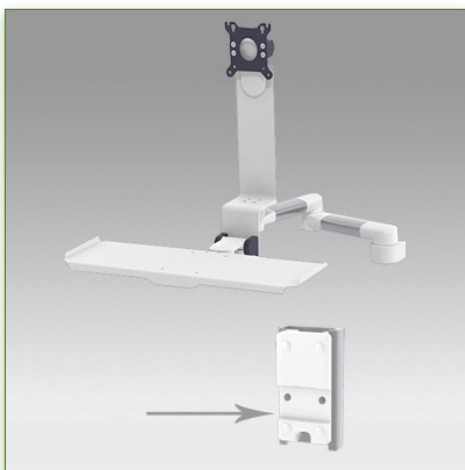
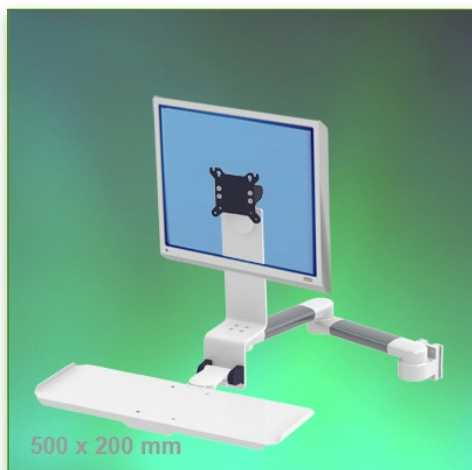

Display Compatibility: 26" Wide (Weight)
 Supported Weight: 12,5 Kg
 VESA standard: 75 / 100 mm
 Keyboard-Mouse holder: 500 x 200 mm

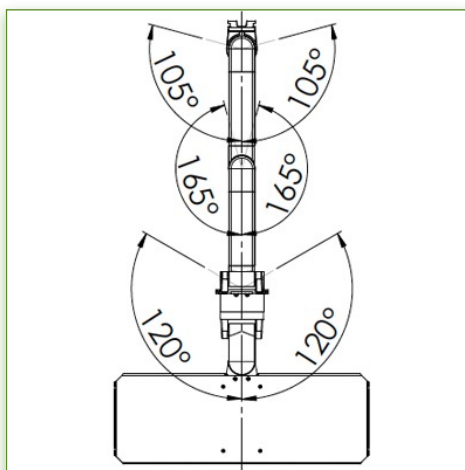
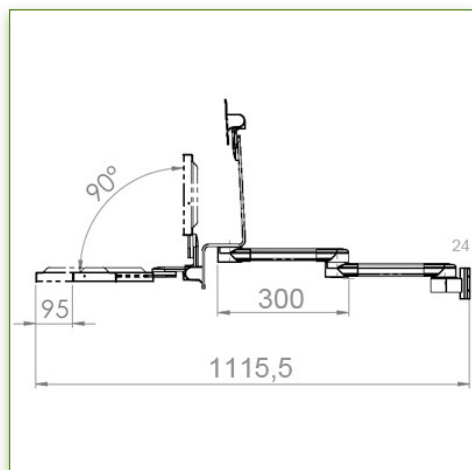
 Up to 26" Wide (Weight)
 75/100 mm
 12,5 Kg
 500 x 200 mm
MEDICAL GRADE
Combo Folding

Do not hesitate to contact us if you have any questions about this product.

Warranty: 5 years

000.991.672-3

Graphite Grey and White

On Measure

= Depending on the elements

991.672-3

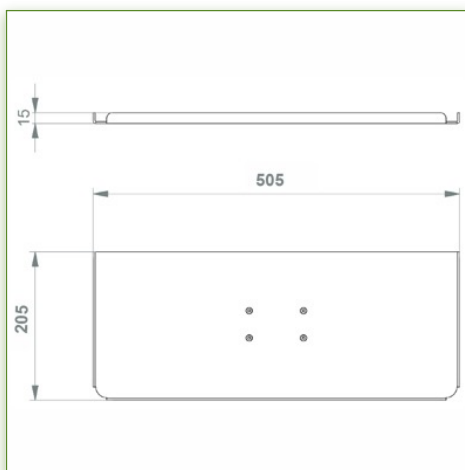
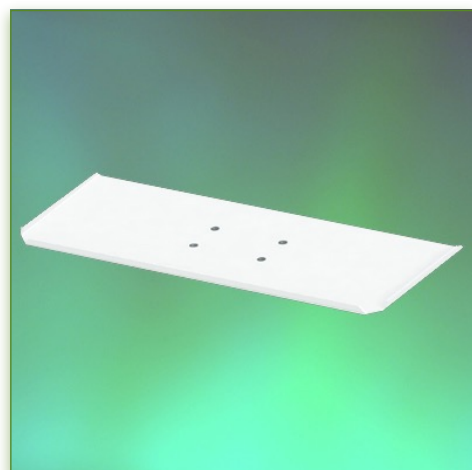

Anti-bacterial properties:

IT medical arms are now designed with Microban antibacterial protection, a revolutionary treatment that guarantees optimal hygiene. IT medical arms integrate Microban and other antibacterial agents into all medical products. It inhibits the growth of bacteria of all types. This is not a surface treatment.

It is 100% in the totality of the product. It does not alter the physico-mechanical properties of the medical arm lift system. Simulations over 30 years show that 100% of the antibacterial properties are maintained.

All medical articulated arms incorporate Microban. Microban is the world's leading provider of anti-bacterial solutions. It has been successfully applied for more than 35 years in a wide range of products used in the hospital, construction and food industries.

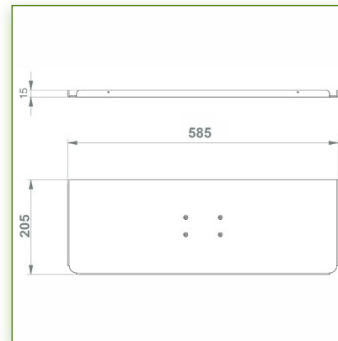
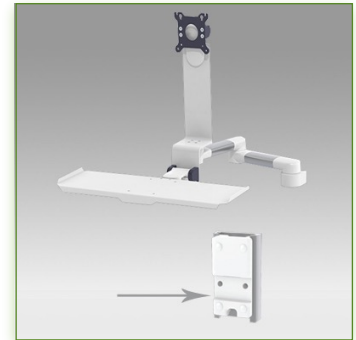
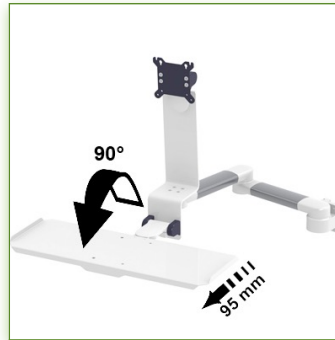
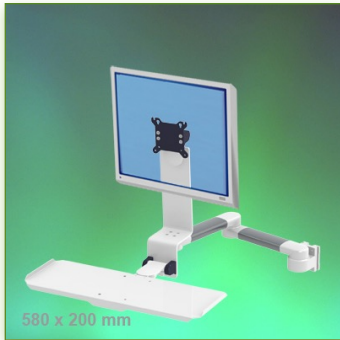

Display Compatibility: 26" Wide (Weight)
Supported Weight: 12,5 Kg
VESA standard: 75 / 100 mm
Keyboard-Mouse holder: 580 x 200 mm

2 x 300 mm Foldable Horizontal Medical Combo Arm for screen, keyboard and mouse, wall mounting on vertical sliding rail

This 2 x 300 mm Folding Combo Arm allows the LCD screen to be perfectly fixed, oriented and adjusted and supports the keyboard and mouse. It is coated with an anti-microbial agent offering hygiene and cleaning down to the last detail. Its modern design has been specially designed for healthcare environments.

Technical specifications:

- * Integrated cable gland
- * Optional Vertical Wall Slide Rail Mounting available in several lengths (480 mm - 720 mm - 960 mm - 1200 mm).
- * These wall rails can be easily cut to the required size. All cables also pass through the wall rail. (See Options below)
- * This 2 x 300 mm Folding Combo Arm simply slides into the wall rail to adjust to the desired height and fixed.
- * It does not have height adjustment, but has three horizontal axes of rotation.
- * The head of this arm complies with the standard for mounting screens: VESA MIS-D 75 mm and 100 mm. Tilt head.
- * Compatible with screens whose weight does not exceed 12,5 Kg.
- * Touch screen stability. * Screen tilt: 10°.
- * Screen rotation: 110° right, 110° left.
- * Arm rotation: 105° to the right, 105° to the left. * Total length 1115 mm
- * Foldable and removable keyboard and mouse holder: 580 x 200 mm
- * Compatible with multimedia terminals (TMM)
- * Color RAL 7024 (Graphite Grey) and White
- * All our medical arms are in conformity: CE, ROHS, Medical Grade, Regulations MDD 93/42 ECC.
- * Warranty: 5 years

Note: This arm can also be installed on one of our medical columns or trolleys

Do not hesitate to contact us if you have any questions about this product.

Warranty: 5 years

000.991.672-4

Graphite Grey and White

On Measure

= Depending on the elements

991.672-4

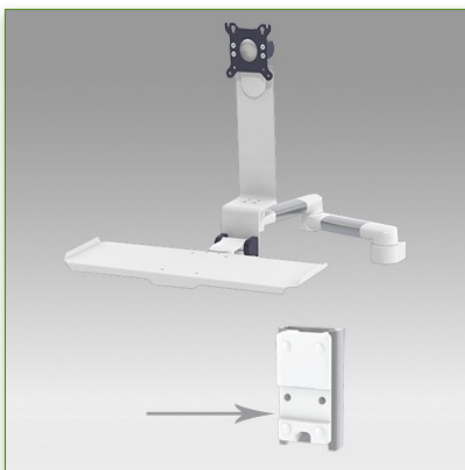
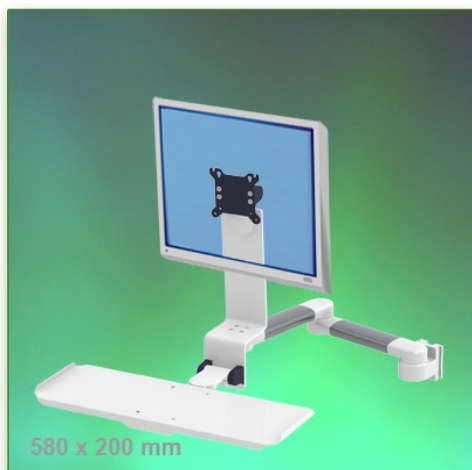

Display Compatibility: 26" Wide (Weight)
Supported Weight: 12,5 Kg
VESA standard: 75 / 100 mm
Keyboard-Mouse holder: 580 x 200 mm

Up to 26" Wide (Weight)
75/100 mm
12,5 Kg
580 x 200 mm

Combo Folding
MEDICAL GRADE

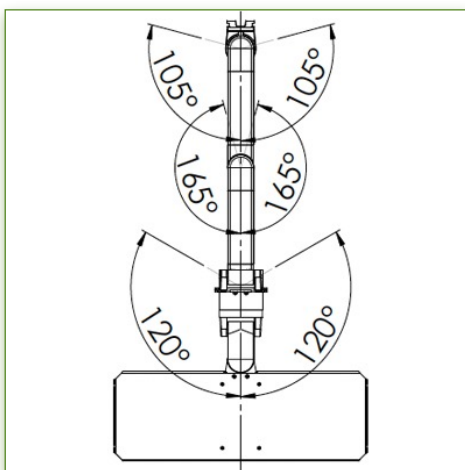
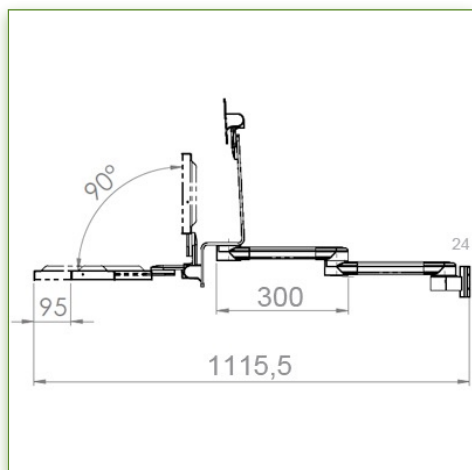

Do not hesitate to contact us if you have any questions about this product.

- Warranty: 5 years
- 000.991.672-4
- Graphite Grey and White
- On Measure
- = Depending on the elements
- 991.672-4

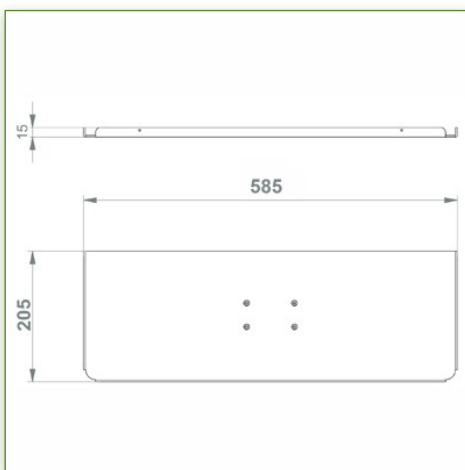

Anti-bacterial properties:

IT medical arms are now designed with Microban antibacterial protection, a revolutionary treatment that guarantees optimal hygiene. IT medical arms integrate Microban and other antibacterial agents into all medical products. It inhibits the growth of bacteria of all types. This is not a surface treatment. It is 100% in the totality of the product. It does not alter the physico-mechanical properties of the medical arm lift system. Simulations over 30 years show that 100% of the antibacterial properties are maintained. All medical articulated arms incorporate Microban. Microban is the world's leading provider of anti-bacterial solutions. It has been successfully applied for more than 35 years in a wide range of products used in the hospital, construction and food industries.

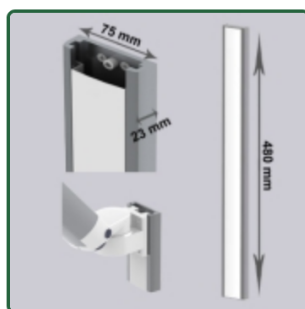
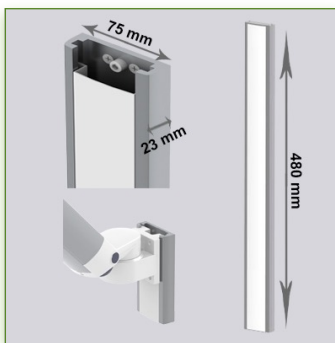
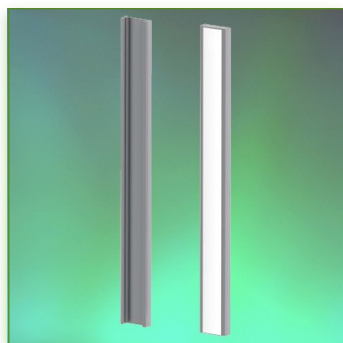

Vertical Wall Rail
with slide rail
480 mm

Part Number: 999.145



N'hésitez pas de nous contacter si vous avez des questions au sujet de ce produit.



Warranty: 5 years



000.999.145



Aluminium



On Measure



= Depending on the elements



999.145

Vertical wall rail with cable duct Height 480 mm. Allows the fixation of the medical arms

Vertical wall sliding rail compatible with all wall medical arms that have the wall rail mounting interface. It integrates all cables. Can be cut to any size. Delivered with cable cover.

It is coated with an anti-microbial agent offering hygiene and cleaning down to the last detail. Its modern design has been specially designed for healthcare environments.

Technical specifications:

- * Length 480 mm
- * Vertical Wall Mount
- * Colour Aluminium
- * All our medical arms are in conformity: CE, ROHS, Medical Grade, Regulations MDD 93/42 ECC.
- * Warranty: 5 years

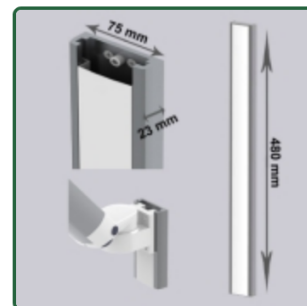
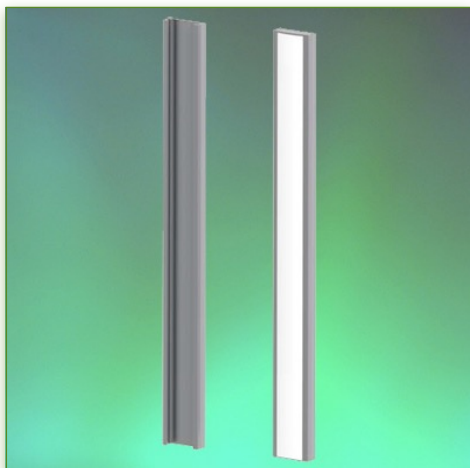

Vertical Wall Rail
with slide rail
480 mm

Part Number: 999.145



Medical Grade

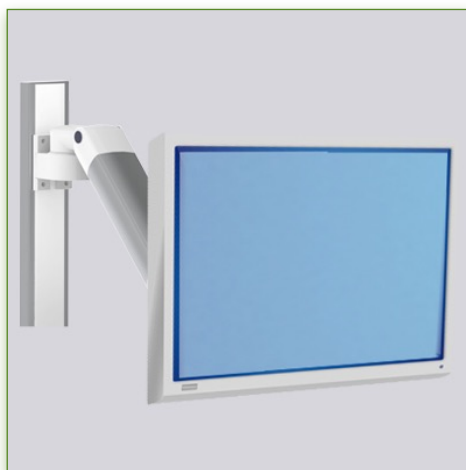
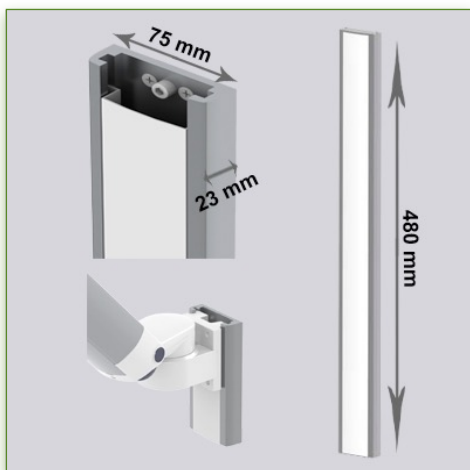

Do not hesitate to contact us if you have any questions about this product.



Warranty: 5 years



000.999.145



Aluminium



On Measure



= Depending on the elements



999.145

Anti-bacterial properties:

IT medical arms are now designed with Microban antibacterial protection, a revolutionary treatment that guarantees optimal hygiene. IT medical arms integrate Microban and other antibacterial agents into all medical products. It inhibits the growth of bacteria of all types. This is not a surface treatment.

It is 100% in the totality of the product.

It does not alter the physico-mechanical properties of the medical arm lift system. Simulations over 30 years show that 100% of the antibacterial properties are maintained.

All medical articulated arms incorporate Microban. Microban is the world's leading provider of anti-bacterial solutions. It has been successfully applied for more than 35 years in a wide range of products used in the hospital, construction and food industries.

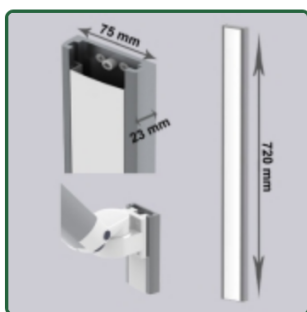
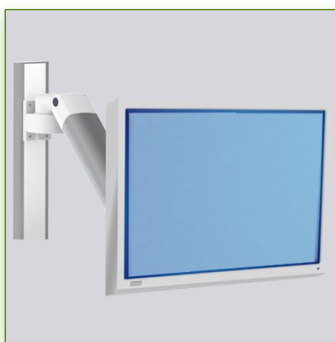
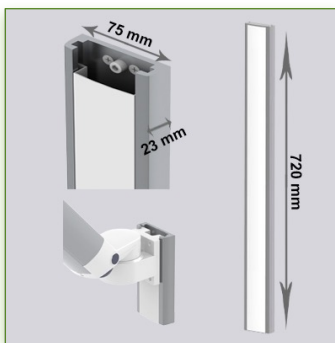
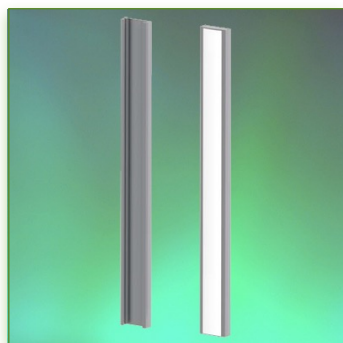

Vertical Wall Rail
with slide rail
720 mm

Part Number: 999.146



Do not hesitate to contact us if you have any questions about this product.



Warranty: 5 years



000.999.146



Aluminium



On Measure



= Depending on the elements



999.146

Vertical wall rail with cable duct Height 720 mm. Allows the fixation of the medical arms

Vertical wall sliding rail compatible with all wall medical arms that have the wall rail mounting interface. It integrates all cables. Can be cut to any size. Delivered with cable cover.

It is coated with an anti-microbial agent offering hygiene and cleaning down to the last detail. Its modern design has been specially designed for healthcare environments.

Technical specifications:

- * Length 720 mm
- * Vertical Wall Mount
- * Colour Aluminium
- * All our medical arms are in conformity:
CE, ROHS, Medical Grade, Regulations MDD 93/42 ECC.
- * Warranty: 5 years

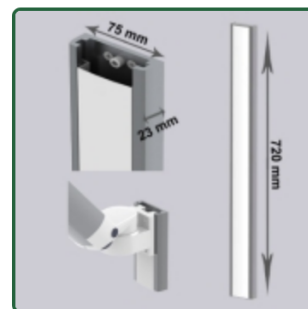
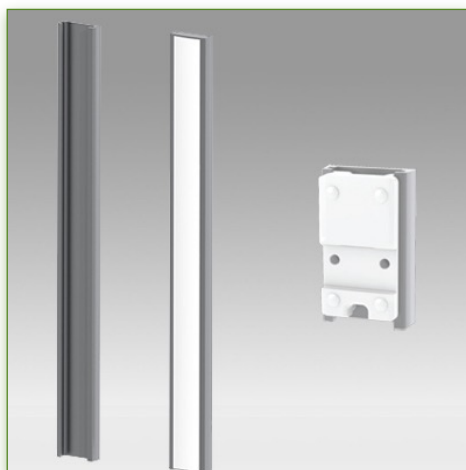
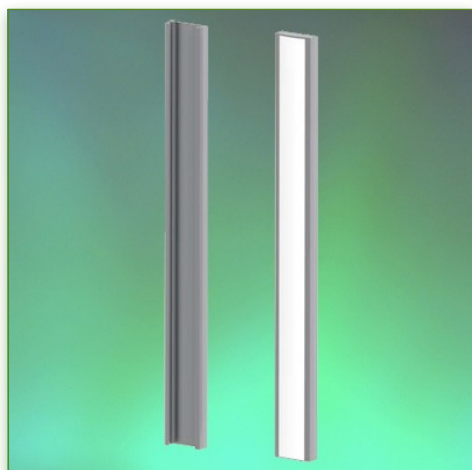

Vertical Wall Rail
with slide rail
720 mm

Part Number: 999.146



Medical Grade



Do not hesitate to contact us if you have any questions about this product.

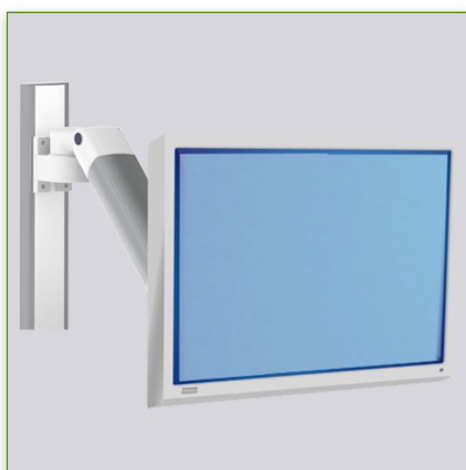
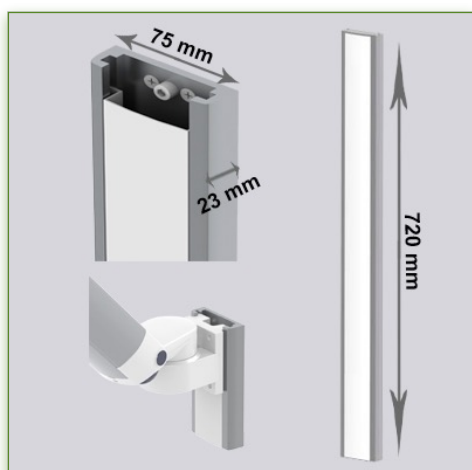

Warranty: 5 years



000.999.146



Aluminium



On Measure



= Depending on the elements



999.146

Anti-bacterial properties:

IT medical arms are now designed with Microban antibacterial protection, a revolutionary treatment that guarantees optimal hygiene. IT medical arms integrate Microban and other antibacterial agents into all medical products. It inhibits the growth of bacteria of all types. This is not a surface treatment.

It is 100% in the totality of the product.

It does not alter the physico-mechanical properties of the medical arm lift system. Simulations over 30 years show that 100% of the antibacterial properties are maintained.

All medical articulated arms incorporate Microban. Microban is the world's leading provider of anti-bacterial solutions. It has been successfully applied for more than 35 years in a wide range of products used in the hospital, construction and food industries.

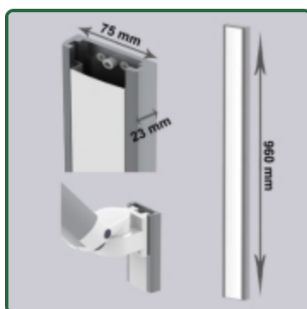
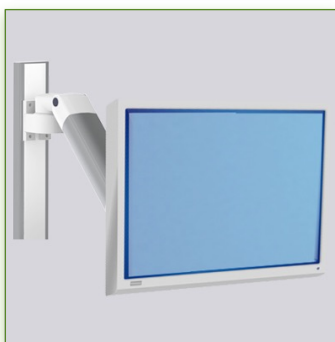
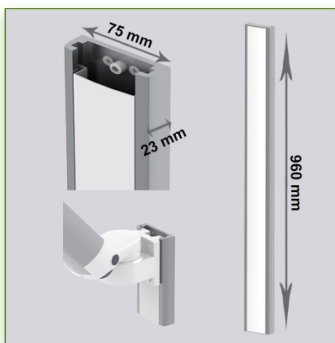
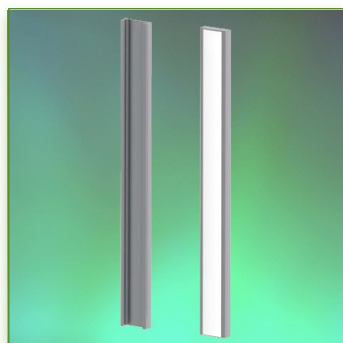

Vertical Wall Rail
with slide rail
960 mm

Part Number: 999.147



Do not hesitate to contact us if you have any questions about this product.



Warranty: 5 years



000.999.147



Aluminium



On Measure



= Depending on the elements



999.147

Vertical wall rail with cable duct Height 960 mm. Allows the fixation of the medical arms

Vertical wall sliding rail compatible with all wall medical arms that have the wall rail mounting interface. It integrates all cables. Can be cut to any size. Delivered with cable cover.

It is coated with an anti-microbial agent offering hygiene and cleaning down to the last detail. Its modern design has been specially designed for healthcare environments.

Technical specifications:

- * Length 960 mm
- * Vertical Wall Mount
- * Colour Aluminium
- * All our medical arms are in conformity: CE, ROHS, Medical Grade, Regulations MDD 93/42 ECC.
- * Warranty: 5 years

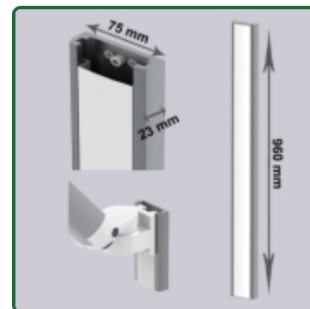
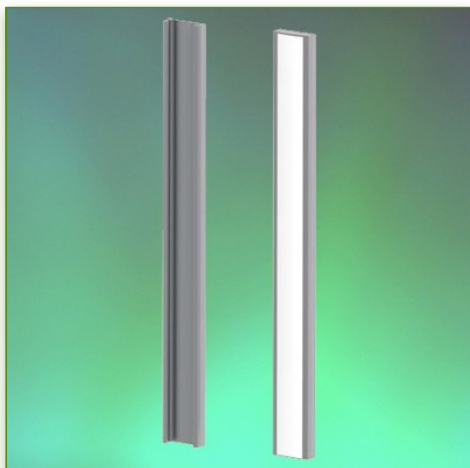

Vertical Wall Rail
with slide rail
960 mm

Part Number: 999.147



Medical Grade



Do not hesitate to contact us if you have any questions about this product.

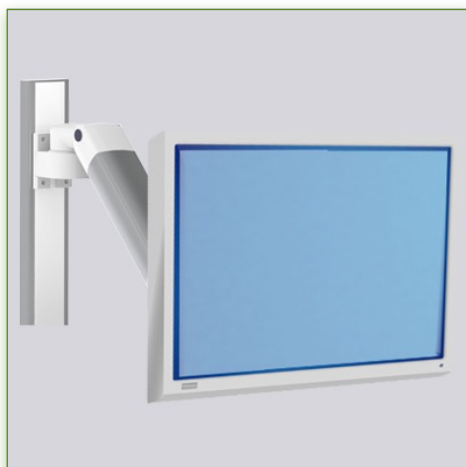
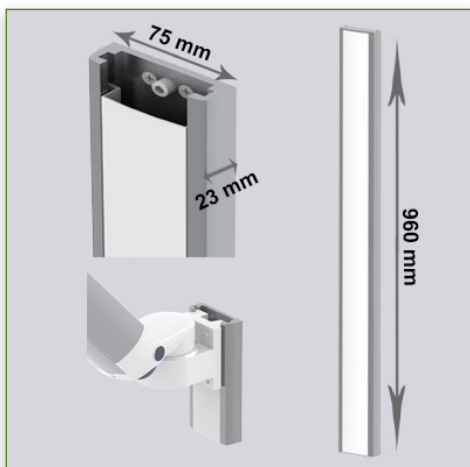

Warranty: 5 years



000.999.147



Aluminium



On Measure



= Depending on the elements



999.147

Anti-bacterial properties:

IT medical arms are now designed with Microban antibacterial protection, a revolutionary treatment that guarantees optimal hygiene. IT medical arms integrate Microban and other antibacterial agents into all medical products. It inhibits the growth of bacteria of all types. This is not a surface treatment.

It is 100% in the totality of the product. It does not alter the physico-mechanical properties of the medical arm lift system. Simulations over 30 years show that 100% of the antibacterial properties are maintained.

All medical articulated arms incorporate Microban. Microban is the world's leading provider of anti-bacterial solutions. It has been successfully applied for more than 35 years in a wide range of products used in the hospital, construction and food industries.

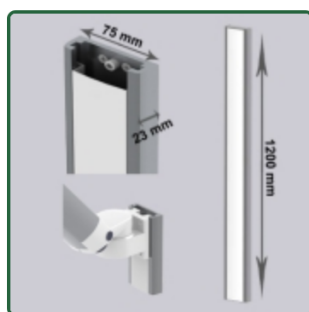
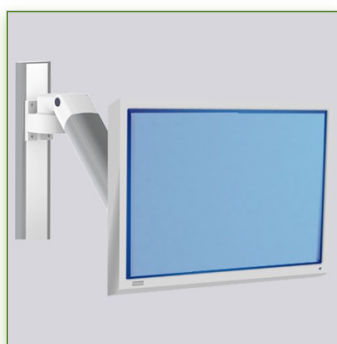
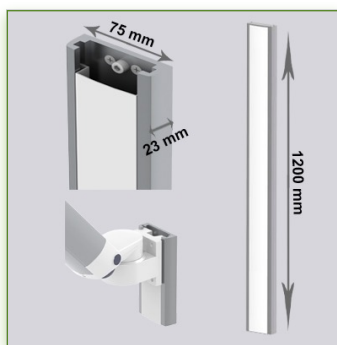
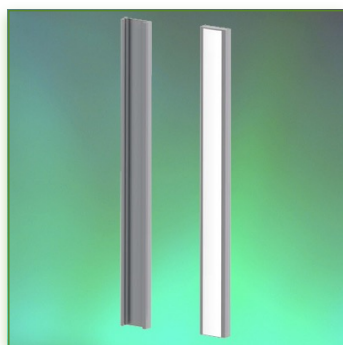

Vertical Wall Rail
with slide rail
1200 mm

Part Number: 999.148



Do not hesitate to contact us if you have any questions about this product.



Warranty: 5 years



000.999.148



Aluminium



On Measure



= Depending on the elements



999.148

Vertical wall rail with cable duct Height 1200 mm. Allows the fixation of the medical arms

Vertical wall sliding rail compatible with all wall medical arms that have the wall rail mounting interface. It integrates all cables. Can be cut to any size. Delivered with cable cover.

It is coated with an anti-microbial agent offering hygiene and cleaning down to the last detail. Its modern design has been specially designed for healthcare environments.

Technical specifications:

- * Length 1200 mm
- * Vertical Wall Mount
- * Colour Aluminium
- * All our medical arms are in conformity:
CE, ROHS, Medical Grade, Regulations MDD 93/42 ECC.
- * Warranty: 5 years

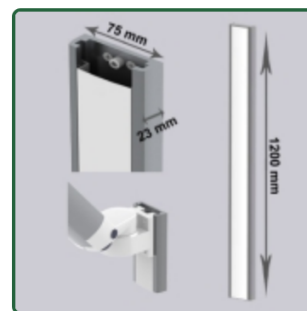
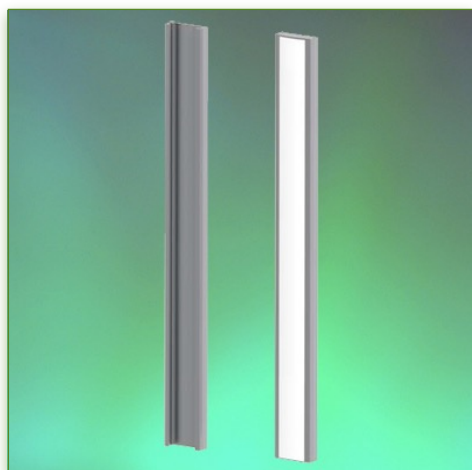

Vertical Wall Rail
with slide rail
1200 mm

Part Number: 999.148



Medical Grade



Do not hesitate to contact us if you have any questions about this product.

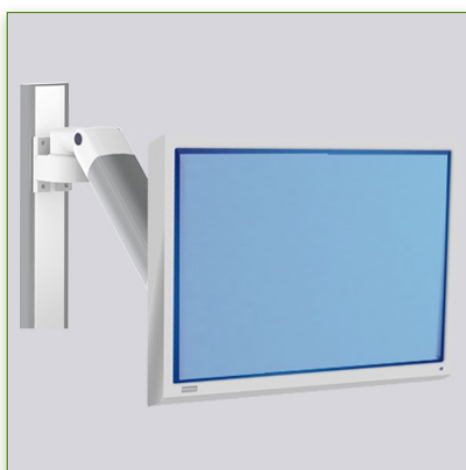
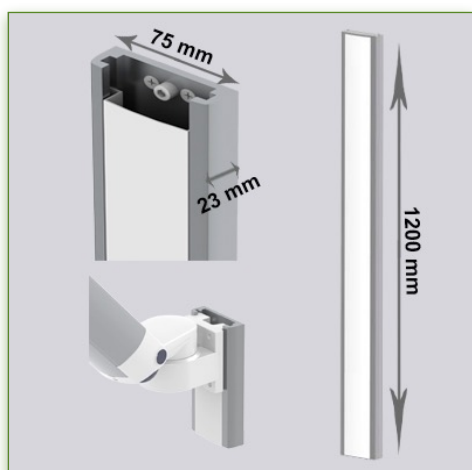

Warranty: 5 years



000.999.148



Aluminium



On Measure



= Depending on the elements



999.148

Anti-bacterial properties:

IT medical arms are now designed with Microban antibacterial protection, a revolutionary treatment that guarantees optimal hygiene. IT medical arms integrate Microban and other antibacterial agents into all medical products. It inhibits the growth of bacteria of all types. This is not a surface treatment.

It is 100% in the totality of the product. It does not alter the physico-mechanical properties of the medical arm lift system. Simulations over 30 years show that 100% of the antibacterial properties are maintained.

All medical articulated arms incorporate Microban. Microban is the world's leading provider of anti-bacterial solutions. It has been successfully applied for more than 35 years in a wide range of products used in the hospital, construction and food industries.

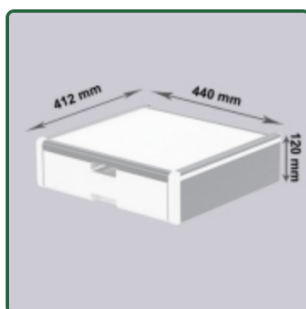
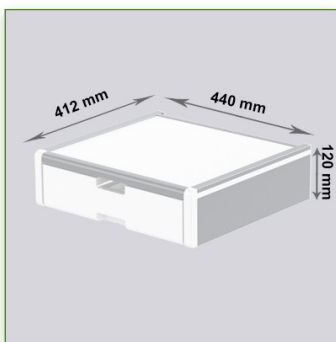
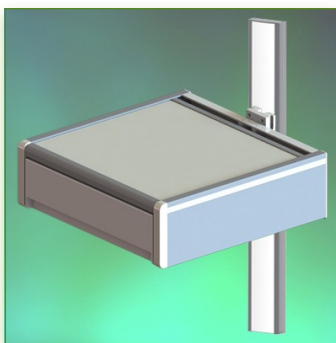

Single drawer
Mounting on Wall Rail

Part Number: 999.149



N'hésitez pas de nous contacter si vous avez des questions au sujet de ce produit.



Warranty: 5 years



000.999.149



Graphite Grey and White



On Measure



= Depending on the elements



999.149

Single drawer Vertical wall rail mounting with cable channel.

A work surface with additional storage space and a sliding drawer.

It is coated with an anti-microbial agent offering hygiene and cleaning down to the last detail. Its modern design has been specially designed for healthcare environments.

Technical specifications:

- * Integrated cable channel
- * Optional Vertical Wall Rail Mounting, several lengths available (480 mm - 720 mm - 960 mm - 1200 mm).
- * Optional mounting on worktop or floor or ceiling column, several heights of which are available:
(300 mm - 500 mm - 1500 mm - 2000 mm)
- These wall rails can be easily cut to the required size. All cables also pass through the wall rail.
- * Weight Supported by the drawer: 25 Kg
- * Working area 440 x 412 mm
- * Internal sliding drawer dimensions: 364 x 400 mm
- * Anodized, HPL and ABS (= anti-scratch, shock and scratch resistant) disinfectants)
- * Colour RAL 7024 (Graphite grey)
- * All our medical arms are in conformity:
CE, ROHS, Medical Grade, Regulations MDD 93/42 ECC.
- * Warranty: 5 years

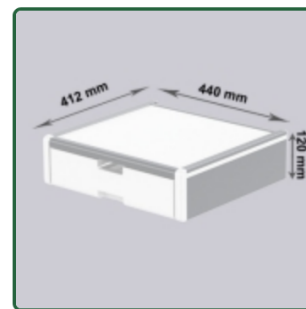
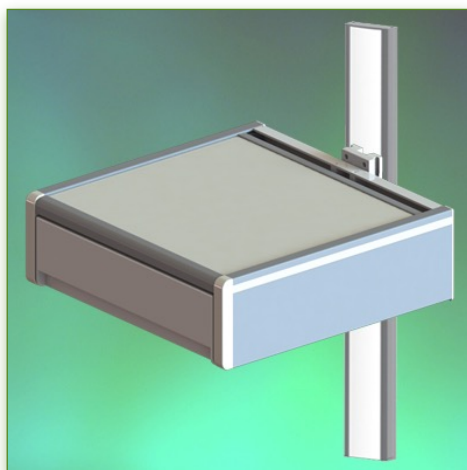
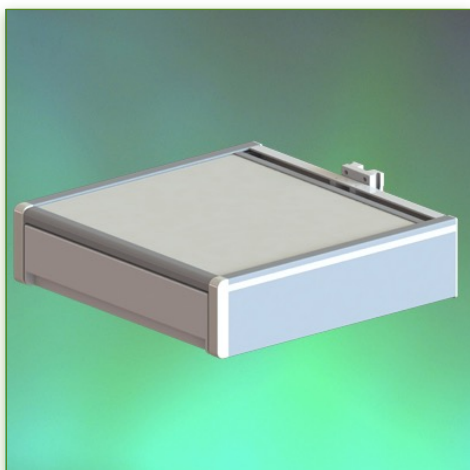

Single drawer
 Mounting on Wall Rail
 Part Number: 999.149



Do not hesitate to contact us if you have any questions about this product.

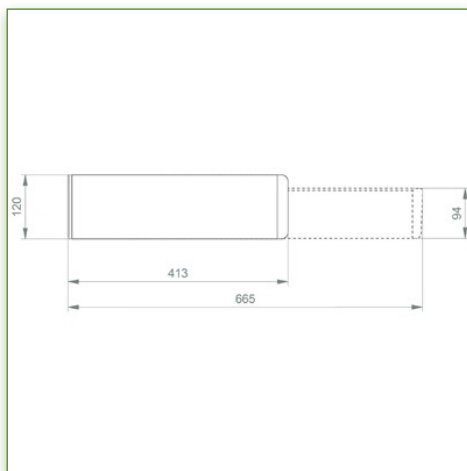
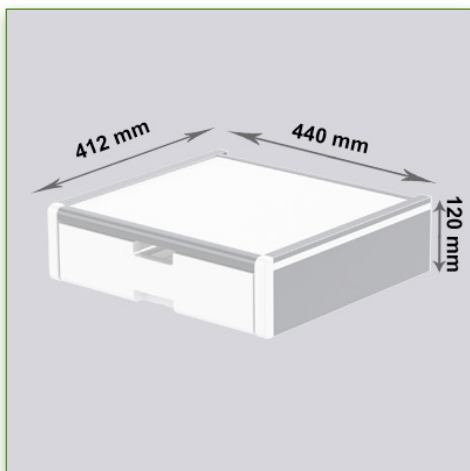

- Warranty: 5 years
- 000.999.149
- Graphite Grey and White
- On Measure
- = Depending on the elements
- 999.149

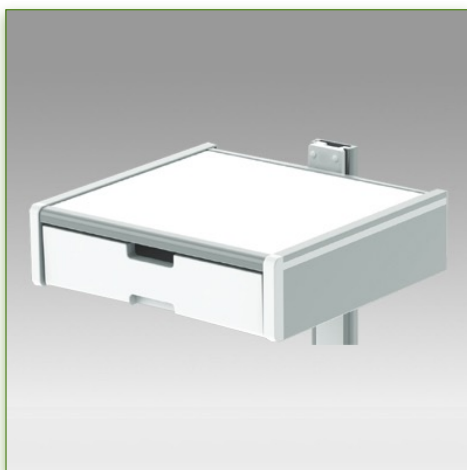
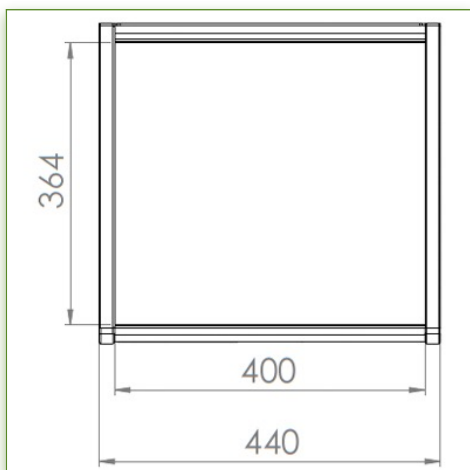

Anti-bacterial properties:

IT medical arms are now designed with Microban antibacterial protection, a revolutionary treatment that guarantees optimal hygiene. IT medical arms integrate Microban and other antibacterial agents into all medical products. It inhibits the growth of bacteria of all types. This is not a surface treatment. It is 100% in the totality of the product. It does not alter the physico-mechanical properties of the medical arm lift system. Simulations over 30 years show that 100% of the antibacterial properties are maintained. All medical articulated arms incorporate Microban. Microban is the world's leading provider of anti-bacterial solutions. It has been successfully applied for more than 35 years in a wide range of products used in the hospital, construction and food industries.

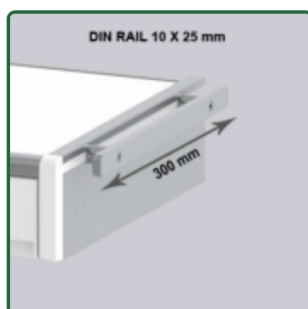
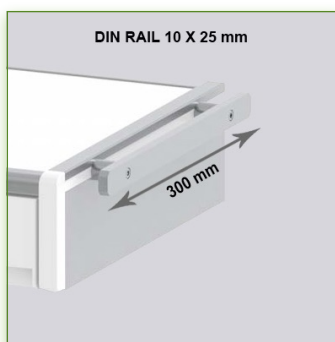
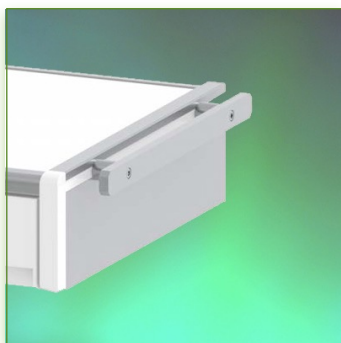

Din Rail 10 x 25 mm.
Length 300 mm.

Part Number: 999.150



Do not hesitate to contact us if you have any questions about this product.



Warranty: 5 years



000.999.150



Graphite Grey and White



On Measure



= Depending on the elements



999.150

Din Rail 10 x 25 mm. Length 300 mm. To mount on the sides of a console monitor or drawer.

This Din Rail Horizontal adapter allows the fixing of all the elements having the Din Rail Horizontal interface and in particular the accessories.

Ideal complement when no Din Rails are available or absent. To mount on the sides of a console screen or drawer.

It is coated with an anti-microbial agent offering hygiene and cleaning down to the last detail. Its modern design has been specially designed for healthcare environments.

Technical specifications:

- * Length 300 mm
- * Mounting on the sides of a drawer or console screen left or right
- * Colour RAL 7024 (Graphite grey)
- * All our medical arms are in conformity:
CE, ROHS, Medical Grade, Regulations MDD 93/42 ECC.
- * Warranty: 5 years

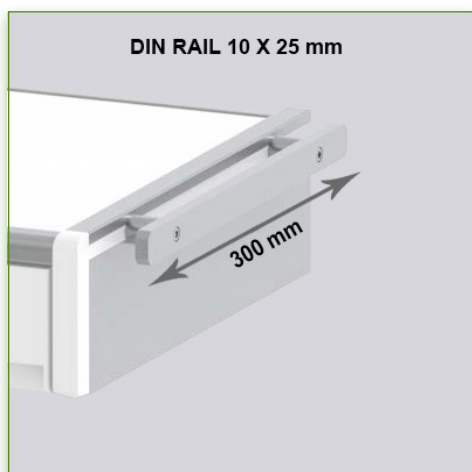
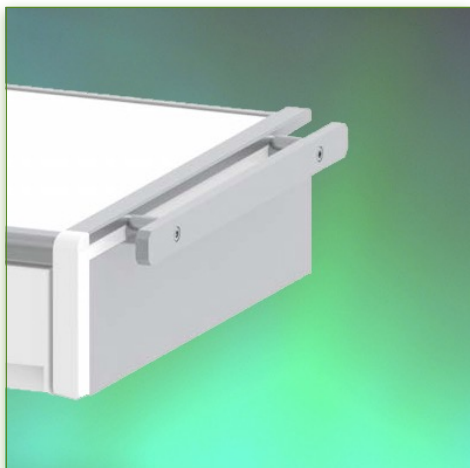

Din Rail 10 x 25 mm.
Length 300 mm.

Part Number: 999.150



Medical Grade



Do not hesitate to contact us if you have any questions about this product.



Warranty: 5 years



000.999.150



Graphite Grey and White



On Measure



= Depending on the elements



999.150

Anti-bacterial properties:

IT medical arms are now designed with Microban antibacterial protection, a revolutionary treatment that guarantees optimal hygiene. IT medical arms integrate Microban and other antibacterial agents into all medical products. It inhibits the growth of bacteria of all types. This is not a surface treatment.

It is 100% in the totality of the product. It does not alter the physico-mechanical properties of the medical arm lift system. Simulations over 30 years show that 100% of the antibacterial properties are maintained.

All medical articulated arms incorporate Microban. Microban is the world's leading provider of anti-bacterial solutions. It has been successfully applied for more than 35 years in a wide range of products used in the hospital, construction and food industries.

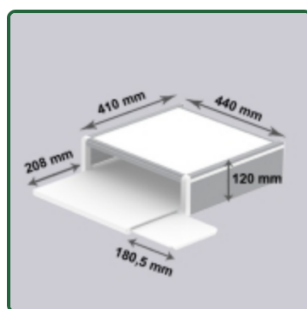
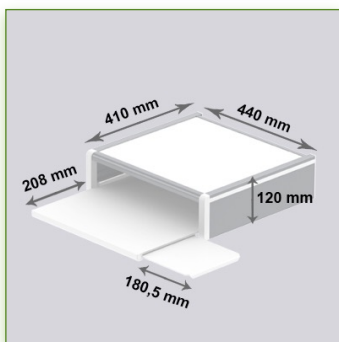
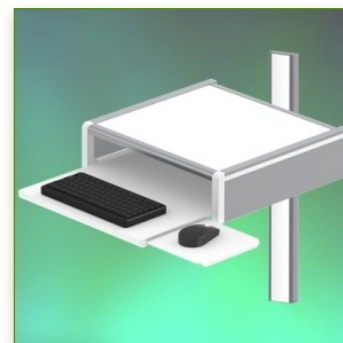
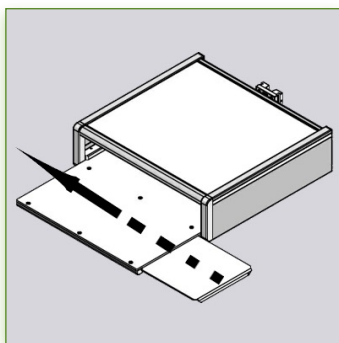
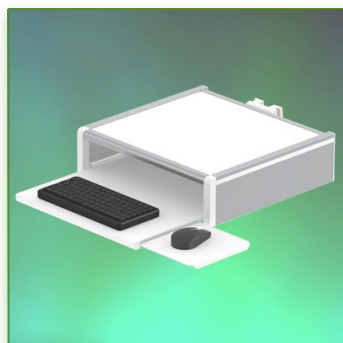

Drawer with Keyboard Holder
 Mounting on Wall Rail
 Part Number: 999.151

Do not hesitate to contact us if you have any questions about this product.

Warranty: 5 years

000.999.151

Graphite Grey and White

On Measure

= Depending on the elements

999.151

Drawer Keyboard Stand, Vertical Wall Rail Slide Mount

A work surface with additional storage space with integrated keyboard and mouse support.

It is coated with an anti-microbial agent offering hygiene and cleaning down to the last detail. Its modern design has been specially designed for healthcare environments.

Technical specifications:

- * Integrated cable channel
- * Optional Vertical Wall Rail Mounting, several lengths available (480 mm - 720 mm - 960 mm - 1200 mm). These wall rails can be easily cut to the required size. All cables also pass through the wall rail.
- * Optional mounting on worktop or floor or ceiling column, several heights of which are available: (300 mm - 500 mm - 1500 mm - 2000 mm)
- * Weight Supported by the drawer: 25 Kg
- * Working area 440 x 412 mm
- * Sliding mouse holder (right/left) with a usable mouse surface of 180.5 x 208 mm
- * Keyboard holder with 259.5 x 208 mm usable area
- * Anodized, HPL and ABS (= anti-scratch, shock and scratch resistant) disinfectants)
- * Colour RAL 7024 (Graphite grey)
- * All our medical arms are in conformity: CE, ROHS, Medical Grade, Regulations MDD 93/42 ECC.
- * Warranty: 5 years

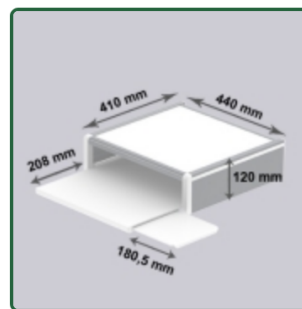
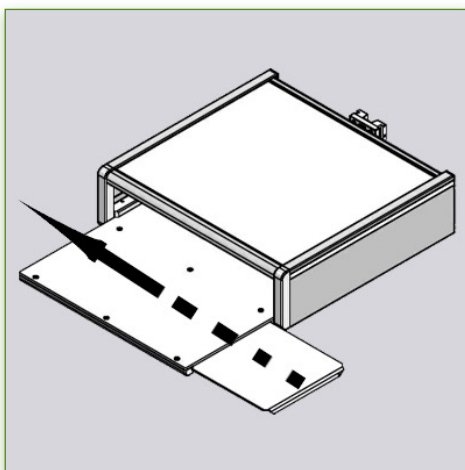
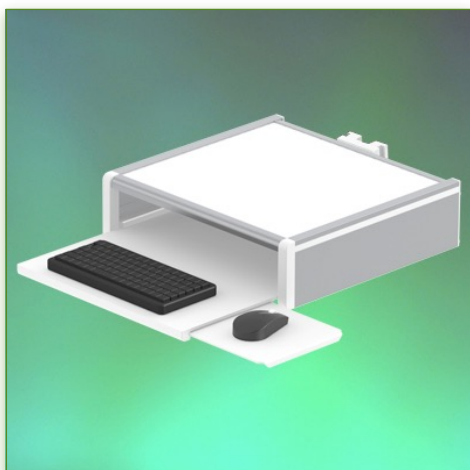

Drawer with Keyboard Holder
 Mounting on Wall Rail

Part Number: 999.151



Medical Grade



Do not hesitate to contact us if you have any questions about this product.

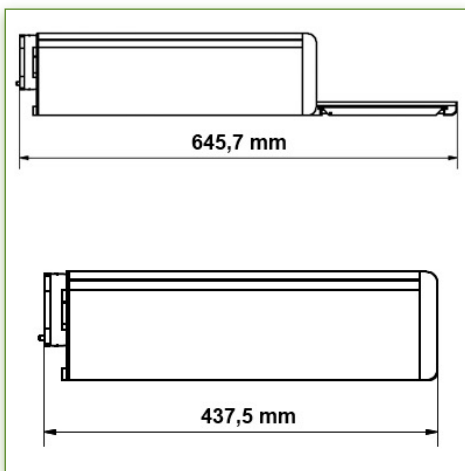
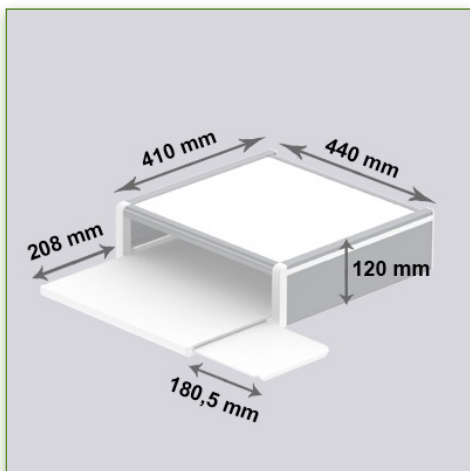

Warranty: 5 years



000.999.151



Graphite Grey and White



On Measure



= Depending on the elements



999.151

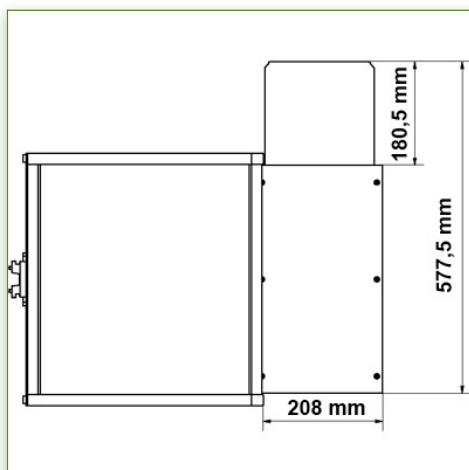
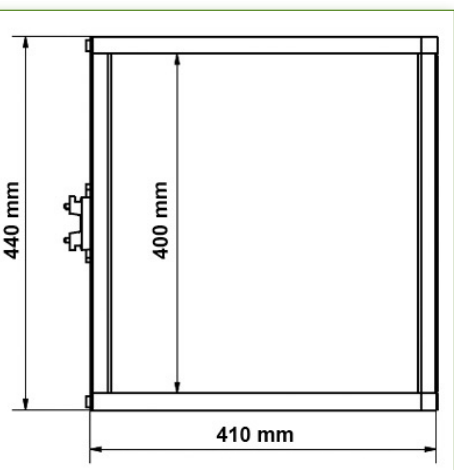

Anti-bacterial properties:

IT medical arms are now designed with Microban antibacterial protection, a revolutionary treatment that guarantees optimal hygiene. IT medical arms integrate Microban and other antibacterial agents into all medical products. It inhibits the growth of bacteria of all types. This is not a surface treatment.

It is 100% in the totality of the product. It does not alter the physico-mechanical properties of the medical arm lift system. Simulations over 30 years show that 100% of the antibacterial properties are maintained.

All medical articulated arms incorporate Microban. Microban is the world's leading provider of anti-bacterial solutions. It has been successfully applied for more than 35 years in a wide range of products used in the hospital, construction and food industries.

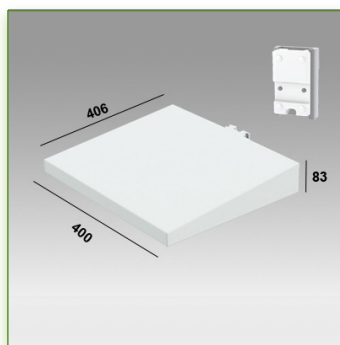

HD worktop
 Mounting on Wall Rail

Part Number: 999.153



Do not hesitate to contact us if you have any questions about this product.



Warranty: 5 years



000.999.153



Graphite Grey and White



On Measure



= Depending on the elements



999.153

HD work surface Vertical Wall Rail Slide Mount

A complementary work surface covered with an anti-microbial agent offering hygiene and cleaning down to the last detail.

Its modern design has been specially designed for healthcare environments.

Technical specifications:

* Optional Vertical Wall Rail Mounting, several lengths available (480 mm - 720 mm - 960 mm - 1200 mm).

These wall rails can be easily cut to the required size. All cables also pass through the wall rail.

* Optional mounting on worktop or floor or ceiling column, several heights of which are available:
 (300 mm - 500 mm - 1500 mm - 2000 mm)

* Weight Supported by the work surface: 35 Kg

* Working area 435 x 410 x 47 mm

* Anodized, HPL and ABS (= anti-scratch, shock and scratch resistant) disinfectants)

* Colour RAL 7024 (Graphite grey)

* All our medical arms are in conformity:
 CE, ROHS, Medical Grade, Regulations MDD 93/42 ECC.

* Warranty: 5 years

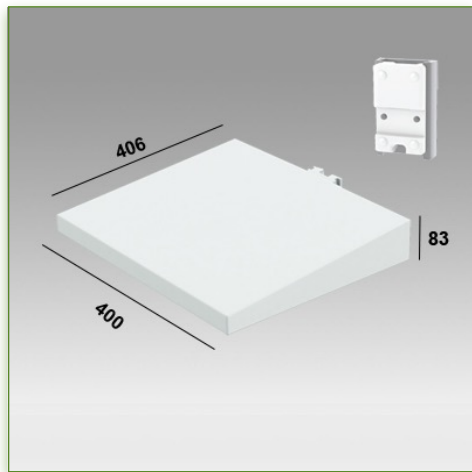
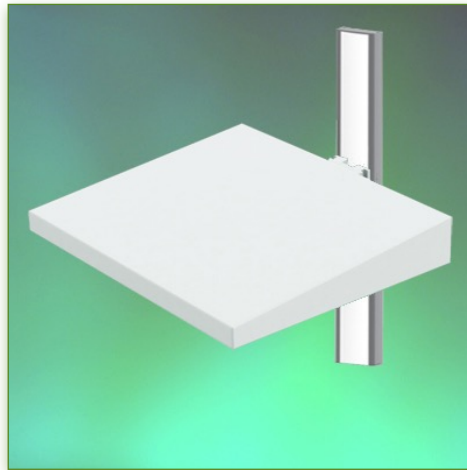
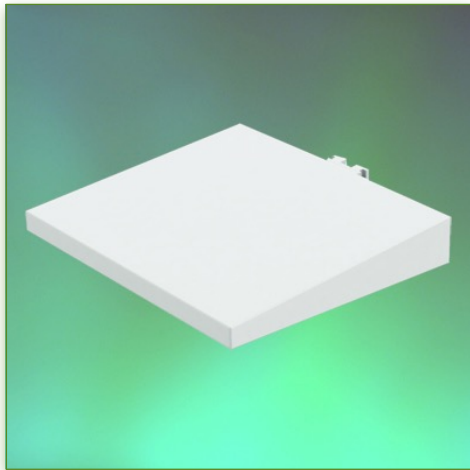

HD worktop
 Mounting on Wall Rail

Part Number: 999.153



Medical Grade



Do not hesitate to contact us if you have any questions about this product.



Warranty: 5 years



000.999.153



Graphite Grey and White



On Measure



= Depending on the elements



999.153

Anti-bacterial properties:

IT medical arms are now designed with Microban antibacterial protection, a revolutionary treatment that guarantees optimal hygiene. IT medical arms integrate Microban and other antibacterial agents into all medical products. It inhibits the growth of bacteria of all types. This is not a surface treatment.

It is 100% in the totality of the product.

It does not alter the physico-mechanical properties of the medical arm lift system. Simulations over 30 years show that 100% of the antibacterial properties are maintained.

All medical articulated arms incorporate Microban. Microban is the world's leading provider of anti-bacterial solutions. It has been successfully applied for more than 35 years in a wide range of products used in the hospital, construction and food industries.

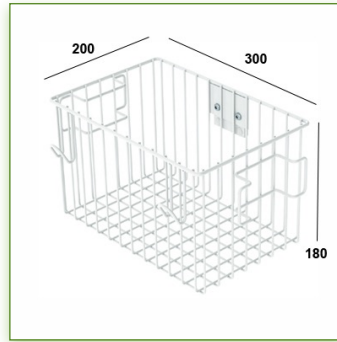
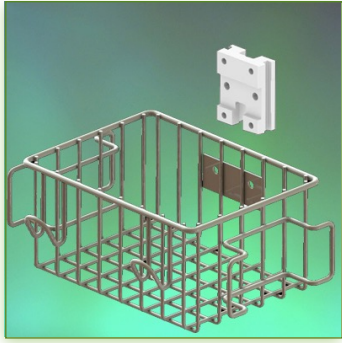

Large Service Basket
Mounting on Wall Rail

Part Number: 999.154



Do not hesitate to contact us if you have any questions about this product.



Warranty: 5 years



000.999.154



Anodised aluminium



On Measure



= Depending on the elements



999.154

Large service basket 200 x 300 x 180 mm on vertical sliding wall rail

Large service basket in anodised aluminium.

Its open structure allows direct access to its contents.

It is coated with an anti-microbial agent offering hygiene and cleaning down to the last detail. Its modern design has been specially designed for healthcare environments.

Technical specifications:

* Optional Vertical Wall Rail Mounting, several lengths available (480 mm - 720 mm - 960 mm - 1200 mm).

These wall rails can be easily cut to the required size. All cables also pass through the wall rail.

* Optional mounting on worktop or floor or ceiling column, several heights of which are available:
(300 mm - 500 mm - 1500 mm - 2000 mm)

* Dimensions: 180 x 300 x 200 mm

* Colour Anodised aluminium

* All our medical arms are in conformity:
CE, ROHS, Medical Grade, Regulations MDD 93/42 ECC.

* Warranty: 5 years

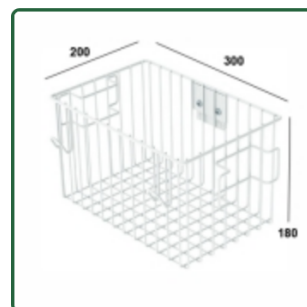

Large Service Basket
Mounting on Wall Rail

Part Number: 999.154



Medical Grade



Do not hesitate to contact us if you have any questions about this product.



Warranty: 5 years



000.999.154



Anodised aluminium



On Measure



= Depending on the elements



999.154

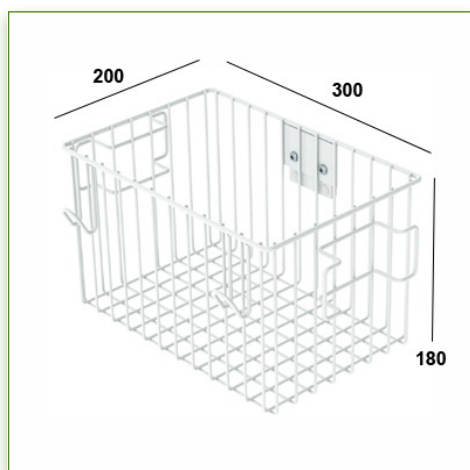

Anti-bacterial properties:

IT medical arms are now designed with Microban antibacterial protection, a revolutionary treatment that guarantees optimal hygiene. IT medical arms integrate Microban and other antibacterial agents into all medical products. It inhibits the growth of bacteria of all types. This is not a surface treatment.

It is 100% in the totality of the product. It does not alter the physico-mechanical properties of the medical arm lift system. Simulations over 30 years show that 100% of the antibacterial properties are maintained.

All medical articulated arms incorporate Microban. Microban is the world's leading provider of anti-bacterial solutions. It has been successfully applied for more than 35 years in a wide range of products used in the hospital, construction and food industries.

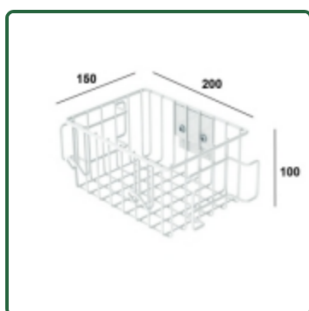
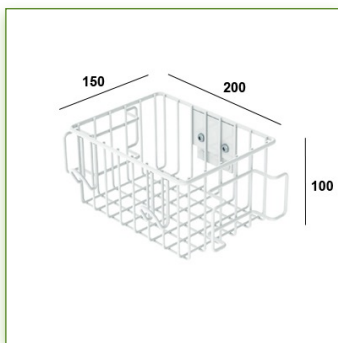

Small Service Basket
Mounting on Wall Rail

Part Number: 999.155



Do not hesitate to contact us if you have any questions about this product.



Warranty: 5 years



000.999.155



Anodised aluminium



On Measure



= Depending on the elements



999.155

Small service basket 100 x 150 x 200 mm on vertical sliding wall rail

Small service basket in anodized aluminium.

Its open structure allows direct access to its contents.

It is coated with an anti-microbial agent offering hygiene and cleaning down to the last detail. Its modern design has been specially designed for healthcare environments.

Technical specifications:

* Optional Vertical Wall Rail Mounting, several lengths available (480 mm - 720 mm - 960 mm - 1200 mm).

These wall rails can be easily cut to the required size. All cables also pass through the wall rail.

* Optional mounting on worktop or floor or ceiling column, several heights of which are available:
(300 mm - 500 mm - 1500 mm - 2000 mm)

* Dimensions: 100 x 150 x 200 mm

* Colour Anodised aluminium

* All our medical arms are in conformity:
CE, ROHS, Medical Grade, Regulations MDD 93/42 ECC.

* Warranty: 5 years

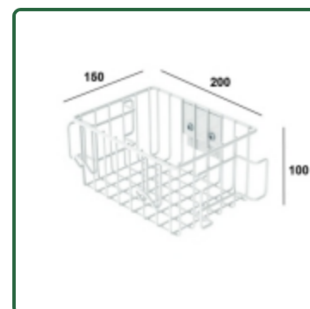
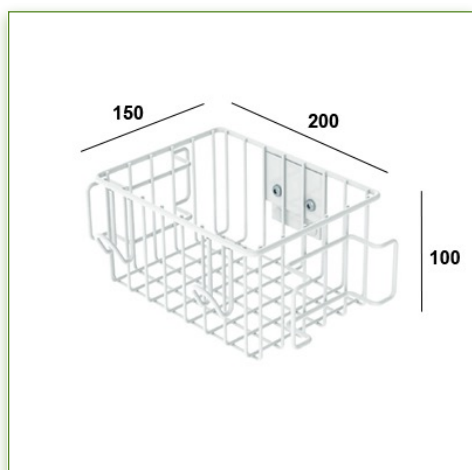
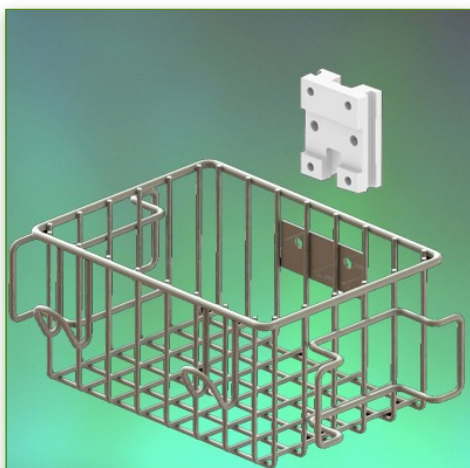

Small Service Basket
Mounting on Wall Rail

Part Number: 999.155



Medical Grade



Do not hesitate to contact us if you have any questions about this product.



Warranty: 5 years



000.999.155



Anodised aluminium



On Measure



= Depending on the elements



999.155

Anti-bacterial properties:

IT medical arms are now designed with Microban antibacterial protection, a revolutionary treatment that guarantees optimal hygiene. IT medical arms integrate Microban and other antibacterial agents into all medical products. It inhibits the growth of bacteria of all types. This is not a surface treatment.

It is 100% in the totality of the product.

It does not alter the physico-mechanical properties of the medical arm lift system. Simulations over 30 years show that 100% of the antibacterial properties are maintained.

All medical articulated arms incorporate Microban. Microban is the world's leading provider of anti-bacterial solutions. It has been successfully applied for more than 35 years in a wide range of products used in the hospital, construction and food industries.

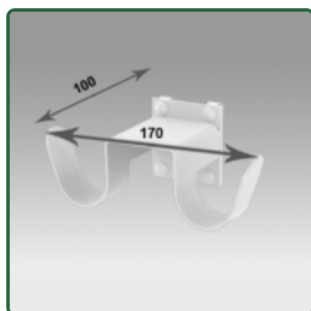
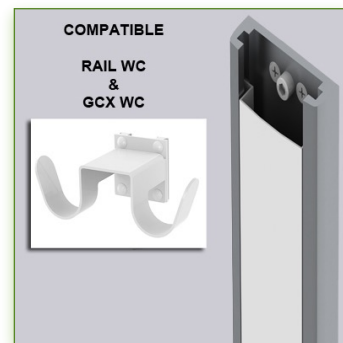
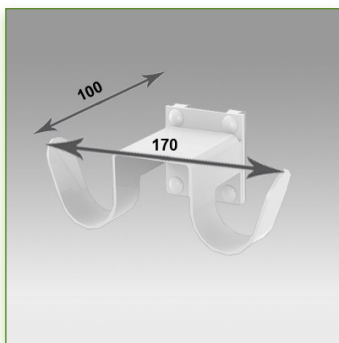
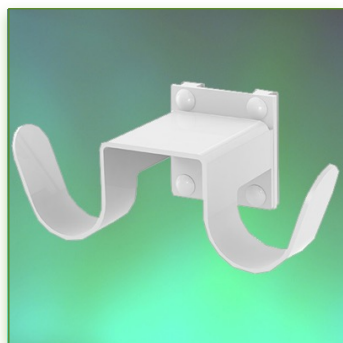

Double cable hooks Mounting on Wall Rail
 Part Number: 999.156

Do not hesitate to contact us if you have any questions about this product.

Warranty: 5 years

000.999.156

Graphite grey

On Measure

= Depending on the elements

999.156

Double cable hooks for vertical sliding wall rail mounting

This cable hook with its vertical wall rail mounting interface is the ideal complement when certain cables that are too long have to be suspended.

It is coated with an anti-microbial agent offering hygiene and cleaning down to the last detail. Its modern design has been specially designed for healthcare environments.

Technical specifications:

* Optional Vertical Wall Rail Mounting, several lengths available (480 mm - 720 mm - 960 mm - 1200 mm).

These wall rails can be easily cut to the required size. All cables also pass through the wall rail.

* Optional mounting on worktop or floor or ceiling column, several heights of which are available:
 (300 mm - 500 mm - 1500 mm - 2000 mm)

* Cable hook with two pins

* Length 170 mm

* Wall Mount

* Colour RAL 7024 (Graphite grey)

* All our medical arms are in conformity:
 CE, ROHS, Medical Grade, Regulations MDD 93/42 ECC.

* Warranty: 5 years

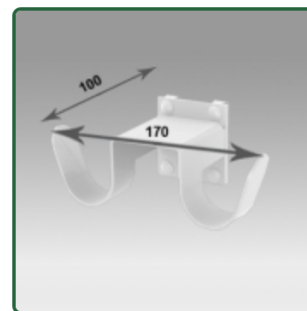
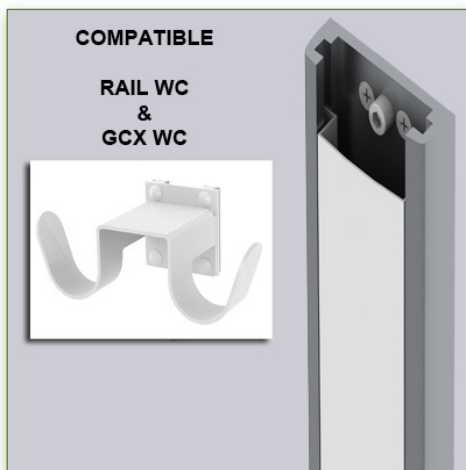
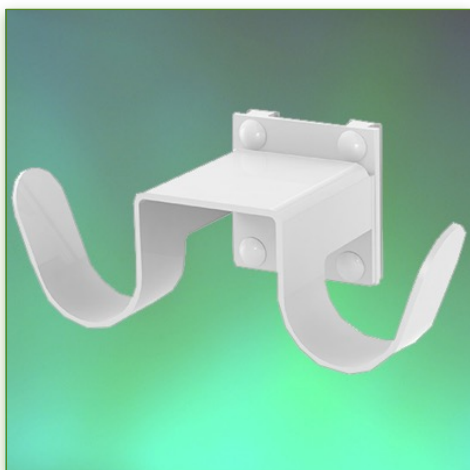

Double cable hooks Mounting on Wall Rail

Part Number: 999.156



Medical Grade



Do not hesitate to contact us if you have any questions about this product.

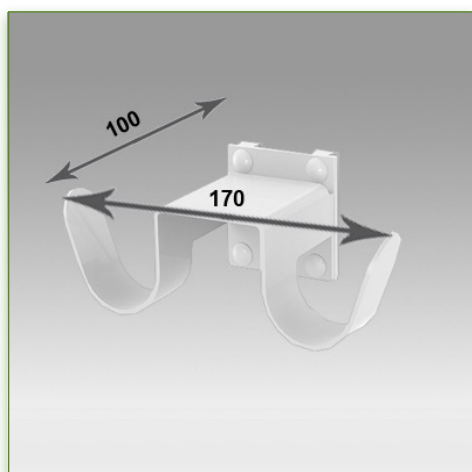

Warranty: 5 years



000.999.156



Graphite grey



On Measure



= Depending on the elements



999.156

Anti-bacterial properties:

IT medical arms are now designed with Microban antibacterial protection, a revolutionary treatment that guarantees optimal hygiene. IT medical arms integrate Microban and other antibacterial agents into all medical products. It inhibits the growth of bacteria of all types. This is not a surface treatment.

It is 100% in the totality of the product.

It does not alter the physico-mechanical properties of the medical arm lift system. Simulations over 30 years show that 100% of the antibacterial properties are maintained.

All medical articulated arms incorporate Microban. Microban is the world's leading provider of anti-bacterial solutions. It has been successfully applied for more than 35 years in a wide range of products used in the hospital, construction and food industries.

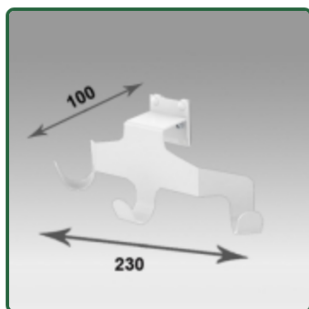
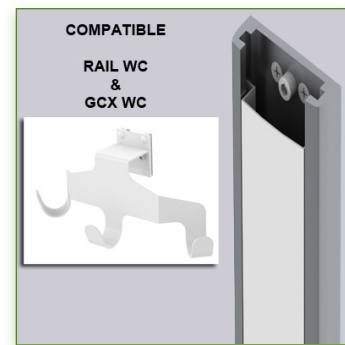
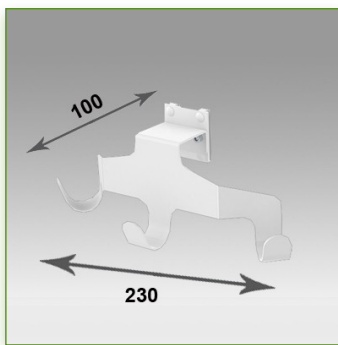

Triple cable hooks, mounting on Wall Rail
 Part Number: 999.157



Do not hesitate to contact us if you have any questions about this product.



Warranty: 5 years



000.999.157



Graphite grey



On Measure



= Depending on the elements



999.157

Triple cable hooks for vertical sliding wall rail mounting

This cable hook with its vertical wall rail mounting interface is the ideal complement when certain cables that are too long have to be suspended.

It is coated with an anti-microbial agent offering hygiene and cleaning down to the last detail. Its modern design has been specially designed for healthcare environments.

Technical specifications:

* Optional Vertical Wall Rail Mounting, several lengths available (480 mm - 720 mm - 960 mm - 1200 mm).

These wall rails can be easily cut to the required size. All cables also pass through the wall rail.

* Optional mounting on worktop or floor or ceiling column, several heights of which are available:
 (300 mm - 500 mm - 1500 mm - 2000 mm)

* Hook for cable with three pins

* Length 230 mm

* Wall Mount

* Colour RAL 7024 (Graphite grey)

* All our medical arms are in conformity:
 CE, ROHS, Medical Grade, Regulations MDD 93/42 ECC.
 Warranty: 5 years

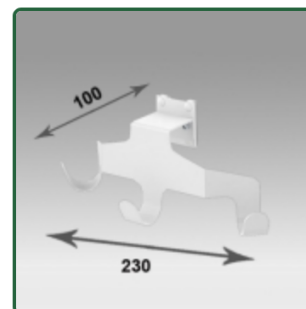
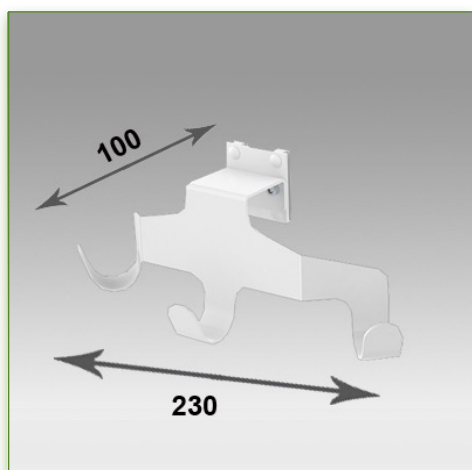

Triple cable hooks, mounting on Wall Rail

Part Number: 999.157



Medical Grade



Do not hesitate to contact us if you have any questions about this product.



Warranty: 5 years



000.999.157



Graphite grey



On Measure



= Depending on the elements



999.157

Anti-bacterial properties:

IT medical arms are now designed with Microban antibacterial protection, a revolutionary treatment that guarantees optimal hygiene. IT medical arms integrate Microban and other antibacterial agents into all medical products. It inhibits the growth of bacteria of all types. This is not a surface treatment.

It is 100% in the totality of the product.

It does not alter the physico-mechanical properties of the medical arm lift system. Simulations over 30 years show that 100% of the antibacterial properties are maintained.

All medical articulated arms incorporate Microban. Microban is the world's leading provider of anti-bacterial solutions. It has been successfully applied for more than 35 years in a wide range of products used in the hospital, construction and food industries.

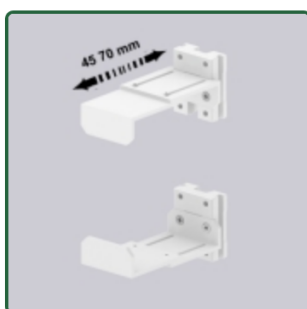
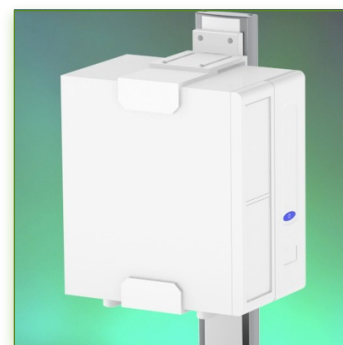
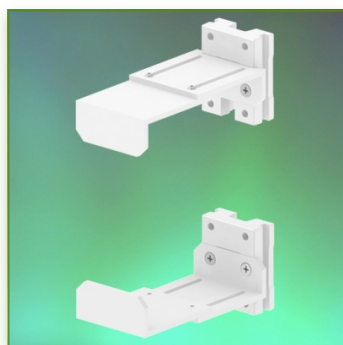

CPU holder Adjustable
45-70 mm
mounting on Wall Rail

Part Number: 999.158



Do not hesitate to contact us if you have any questions about this product.



Warranty: 5 years



000.999.158



Graphite Grey



On Measure



= Depending on the elements



999.158

Adjustable CPU Holder 45-70 mm on vertical sliding wall rail

This CPU support is adjustable in width and height and is suitable for the majority of CPU's on the market.

It is coated with an anti-microbial agent offering hygiene and cleaning down to the last detail. Its modern design has been specially designed for healthcare environments.

Technical specifications:

* Optional Vertical Wall Rail Mounting, several lengths available (480 mm - 720 mm - 960 mm - 1200 mm).

These wall rails can be easily cut to the required size. All cables also pass through the wall rail.

* Optional mounting on worktop or floor or ceiling column, several heights of which are available:
(300 mm - 500 mm - 1500 mm - 2000 mm)

* Adjustable in height according to the length of the wall rail

* Adjustable width from 45 to 70 mm

* Colour RAL 7024 (Graphite grey)

* All our medical arms are in conformity:
CE, ROHS, Medical Grade, Regulations MDD 93/42 ECC.

* Warranty: 5 years

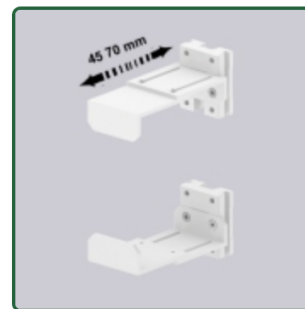
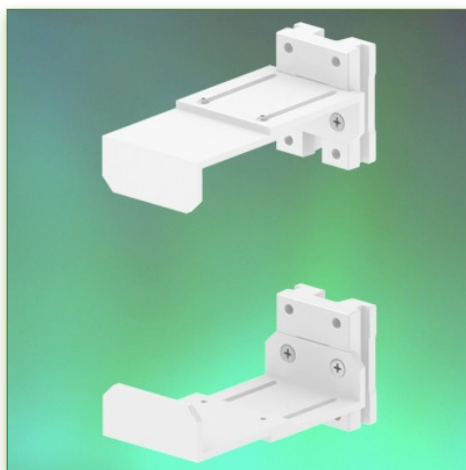

CPU holder Adjustable
45-70 mm
mounting on Wall Rail

Part Number: 999.158



Medical Grade



Do not hesitate to contact us if you have any questions about this product.

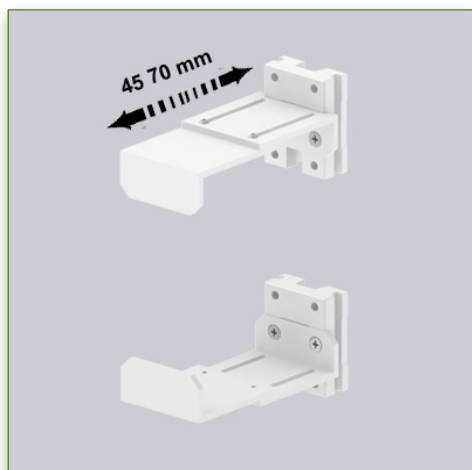

COMPATIBLE

RAIL WC
&
GCX WC



Warranty: 5 years



000.999.158



Graphite Grey



On Measure



= Depending on the elements



999.158

Anti-bacterial properties:

IT medical arms are now designed with Microban antibacterial protection, a revolutionary treatment that guarantees optimal hygiene. IT medical arms integrate Microban and other antibacterial agents into all medical products. It inhibits the growth of bacteria of all types. This is not a surface treatment.

It is 100% in the totality of the product.

It does not alter the physico-mechanical properties of the medical arm lift system. Simulations over 30 years show that 100% of the antibacterial properties are maintained.

All medical articulated arms incorporate Microban. Microban is the world's leading provider of anti-bacterial solutions. It has been successfully applied for more than 35 years in a wide range of products used in the hospital, construction and food industries.

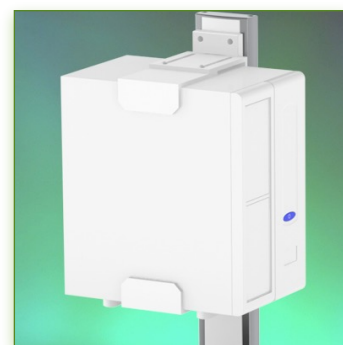
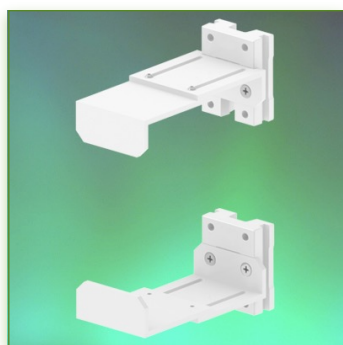

CPU holder Adjustable
60-100 mm
mounting on Wall Rail

Part Number: 999.159



Do not hesitate to contact us if you have any questions about this product.



Warranty: 5 years



000.999.159



Graphite Grey



On Measure



= Depending on the elements



999.159

Adjustable CPU Holder 60-100 mm on vertical sliding wall rail

This CPU support is adjustable in width and height and is suitable for the majority of CPU's on the market.

It is coated with an anti-microbial agent offering hygiene and cleaning down to the last detail. Its modern design has been specially designed for healthcare environments.

Technical specifications:

* Optional Vertical Wall Rail Mounting, several lengths available (480 mm - 720 mm - 960 mm - 1200 mm).

These wall rails can be easily cut to the required size. All cables also pass through the wall rail.

* Optional mounting on worktop or floor or ceiling column, several heights of which are available:
(300 mm - 500 mm - 1500 mm - 2000 mm)

* Adjustable in height according to the length of the wall rail

* Adjustable width from 60 to 100 mm

* Colour RAL 7024 (Graphite grey)

* All our medical arms are in conformity:
CE, ROHS, Medical Grade, Regulations MDD 93/42 ECC.

* Warranty: 5 years

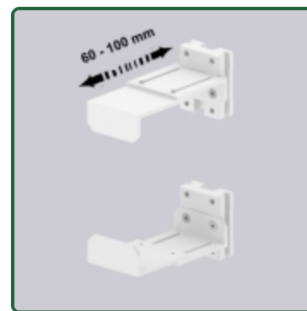
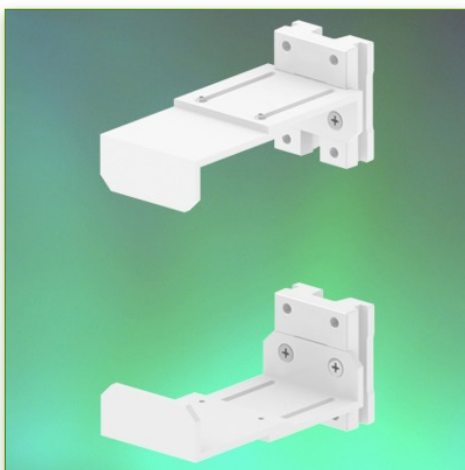

CPU holder Adjustable
60-100 mm
mounting on Wall Rail

Part Number: 999.159



Medical Grade



Do not hesitate to contact us if you have any questions about this product.

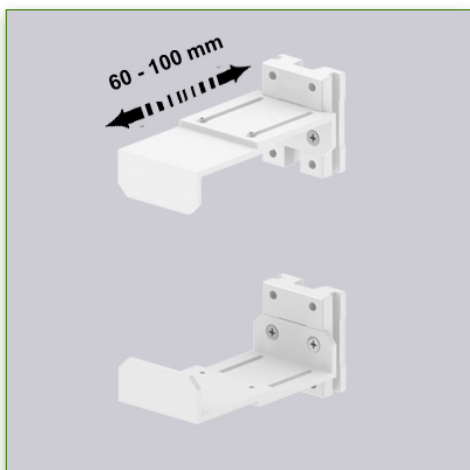

Warranty: 5 years



000.999.159



Graphite Grey



On Measure



= Depending on the elements



999.159

Anti-bacterial properties:

IT medical arms are now designed with Microban antibacterial protection, a revolutionary treatment that guarantees optimal hygiene. IT medical arms integrate Microban and other antibacterial agents into all medical products. It inhibits the growth of bacteria of all types. This is not a surface treatment.

It is 100% in the totality of the product.

It does not alter the physico-mechanical properties of the medical arm lift system. Simulations over 30 years show that 100% of the antibacterial properties are maintained.

All medical articulated arms incorporate Microban. Microban is the world's leading provider of anti-bacterial solutions. It has been successfully applied for more than 35 years in a wide range of products used in the hospital, construction and food industries.

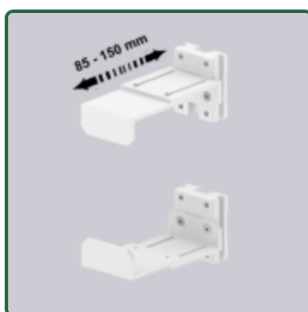
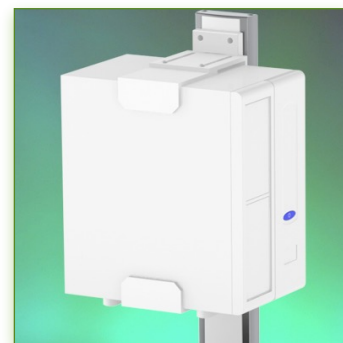
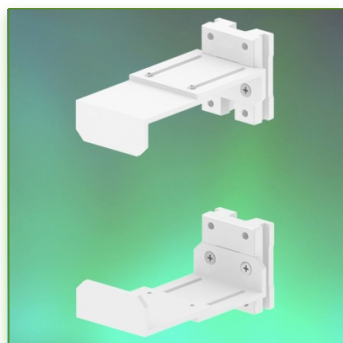

CPU holder Adjustable
85-150 mm
mounting on Wall Rail

Part Number: 999.160



Do not hesitate to contact us if you have any questions about this product.



Warranty: 5 years



000.999.160



Graphite Grey



On Measure



= Depending on the elements



999.160

Adjustable CPU Holder 85-150 mm on vertical sliding wall rail

This CPU support is adjustable in width and height and is suitable for the majority of CPU's on the market.

It is coated with an anti-microbial agent offering hygiene and cleaning down to the last detail. Its modern design has been specially designed for healthcare environments.

Technical specifications:

* Optional Vertical Wall Rail Mounting, several lengths available (480 mm - 720 mm - 960 mm - 1200 mm).

These wall rails can be easily cut to the required size. All cables also pass through the wall rail.

* Optional mounting on worktop or floor or ceiling column, several heights of which are available:
(300 mm - 500 mm - 1500 mm - 2000 mm)

* Adjustable in height according to the length of the wall rail

* Adjustable width from 85 to 150 mm

* Colour RAL 7024 (Graphite grey)

* All our medical arms are in conformity:
CE, ROHS, Medical Grade, Regulations MDD 93/42 ECC.

* Warranty: 5 years

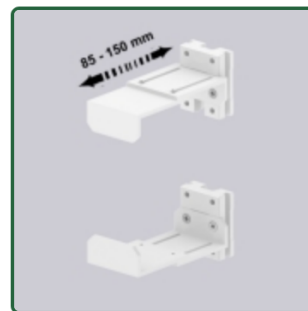
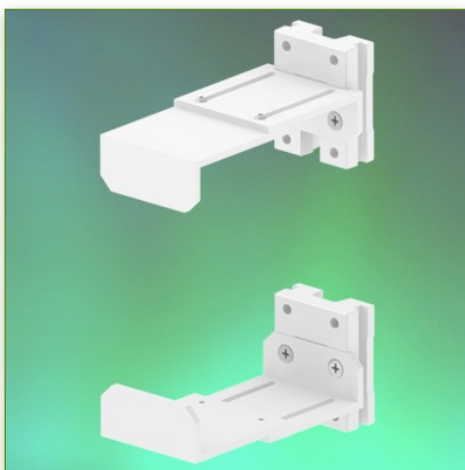

CPU holder Adjustable
85-150 mm
mounting on Wall Rail

Part Number: 999.160



Medical Grade

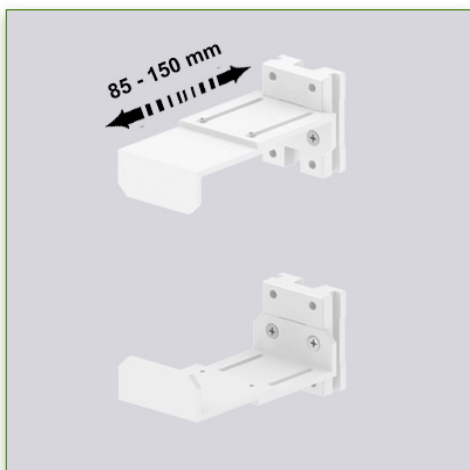

COMPATIBLE

**RAIL WC
&
GCX WC**



Do not hesitate to contact us if you have any questions about this product.



Warranty: 5 years



000.999.160



Graphite Grey



On Measure



= Depending on the elements



999.160

Anti-bacterial properties:

IT medical arms are now designed with Microban antibacterial protection, a revolutionary treatment that guarantees optimal hygiene. IT medical arms integrate Microban and other antibacterial agents into all medical products. It inhibits the growth of bacteria of all types. This is not a surface treatment.

It is 100% in the totality of the product. It does not alter the physico-mechanical properties of the medical arm lift system. Simulations over 30 years show that 100% of the antibacterial properties are maintained.

All medical articulated arms incorporate Microban. Microban is the world's leading provider of anti-bacterial solutions. It has been successfully applied for more than 35 years in a wide range of products used in the hospital, construction and food industries.

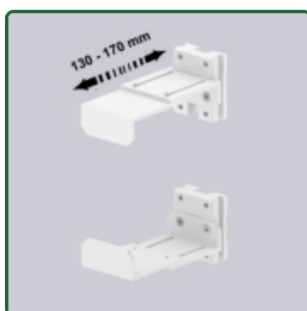
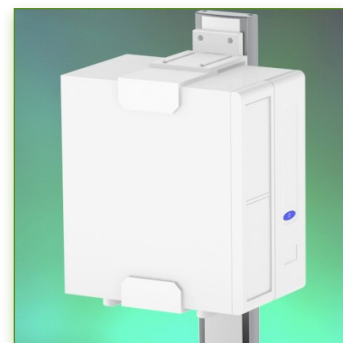
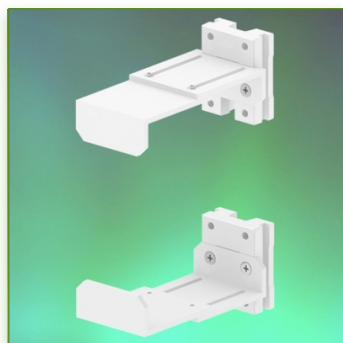

CPU holder Adjustable
 130-170 mm mounting on
 Wall Rail

Part Number: 999.161



Do not hesitate to contact us if you have any questions about this product.



Warranty: 5 years



000.999.161



Graphite Grey



On Measure



= Depending on the elements



999.161

Adjustable CPU Holder 130-170 mm on vertical sliding wall rail

This CPU support is adjustable in width and height and is suitable for the majority of CPU's on the market.

It is coated with an anti-microbial agent offering hygiene and cleaning down to the last detail. Its modern design has been specially designed for healthcare environments.

Technical specifications:

* Optional Vertical Wall Rail Mounting, several lengths available (480 mm - 720 mm - 960 mm - 1200 mm).

These wall rails can be easily cut to the required size. All cables also pass through the wall rail.

* Optional mounting on worktop or floor or ceiling column, several heights of which are available:
 (300 mm - 500 mm - 1500 mm - 2000 mm)

* Adjustable in height according to the length of the wall rail

* Adjustable width from 130 to 170 mm

* Colour RAL 7024 (Graphite grey)

* All our medical arms are in conformity:
 CE, ROHS, Medical Grade, Regulations MDD 93/42 ECC.

* Warranty: 5 years

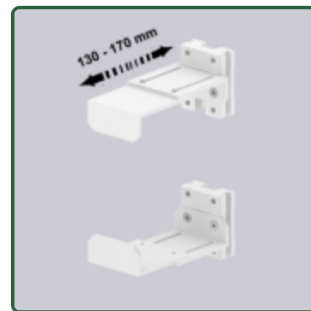
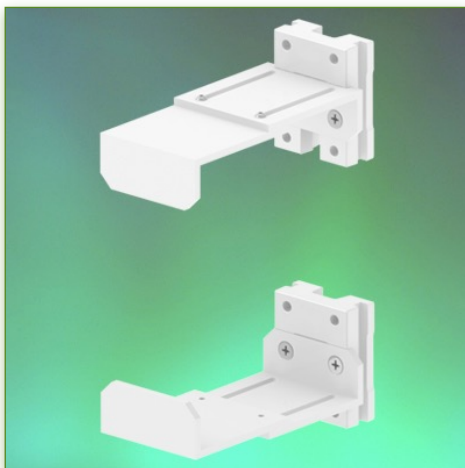

CPU holder Adjustable
130-170 mm mounting on
Wall Rail

Part Number: 999.161



Medical Grade



Do not hesitate to contact us if you have any questions about this product.



Warranty: 5 years



000.999.161



Graphite Grey



On Measure



= Depending on the elements



999.161

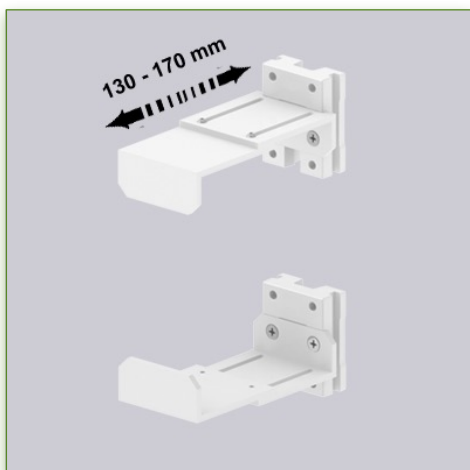

Anti-bacterial properties:

IT medical arms are now designed with Microban antibacterial protection, a revolutionary treatment that guarantees optimal hygiene. IT medical arms integrate Microban and other antibacterial agents into all medical products. It inhibits the growth of bacteria of all types. This is not a surface treatment. It is 100% in the totality of the product. It does not alter the physico-mechanical properties of the medical arm lift system. Simulations over 30 years show that 100% of the antibacterial properties are maintained. All medical articulated arms incorporate Microban. Microban is the world's leading provider of anti-bacterial solutions. It has been successfully applied for more than 35 years in a wide range of products used in the hospital, construction and food industries.

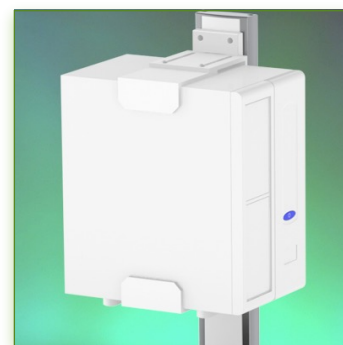
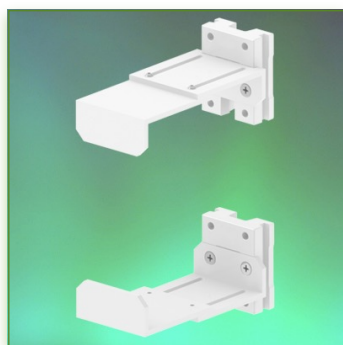

CPU holder Adjustable
 170-215 mm mounting on
 Wall Rail

Part Number: 999.162



Do not hesitate to contact us if you have any questions about this product.



Warranty: 5 years



000.999.162



Graphite Grey



On Measure



= Depending on the elements



999.162

Adjustable CPU Holder 170-215 mm on vertical sliding wall rail

This CPU support is adjustable in width and height and is suitable for the majority of CPU's on the market.

It is coated with an anti-microbial agent offering hygiene and cleaning down to the last detail. Its modern design has been specially designed for healthcare environments.

Technical specifications:

* Optional Vertical Wall Rail Mounting, several lengths available (480 mm - 720 mm - 960 mm - 1200 mm).

These wall rails can be easily cut to the required size. All cables also pass through the wall rail.

* Optional mounting on worktop or floor or ceiling column, several heights of which are available:
 (300 mm - 500 mm - 1500 mm - 2000 mm)

* Adjustable in height according to the length of the wall rail

* Adjustable width from 170 to 215 mm

* Colour RAL 7024 (Graphite grey)

* All our medical arms are in conformity:
 CE, ROHS, Medical Grade, Regulations MDD 93/42 ECC.

* Warranty: 5 years

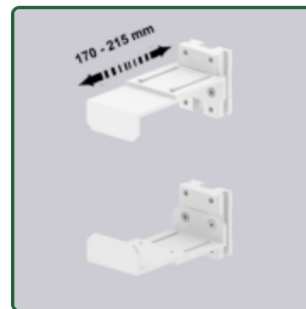
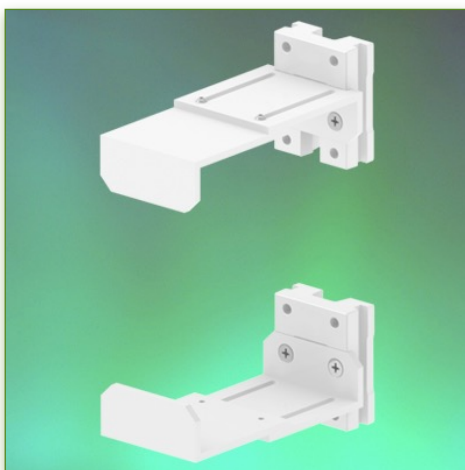

CPU holder Adjustable
170-215 mm mounting on
Wall Rail

Part Number: 999.162



Medical Grade



Do not hesitate to contact us if you have any questions about this product.

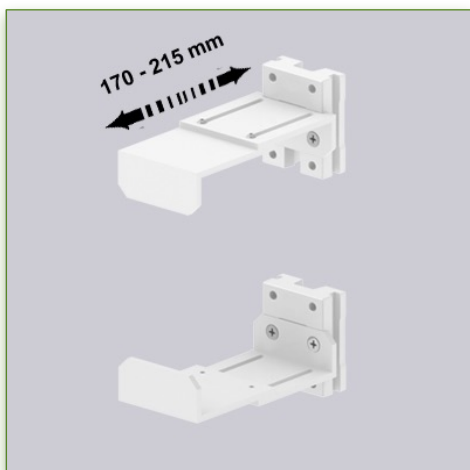

Warranty: 5 years



000.999.162



Graphite Grey



On Measure



= Depending on the elements



999.162

Anti-bacterial properties:

IT medical arms are now designed with Microban antibacterial protection, a revolutionary treatment that guarantees optimal hygiene. IT medical arms integrate Microban and other antibacterial agents into all medical products. It inhibits the growth of bacteria of all types. This is not a surface treatment.

It is 100% in the totality of the product.

It does not alter the physico-mechanical properties of the medical arm lift system. Simulations over 30 years show that 100% of the antibacterial properties are maintained.

All medical articulated arms incorporate Microban. Microban is the world's leading provider of anti-bacterial solutions. It has been successfully applied for more than 35 years in a wide range of products used in the hospital, construction and food industries.

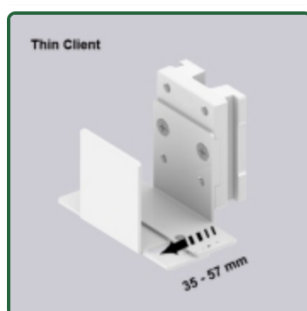
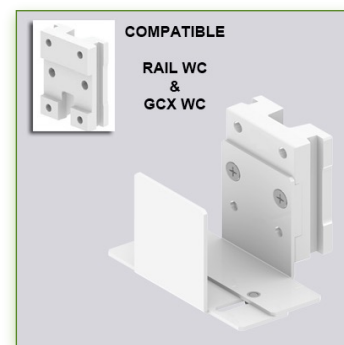
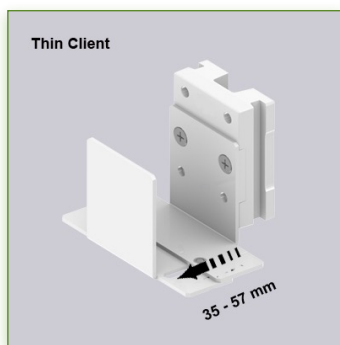
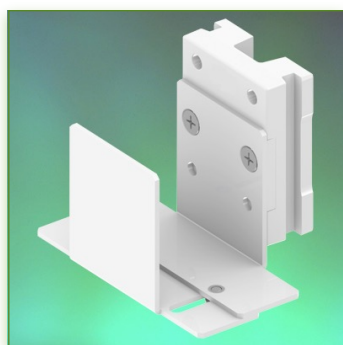

Universal Stand Adjustable
 35-57 mm mounting on Wall
 Rail
 Part Number: 999.163

 Do not hesitate to contact us if you have any questions about this product.

 Warranty: 5 years

 000.999.163

 Graphite Grey

 On Measure

 = Depending on the elements

 999.163

Adjustable 35-57 mm Universal Holder on vertical sliding wall rail

This universal adjustable width and height support is suitable for the majority of small machines on the market.

It is coated with an anti-microbial agent offering hygiene and cleaning down to the last detail. Its modern design has been specially designed for healthcare environments.

Technical specifications:

* Optional Vertical Wall Rail Mounting, several lengths available (480 mm - 720 mm - 960 mm - 1200 mm).

These wall rails can be easily cut to the required size. All cables also pass through the wall rail.

* Optional mounting on worktop or floor or ceiling column, several heights of which are available:
 (300 mm - 500 mm - 1500 mm - 2000 mm)

* Adjustable in height according to the length of the wall rail

* Adjustable width from 35 to 57 mm

* Colour RAL 7024 (Graphite grey)

* All our medical arms are in conformity:
 CE, ROHS, Medical Grade, Regulations MDD 93/42 ECC.

* Warranty: 5 years

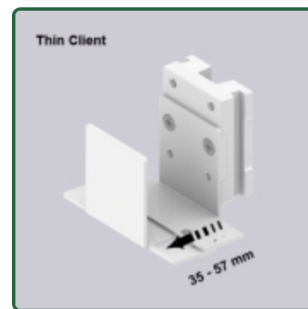
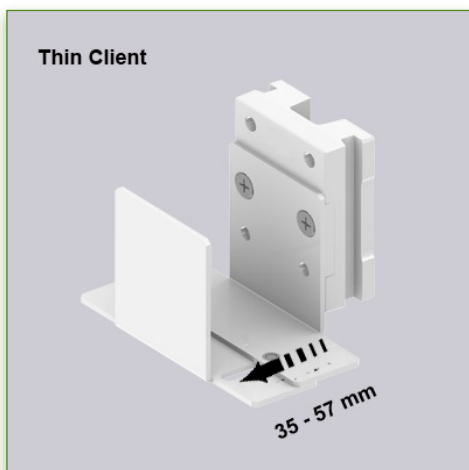
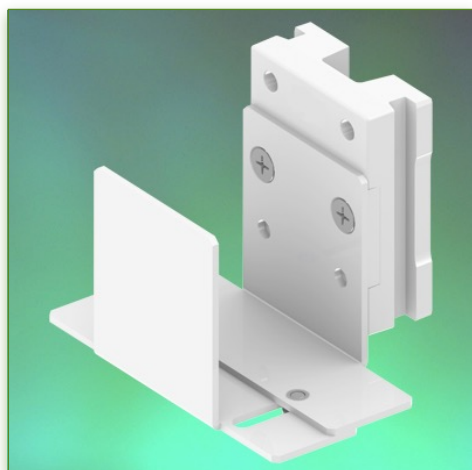

Universal Stand Adjustable
35-57 mm mounting on Wall
Rail
Part Number: 999.163



Do not hesitate to contact us if you have any questions about this product.

Warranty: 5 years

000.999.163

Graphite Grey

On Measure

= Depending on the elements

999.163

Anti-bacterial properties:

IT medical arms are now designed with Microban antibacterial protection, a revolutionary treatment that guarantees optimal hygiene. IT medical arms integrate Microban and other antibacterial agents into all medical products. It inhibits the growth of bacteria of all types. This is not a surface treatment. It is 100% in the totality of the product. It does not alter the physico-mechanical properties of the medical arm lift system. Simulations over 30 years show that 100% of the antibacterial properties are maintained. All medical articulated arms incorporate Microban. Microban is the world's leading provider of anti-bacterial solutions. It has been successfully applied for more than 35 years in a wide range of products used in the hospital, construction and food industries.

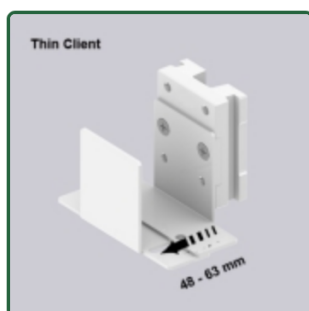
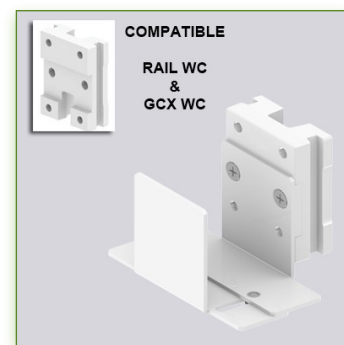
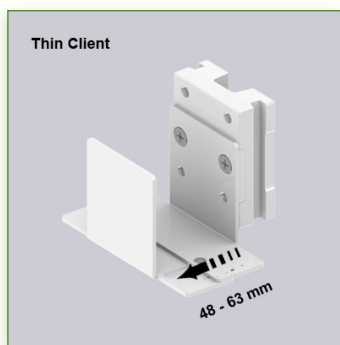
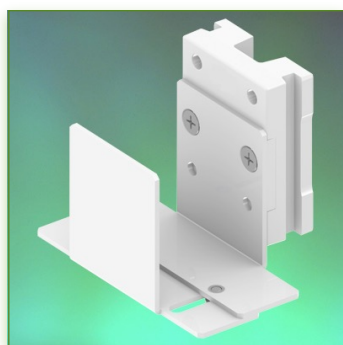

Universal Stand Adjustable
 48-63 mm mounting on Wall
 Rail
 Part Number: 999.164



Do not hesitate to contact us if you have any questions about this product.



Warranty: 5 years



000.999.164



Graphite Grey



On Measure



= Depending on the elements



999.164

Adjustable 48-63 mm Universal Holder on vertical sliding wall rail

This universal adjustable width and height support is suitable for the majority of small machines on the market.

It is coated with an anti-microbial agent offering hygiene and cleaning down to the last detail. Its modern design has been specially designed for healthcare environments.

Technical specifications:

* Optional Vertical Wall Rail Mounting, several lengths available (480 mm - 720 mm - 960 mm - 1200 mm).

These wall rails can be easily cut to the required size. All cables also pass through the wall rail.

* Optional mounting on worktop or floor or ceiling column, several heights of which are available:
 (300 mm - 500 mm - 1500 mm - 2000 mm)

* Adjustable in height according to the length of the wall rail

* Adjustable width from 48 to 63 mm

* Colour RAL 7024 (Graphite grey)

* All our medical arms are in conformity:
 CE, ROHS, Medical Grade, Regulations MDD 93/42 ECC.

* Warranty: 5 years

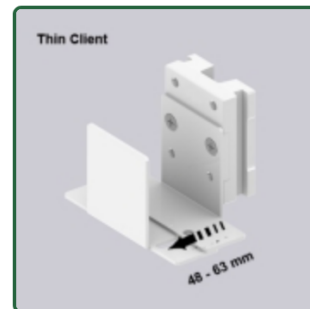
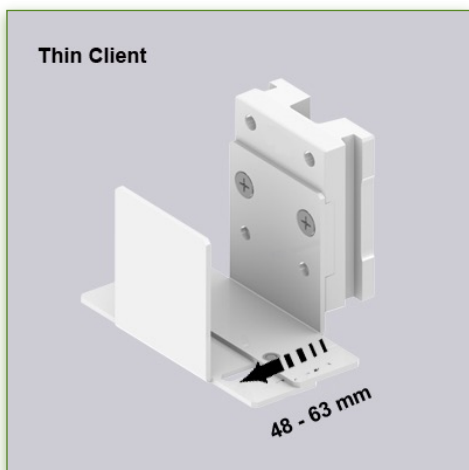
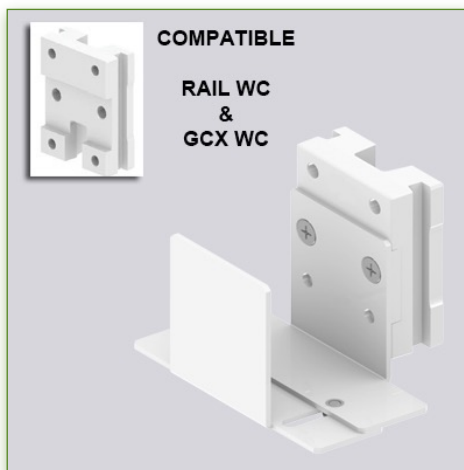
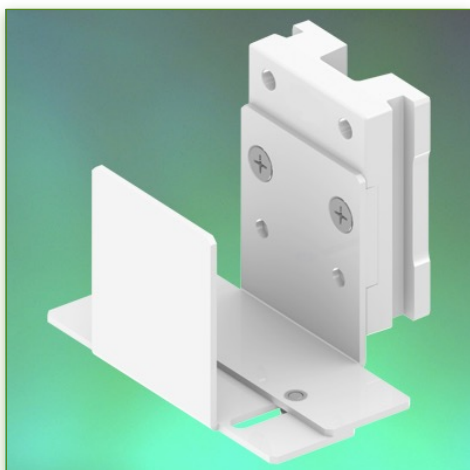

Universal Stand Adjustable
48-63 mm mounting on Wall
Rail
Part Number: 999.164



Do not hesitate to contact us if you have any questions about this product.



Warranty: 5 years



000.999.164



Graphite Grey



On Measure



= Depending on the elements



999.164

Anti-bacterial properties:

IT medical arms are now designed with Microban antibacterial protection, a revolutionary treatment that guarantees optimal hygiene. IT medical arms integrate Microban and other antibacterial agents into all medical products. It inhibits the growth of bacteria of all types. This is not a surface treatment.

It is 100% in the totality of the product. It does not alter the physico-mechanical properties of the medical arm lift system. Simulations over 30 years show that 100% of the antibacterial properties are maintained.

All medical articulated arms incorporate Microban. Microban is the world's leading provider of anti-bacterial solutions. It has been successfully applied for more than 35 years in a wide range of products used in the hospital, construction and food industries.

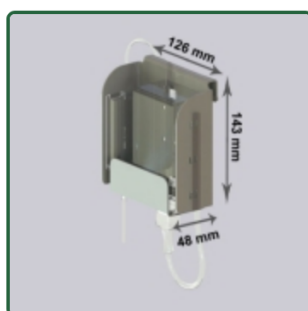
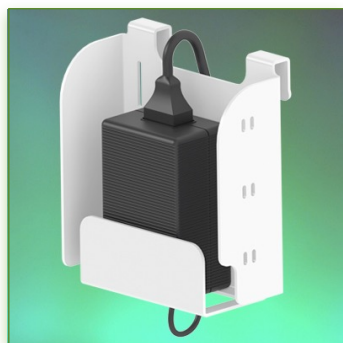

Power supply stand
Mounting on Wall Rail

Part Number: 999.165



Do not hesitate to contact us if you have any questions about this product.



Warranty: 5 years



000.999.165



Graphite Grey



On Measure



= Depending on the elements



999.165

Holder Power supply 126 x 143 48 mm Mounting on vertical sliding wall rail

Anodized aluminum power supply storage holder.

It is coated with an anti-microbial agent offering hygiene and cleaning down to the last detail. Its modern design has been specially designed for healthcare environments.

Technical specifications:

* Optional Vertical Wall Rail Mounting, several lengths available (480 mm - 720 mm - 960 mm - 1200 mm).

These wall rails can be easily cut to the required size. All cables also pass through the wall rail.

* Optional mounting on worktop or floor or ceiling column, several heights of which are available:
(300 mm - 500 mm - 1500 mm - 2000 mm)

* Suitable for most power supplies on the market

* Dimensions: 143 x 126 x 48 mm

* Colour RAL 7024 (Graphite grey)

* All our medical arms are in conformity:
CE, ROHS, Medical Grade, Regulations MDD 93/42 ECC.

* Warranty: 5 years

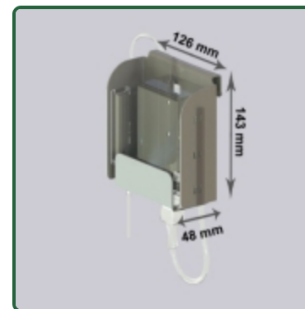
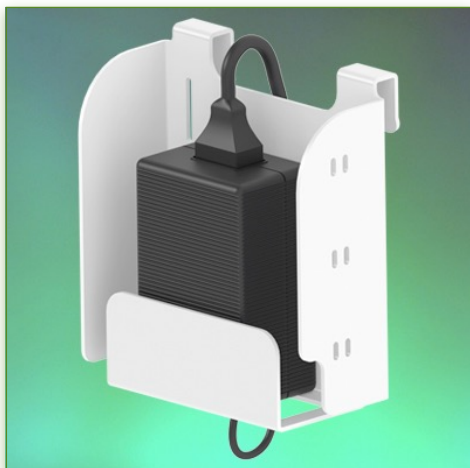

Power supply stand
 Mounting on Wall Rail

Part Number: 999.165



Medical Grade



Do not hesitate to contact us if you have any questions about this product.

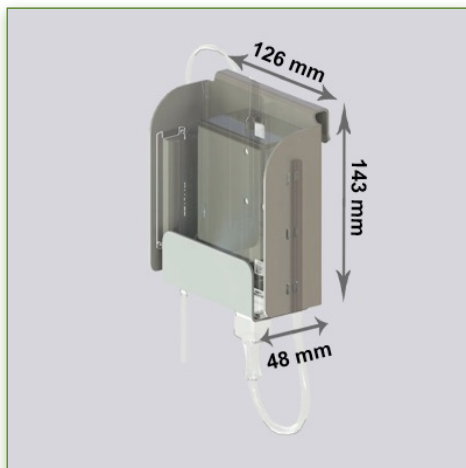

Warranty: 5 years



000.999.165



Graphite Grey



On Measure



= Depending on the elements



999.165

Anti-bacterial properties:

IT medical arms are now designed with Microban antibacterial protection, a revolutionary treatment that guarantees optimal hygiene. IT medical arms integrate Microban and other antibacterial agents into all medical products. It inhibits the growth of bacteria of all types. This is not a surface treatment.

It is 100% in the totality of the product.

It does not alter the physico-mechanical properties of the medical arm lift system. Simulations over 30 years show that 100% of the antibacterial properties are maintained.

All medical articulated arms incorporate Microban. Microban is the world's leading provider of anti-bacterial solutions. It has been successfully applied for more than 35 years in a wide range of products used in the hospital, construction and food industries.

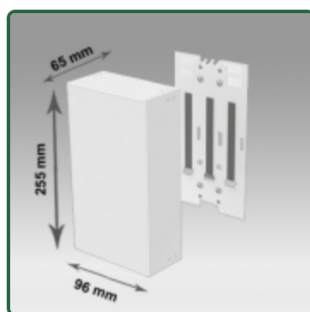
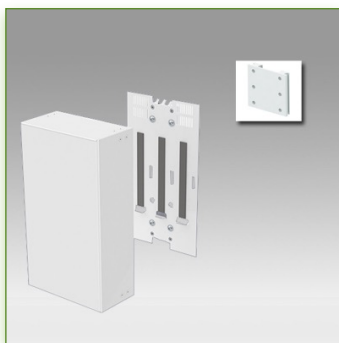
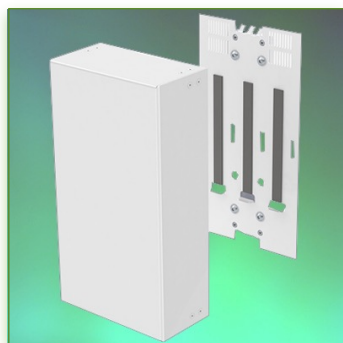

Electrical power supply box
255 x 96 x 65 mm
Mounting on Wall Rail
Part Number: 999.166



Do not hesitate to contact us if you have any questions about this product.



Warranty: 5 years



000.999.166



Graphite Grey



On Measure



= Depending on the elements



999.166

Power supply housing 255 x 96 x 65 mm Mounting on vertical sliding wall rail

Storage housing for power supply in anodised aluminium.

It is coated with an anti-microbial agent offering hygiene and cleaning down to the last detail. Its modern design has been specially designed for healthcare environments.

Technical specifications:

- * Optional Vertical Wall Rail Mounting, several lengths available (480 mm - 720 mm - 960 mm - 1200 mm). These wall rails can be easily cut to the required size. All cables also pass through the wall rail.
- * Optional mounting on worktop or floor or ceiling column, several heights of which are available: (300 mm - 500 mm - 1500 mm - 2000 mm)
- * Suitable for most power supplies on the market
- * Dimensions: 255 x 96 x 65 mm
- * Housing ventilated through ventilation holes to prevent overheating
- * Designed for one power supply
- * Colour RAL 7024 (Graphite grey)
- * All our medical arms are in conformity: CE, ROHS, Medical Grade, Regulations MDD 93/42 ECC.
- * Warranty: 5 years

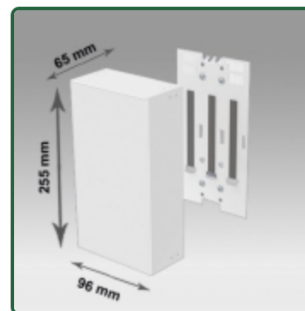
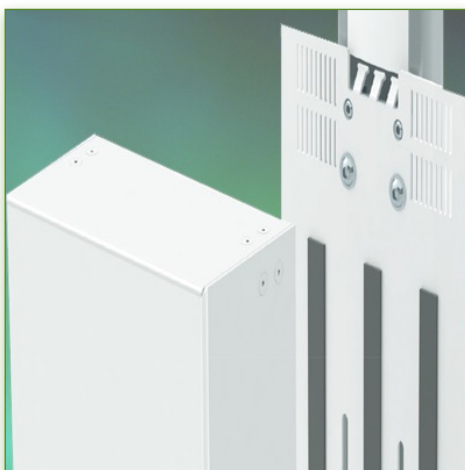
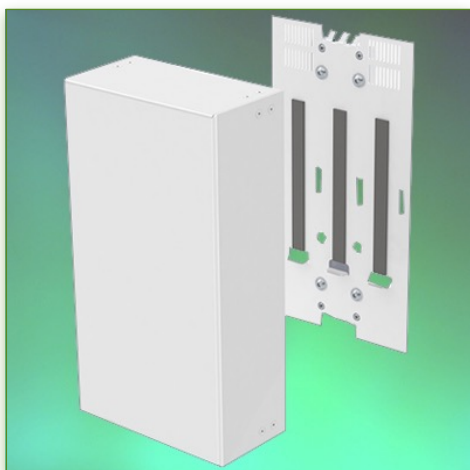

Electrical power supply box
 255 x 96 x 65 mm
 Mounting on Wall Rail
 Part Number: 999.166



Medical Grade



Do not hesitate to contact us if you have any questions about this product.



Warranty: 5 years



000.999.166



Graphite Grey



On Measure



= Depending on the elements



999.166

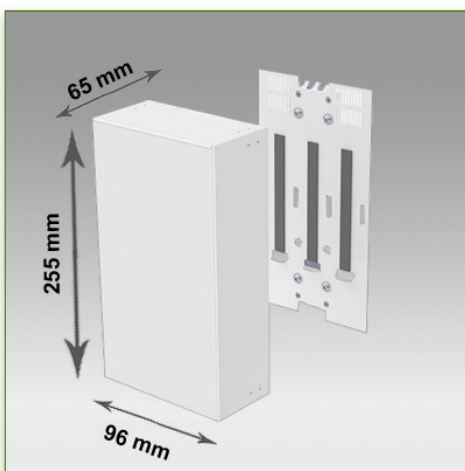
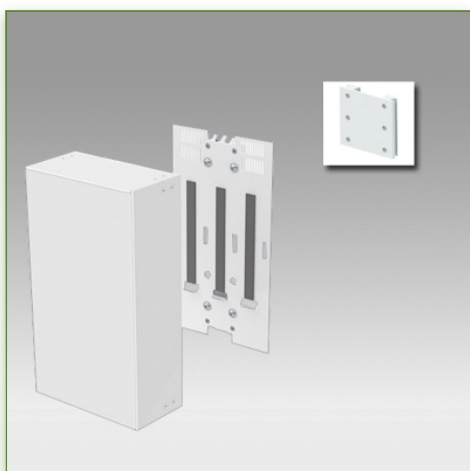

Anti-bacterial properties:

IT medical arms are now designed with Microban antibacterial protection, a revolutionary treatment that guarantees optimal hygiene. IT medical arms integrate Microban and other antibacterial agents into all medical products. It inhibits the growth of bacteria of all types. This is not a surface treatment.

It is 100% in the totality of the product. It does not alter the physico-mechanical properties of the medical arm lift system. Simulations over 30 years show that 100% of the antibacterial properties are maintained.

All medical articulated arms incorporate Microban. Microban is the world's leading provider of anti-bacterial solutions. It has been successfully applied for more than 35 years in a wide range of products used in the hospital, construction and food industries.

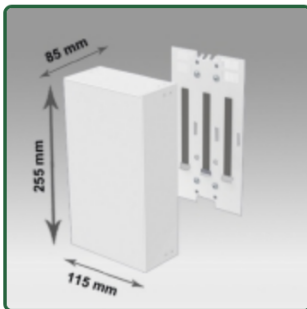
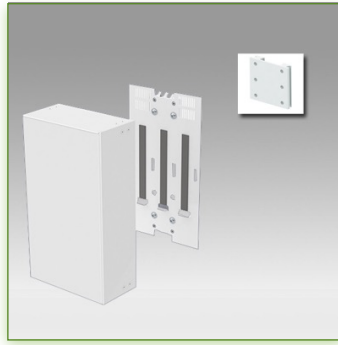
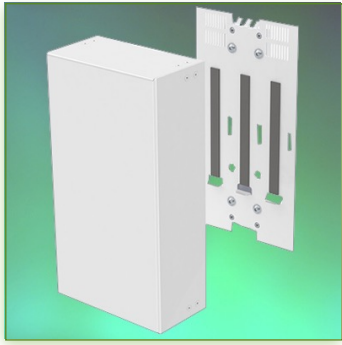

Electrical power supply box
255 x 115 x 85 mm
Mounting on Wall Rail
Part Number: 999.167



Do not hesitate to contact us if you have any questions about this product.



Warranty: 5 years



000.999.167



Graphite Grey



On Measure



= Depending on the elements



999.167

Power supply housing 255 x 115 x 85 mm Mounting on vertical sliding wall rail

Storage housing for power supply in anodised aluminium.

It is coated with an anti-microbial agent offering hygiene and cleaning down to the last detail. Its modern design has been specially designed for healthcare environments.

Technical specifications:

- * Optional Vertical Wall Rail Mounting, several lengths available (480 mm - 720 mm - 960 mm - 1200 mm). These wall rails can be easily cut to the required size. All cables also pass through the wall rail.
- * Optional mounting on worktop or floor or ceiling column, several heights of which are available: (300 mm - 500 mm - 1500 mm - 2000 mm)
- * Suitable for most power supplies on the market
- * Dimensions: 255 x 115 x 85 mm
- * Housing ventilated through ventilation holes to prevent overheating
- * Designed for one power supply
- * Colour RAL 7024 (Graphite grey)
- * All our medical arms are in conformity: CE, ROHS, Medical Grade, Regulations MDD 93/42 ECC.
- * Warranty: 5 years

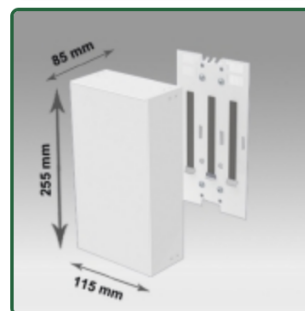
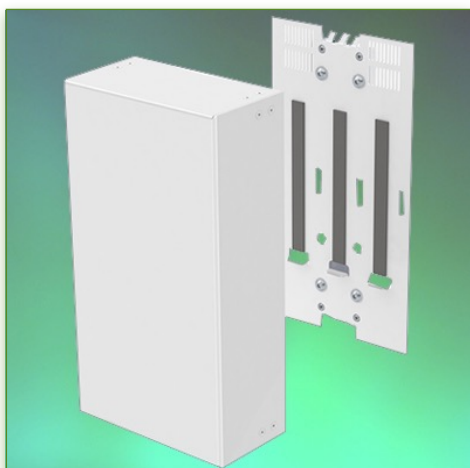

Electrical power supply box
255 x 115 x 85 mm
Mounting on Wall Rail
Part Number: 999.167



Medical Grade



Do not hesitate to contact us if you have any questions about this product.

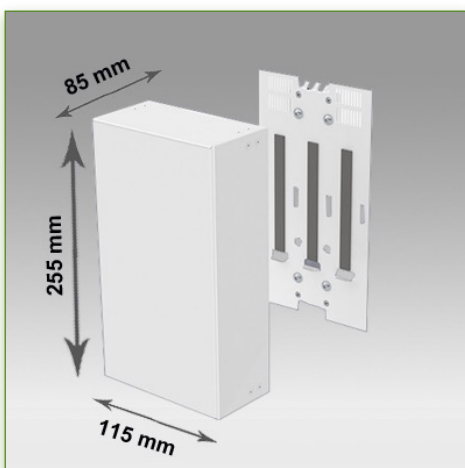
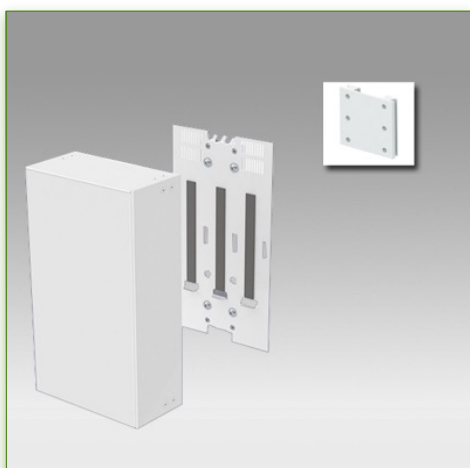

Warranty: 5 years



000.999.167



Graphite Grey



On Measure



= Depending on the elements



999.167

Anti-bacterial properties:

IT medical arms are now designed with Microban antibacterial protection, a revolutionary treatment that guarantees optimal hygiene. IT medical arms integrate Microban and other antibacterial agents into all medical products. It inhibits the growth of bacteria of all types. This is not a surface treatment.

It is 100% in the totality of the product.

It does not alter the physico-mechanical properties of the medical arm lift system. Simulations over 30 years show that 100% of the antibacterial properties are maintained.

All medical articulated arms incorporate Microban. Microban is the world's leading provider of anti-bacterial solutions. It has been successfully applied for more than 35 years in a wide range of products used in the hospital, construction and food industries.

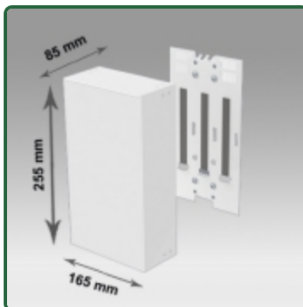
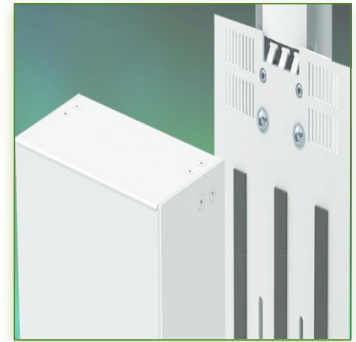
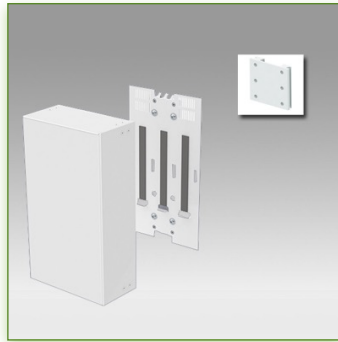
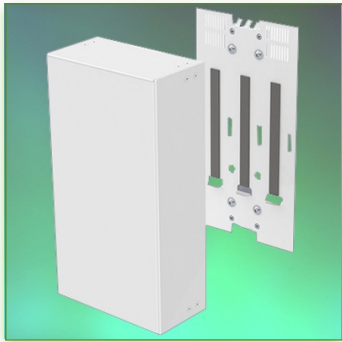

Electrical power supply box
255 x 165 x 85 mm
Mounting on Wall Rail
Part Number: 999.168



Do not hesitate to contact us if you have any questions about this product.



Warranty: 5 years



000.999.168



Graphite Grey



On Measure



= Depending on the elements



999.168

Power supply housing 255 x 165 x 85 mm Mounting on vertical sliding wall rail

Storage housing for power supply in anodised aluminium.

It is coated with an anti-microbial agent offering hygiene and cleaning down to the last detail. Its modern design has been specially designed for healthcare environments.

Technical specifications:

- * Optional Vertical Wall Rail Mounting, several lengths available (480 mm - 720 mm - 960 mm - 1200 mm). These wall rails can be easily cut to the required size. All cables also pass through the wall rail.
- * Optional mounting on worktop or floor or ceiling column, several heights of which are available: (300 mm - 500 mm - 1500 mm - 2000 mm)
- * Suitable for most power supplies on the market
- * Dimensions: 255 x 165 x 85 mm
- * Housing ventilated through ventilation holes to prevent overheating
- * Designed for one power supply
- * Colour RAL 7024 (Graphite grey)
- * All our medical arms are in conformity: CE, ROHS, Medical Grade, Regulations MDD 93/42 ECC.
- * Warranty: 5 years

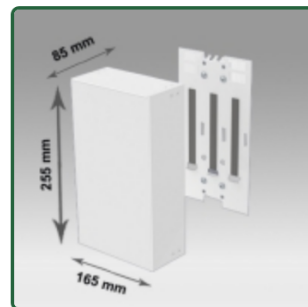
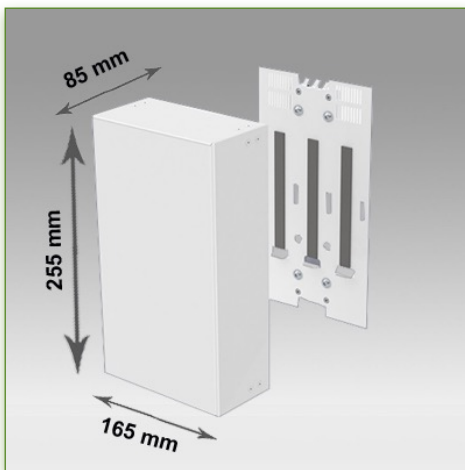
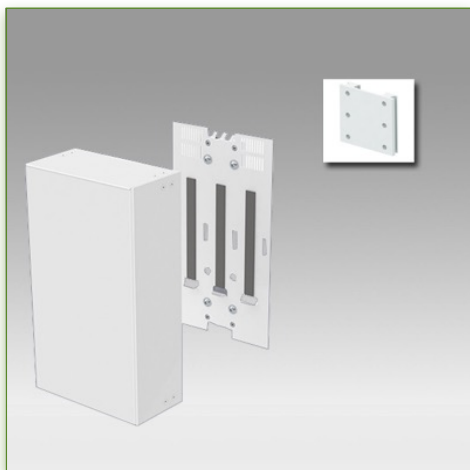
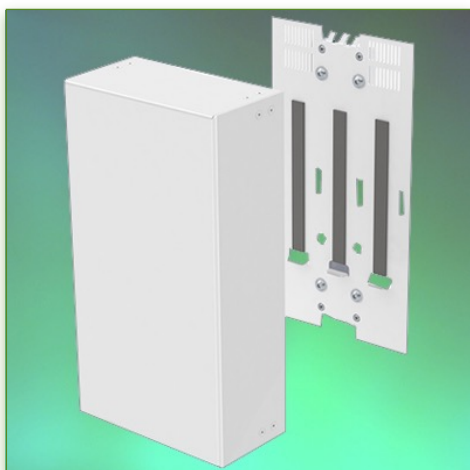

Electrical power supply box
255 x 165 x 85 mm
Mounting on Wall Rail
Part Number: 999.168



Medical Grade



Do not hesitate to contact us if you have any questions about this product.



Warranty: 5 years



000.999.168



Graphite Grey



On Measure



= Depending on the elements



999.168

Anti-bacterial properties:

IT medical arms are now designed with Microban antibacterial protection, a revolutionary treatment that guarantees optimal hygiene. IT medical arms integrate Microban and other antibacterial agents into all medical products. It inhibits the growth of bacteria of all types. This is not a surface treatment.

It is 100% in the totality of the product.

It does not alter the physico-mechanical properties of the medical arm lift system. Simulations over 30 years show that 100% of the antibacterial properties are maintained.

All medical articulated arms incorporate Microban. Microban is the world's leading provider of anti-bacterial solutions. It has been successfully applied for more than 35 years in a wide range of products used in the hospital, construction and food industries.

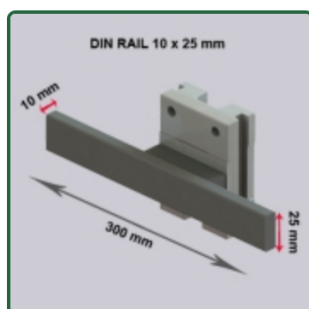
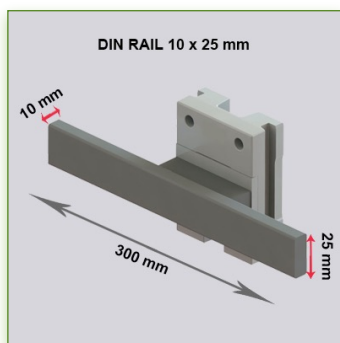
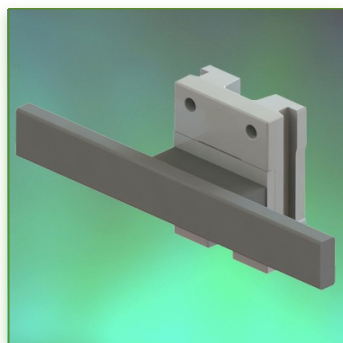

Din Rail 10 x 25 mm.
Length of 300 mm
Mounting on Wall Rail
Référence: 999.169



Do not hesitate to contact us if you have any questions about this product.



Warranty: 5 years



000.999.169



Graphite Grey



On Measure



= Depending on the elements



999.169

Din Rail adapter 10 x 25 mm. Length 300 mm Mounting on vertical sliding wall rail

This Din Rail Horizontal adapter allows the attachment of all medical accessories with the Din Rail 10 x 25 mm interface. Ideal complement when no Din Rails are available or absent to add other elements. It is coated with an anti-microbial agent offering hygiene and cleaning down to the last detail. Its modern design has been specially designed for healthcare environments.

Technical specifications:

* Optional Vertical Wall Rail Mounting, several lengths available (480 mm - 720 mm - 960 mm - 1200 mm).

These wall rails can be easily cut to the required size. All cables also pass through the wall rail.

* Optional mounting on worktop or floor or ceiling column, several heights of which are available:
(300 mm - 500 mm - 1500 mm - 2000 mm)

* Length 300 mm

* Din Rail 10 x 25 mm

* Colour RAL 7024 (Graphite grey)

* All our medical arms are in conformity:
CE, ROHS, Medical Grade, Regulations MDD 93/42 ECC.

* Warranty: 5 years

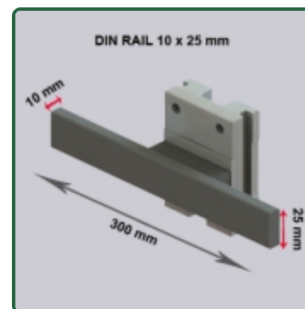
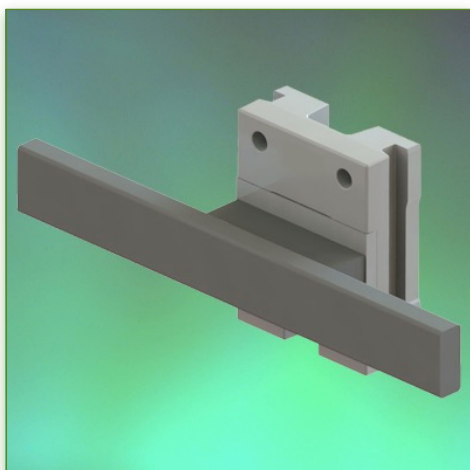

Din Rail 10 x 25 mm.
Length of 300 mm
Mounting on Wall Rail
Référence: 999.169



Do not hesitate to contact us if you have any questions about this product.

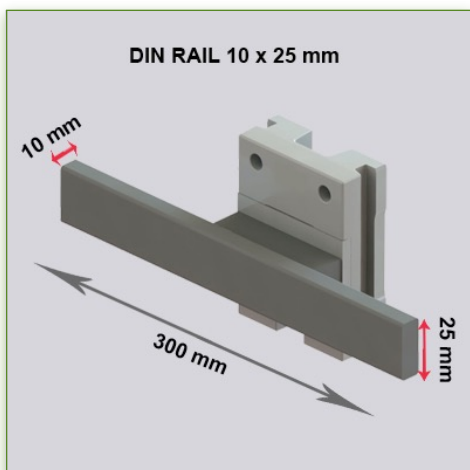

Warranty: 5 years

000.999.169

Graphite Grey

On Measure

= Depending on the elements

999.169

Anti-bacterial properties:

IT medical arms are now designed with Microban antibacterial protection, a revolutionary treatment that guarantees optimal hygiene. IT medical arms integrate Microban and other antibacterial agents into all medical products. It inhibits the growth of bacteria of all types. This is not a surface treatment. It is 100% in the totality of the product. It does not alter the physico-mechanical properties of the medical arm lift system. Simulations over 30 years show that 100% of the antibacterial properties are maintained. All medical articulated arms incorporate Microban. Microban is the world's leading provider of anti-bacterial solutions. It has been successfully applied for more than 35 years in a wide range of products used in the hospital, construction and food industries.

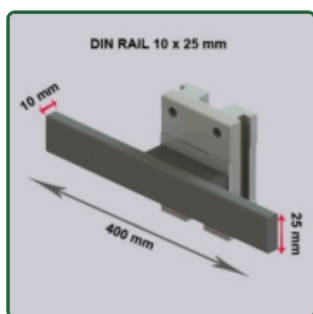
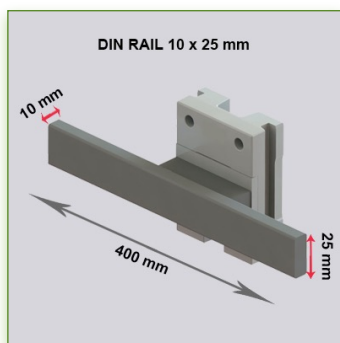
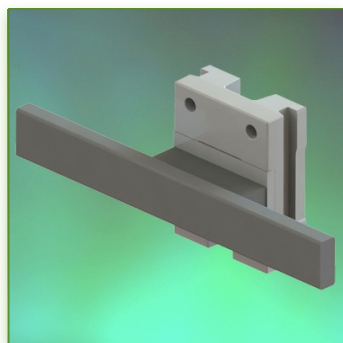

Din Rail 10 x 25 mm.
Length of 400 mm
Mounting on Wall Rail
Référence: 999.170



Do not hesitate to contact us if you have any questions about this product.



Warranty: 5 years



000.999.170



Graphite Grey



On Measure



= Depending on the elements



999.170

Din Rail adapter 10 x 25 mm. Length 400 mm Mounting on vertical sliding wall rail

This Din Rail Horizontal adapter allows the attachment of all medical accessories with the Din Rail 10 x 25 mm interface. Ideal complement when no Din Rails are available or absent to add other elements. It is coated with an anti-microbial agent offering hygiene and cleaning down to the last detail. Its modern design has been specially designed for healthcare environments.

Technical specifications:

* Optional Vertical Wall Rail Mounting, several lengths available (480 mm - 720 mm - 960 mm - 1200 mm).

These wall rails can be easily cut to the required size. All cables also pass through the wall rail.

* Optional mounting on worktop or floor or ceiling column, several heights of which are available:
(300 mm - 500 mm - 1500 mm - 2000 mm)

* Length 400 mm

* Din Rail 10 x 25 mm

* Colour RAL 7024 (Graphite grey)

* All our medical arms are in conformity:
CE, ROHS, Medical Grade, Regulations MDD 93/42 ECC.

* Warranty: 5 years

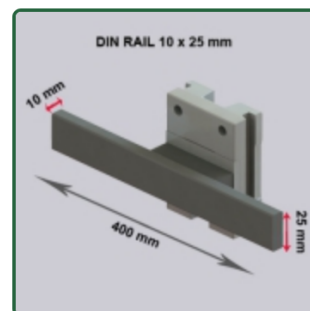
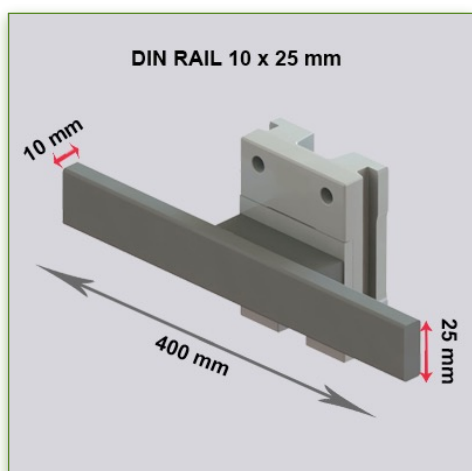
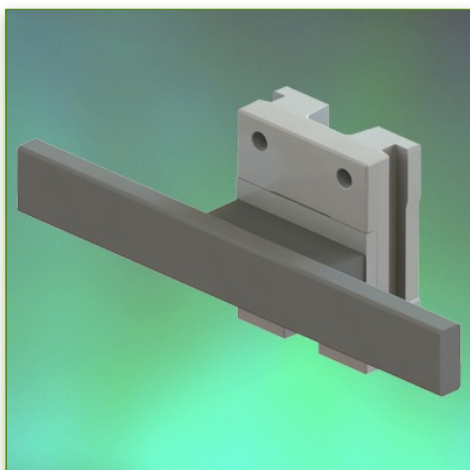

Din Rail 10 x 25 mm.
Length of 400 mm
Mounting on Wall Rail
Référence: 999.170



Medical Grade



Do not hesitate to contact us if you have any questions about this product.



Warranty: 5 years



000.999.170



Graphite Grey



On Measure



= Depending on the elements



999.170

Anti-bacterial properties:

IT medical arms are now designed with Microban antibacterial protection, a revolutionary treatment that guarantees optimal hygiene. IT medical arms integrate Microban and other antibacterial agents into all medical products. It inhibits the growth of bacteria of all types. This is not a surface treatment.

It is 100% in the totality of the product.

It does not alter the physico-mechanical properties of the medical arm lift system. Simulations over 30 years show that 100% of the antibacterial properties are maintained.

All medical articulated arms incorporate Microban.

Microban is the world's leading provider of anti-bacterial solutions. It has been successfully applied for more than 35 years in a wide range of products used in the hospital, construction and food industries.

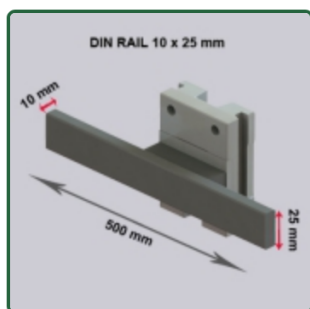
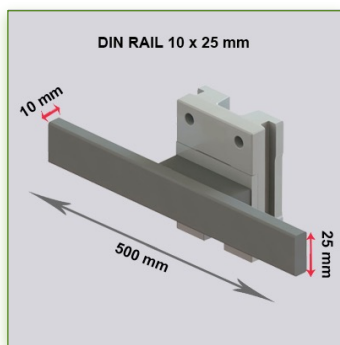
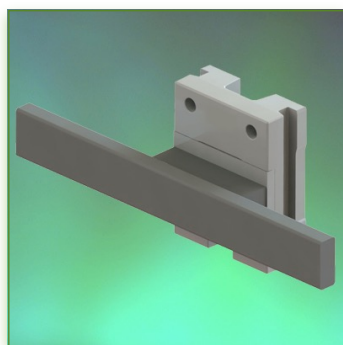

Din Rail 10 x 25 mm.
Length of 500 mm
Mounting on Wall Rail
Référence: 999.171



Do not hesitate to contact us if you have any questions about this product.



Warranty: 5 years



000.999.171



Gris graphite



On Measure



= Depending on the elements



999.171

Din Rail adapter 10 x 25 mm. Length 500 mm Mounting on vertical sliding wall rail

This Din Rail Horizontal adapter allows the attachment of all medical accessories with the Din Rail 10 x 25 mm interface. Ideal complement when no Din Rails are available or absent to add other elements. It is coated with an anti-microbial agent offering hygiene and cleaning down to the last detail. Its modern design has been specially designed for healthcare environments.

Technical specifications:

* Optional Vertical Wall Rail Mounting, several lengths available (480 mm - 720 mm - 960 mm - 1200 mm).

These wall rails can be easily cut to the required size. All cables also pass through the wall rail.

* Optional mounting on worktop or floor or ceiling column, several heights of which are available:
(300 mm - 500 mm - 1500 mm - 2000 mm)

* Length 500 mm

* Din Rail 10 x 25 mm

* Colour RAL 7024 (Graphite grey)

* All our medical arms are in conformity:
CE, ROHS, Medical Grade, Regulations MDD 93/42 ECC.

* Warranty: 5 years

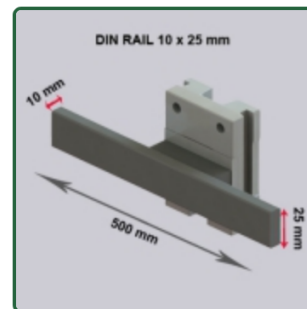
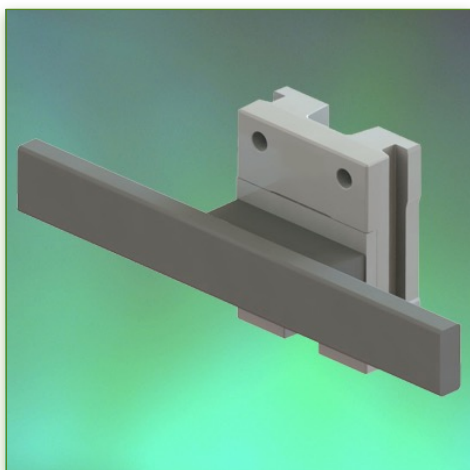

Din Rail 10 x 25 mm.
Length of 500 mm
Mounting on Wall Rail
Référence: 999.171



Medical Grade



Do not hesitate to contact us if you have any questions about this product.



Warranty: 5 years



000.999.171



Gris graphite



On Measure



= Depending on the elements



999.171

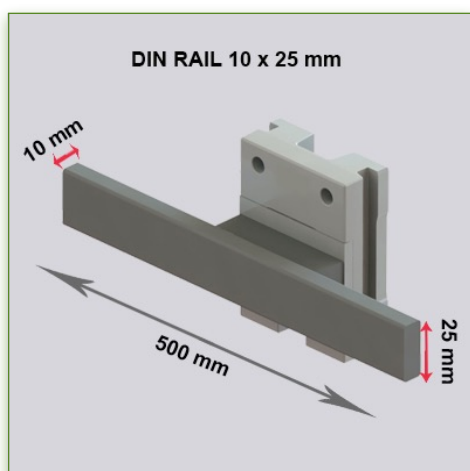

Anti-bacterial properties:

IT medical arms are now designed with Microban antibacterial protection, a revolutionary treatment that guarantees optimal hygiene. IT medical arms integrate Microban and other antibacterial agents into all medical products. It inhibits the growth of bacteria of all types. This is not a surface treatment.

It is 100% in the totality of the product.

It does not alter the physico-mechanical properties of the medical arm lift system. Simulations over 30 years show that 100% of the antibacterial properties are maintained.

All medical articulated arms incorporate Microban. Microban is the world's leading provider of anti-bacterial solutions. It has been successfully applied for more than 35 years in a wide range of products used in the hospital, construction and food industries.



Holder for 1 Bottle of Medical Gas
Mounting on Wall Rail
Référence: 999.172



Do not hesitate to contact us if you have any questions about this product.



Warranty: 5 years



000.999.172



Graphite Grey



On Measure



= Depending on the elements



999.172

Holder for 1 Bottle of Medical Gas Mounted on vertical wall rail

This holder is specifically designed for standardised medical gas bottles in hospitals. For the safe installation of pressurized gas bottles It is coated with an anti-microbial agent offering hygiene and cleaning down to the last detail. Its modern design has been specially designed for healthcare environments.

Technical specifications:

- * Optional Vertical Wall Rail Mounting, several lengths available (480 mm - 720 mm - 960 mm - 1200 mm). These wall rails can be easily cut to the required size. All cables also pass through the wall rail.
- * Optional mounting on worktop or floor or ceiling column, several heights of which are available: (300 mm - 500 mm - 1500 mm - 2000 mm)
- * Safely holds the bottle in an upright position
- * Priming and defusing, gas bottle with safety clips
- * Securely stows bottles while providing ease of use for the user when changing bottles.
- * Suitable for one gas bottle
- * Colour RAL 7024 (Graphite grey)
- * All our medical arms are in conformity: CE, ROHS, Medical Grade, Regulations MDD 93/42 ECC.
- * Warranty: 5 years



Holder for 1 Bottle of Medical Gas
Mounting on Wall Rail
Référence: 999.172



Medical Grade



Do not hesitate to contact us if you have any questions about this product.



Warranty: 5 years



000.999.172



Graphite Grey



On Measure



= Depending on the elements



999.172

Anti-bacterial properties:

IT medical arms are now designed with Microban antibacterial protection, a revolutionary treatment that guarantees optimal hygiene. IT medical arms integrate Microban and other antibacterial agents into all medical products. It inhibits the growth of bacteria of all types. This is not a surface treatment.

It is 100% in the totality of the product.

It does not alter the physico-mechanical properties of the medical arm lift system. Simulations over 30 years show that 100% of the antibacterial properties are maintained.

All medical articulated arms incorporate Microban. Microban is the world's leading provider of anti-bacterial solutions. It has been successfully applied for more than 35 years in a wide range of products used in the hospital, construction and food industries.



Holder for 2 Medical Gas
 Bottles
 Mounting on Wall Rail
 Part Number: 999.173



Do not hesitate to contact us if you have any questions about this product.



Warranty: 5 years



000.999.173



Graphite Grey



On Measure



= Depending on the elements



999.173

Holder for 2 Bottles of Medical Gas Mounted on vertical wall rail

This holder is specifically designed for standardised medical gas bottles in hospitals. For the safe installation of pressurized gas bottles It is coated with an anti-microbial agent offering hygiene and cleaning down to the last detail. Its modern design has been specially designed for healthcare environments.

Technical specifications:

- * Optional Vertical Wall Rail Mounting, several lengths available (480 mm - 720 mm - 960 mm - 1200 mm). These wall rails can be easily cut to the required size. All cables also pass through the wall rail.
- * Optional mounting on worktop or floor or ceiling column, several heights of which are available: (300 mm - 500 mm - 1500 mm - 2000 mm)
- * Safely holds the bottle in an upright position
- * Priming and defusing, gas bottle with safety clips
- * Securely stows bottles while providing ease of use for the user when changing bottles.
- * Suitable for two gas bottles
- * Colour RAL 7024 (Graphite grey)
- * All our medical arms are in conformity: CE, ROHS, Medical Grade, Regulations MDD 93/42 ECC.
- * Warranty: 5 years



Holder for 2 Medical Gas
 Bottles
 Mounting on Wall Rail
 Part Number: 999.173



Medical Grade



Do not hesitate to contact us if you have any questions about this product.



Warranty: 5 years



000.999.173



Graphite Grey



On Measure



= Depending on the elements



999.173

Anti-bacterial properties:

IT medical arms are now designed with Microban antibacterial protection, a revolutionary treatment that guarantees optimal hygiene. IT medical arms integrate Microban and other antibacterial agents into all medical products. It inhibits the growth of bacteria of all types. This is not a surface treatment.

It is 100% in the totality of the product.

It does not alter the physico-mechanical properties of the medical arm lift system. Simulations over 30 years show that 100% of the antibacterial properties are maintained.

All medical articulated arms incorporate Microban. Microban is the world's leading provider of anti-bacterial solutions. It has been successfully applied for more than 35 years in a wide range of products used in the hospital, construction and food industries.

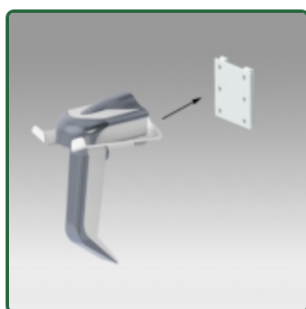
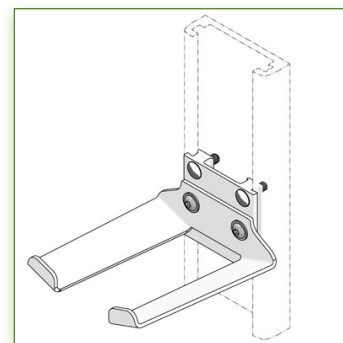
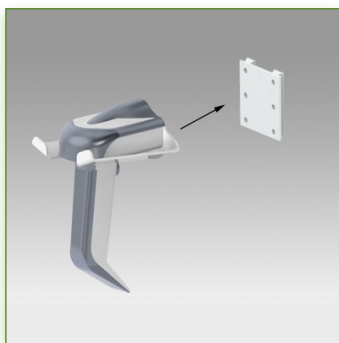

Holder for barcode hand shower
 Mounting on Wall Rail
 Part Number: 999.174



Do not hesitate to contact us if you have any questions about this product.



Warranty: 5 years



000.999.174



Graphite Grey and White



On Measure



= Depending on the elements



999.174

Universal Hand Shower Barcode Holder Wall Mount

Universal barcode hand shower holder ideal for keeping the hand shower close to the medical facility. This 13.5 x 10.31 x 6 cm barcode reader holder can be attached along the vertical wall rail

This rugged barcode scanner stand is the perfect storage or scanning application.

Color: Graphite Grey and White

Technical specifications:

* Optional Vertical Wall Rail Mounting, several lengths available (480 mm - 720 mm - 960 mm - 1200 mm).

These wall rails can be easily cut to the required size. All cables also pass through the wall rail.

* Optional mounting on worktop or floor or ceiling column, several heights of which are available: (300 mm - 500 mm - 1500 mm - 2000 mm)

* Keeps the hand shower safe

* All our medical arms are in conformity: CE, ROHS, Medical Grade, Regulations MDD 93/42 ECC.

* Warranty: 5 years

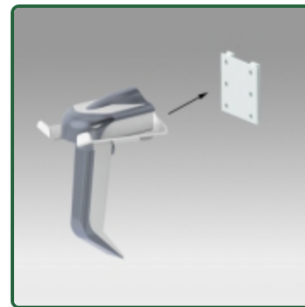
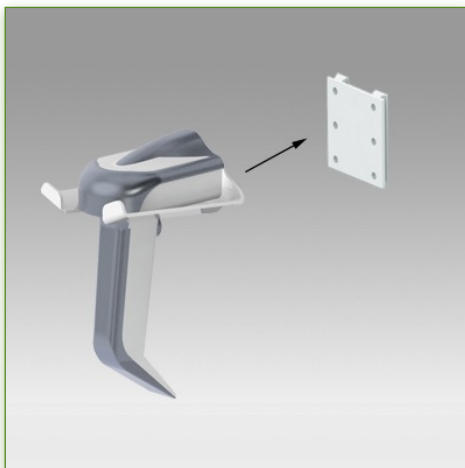

Holder for barcode hand shower
 Mounting on Wall Rail
 Part Number: 999.174



Medical Grade



Do not hesitate to contact us if you have any questions about this product.

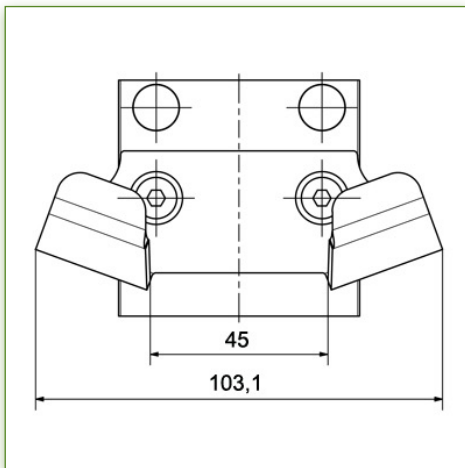
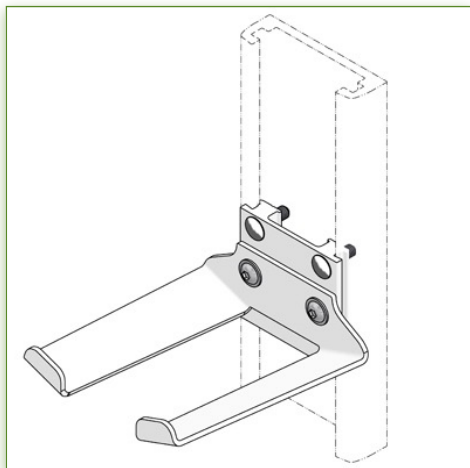

Warranty: 5 years



000.999.174



Graphite Grey and White



On Measure



= Depending on the elements



999.174

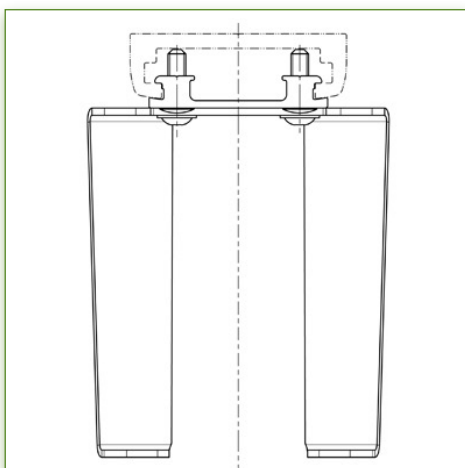
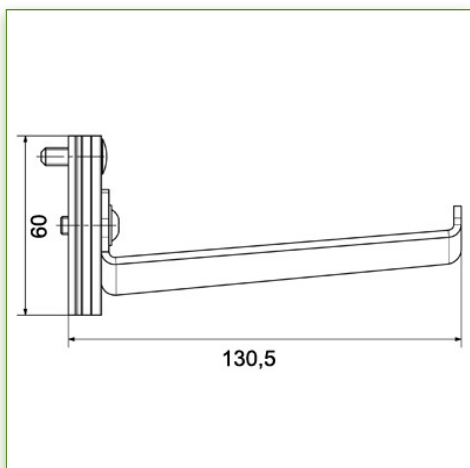

Anti-bacterial properties:

IT medical arms are now designed with Microban antibacterial protection, a revolutionary treatment that guarantees optimal hygiene. IT medical arms integrate Microban and other antibacterial agents into all medical products. It inhibits the growth of bacteria of all types. This is not a surface treatment.

It is 100% in the totality of the product. It does not alter the physico-mechanical properties of the medical arm lift system. Simulations over 30 years show that 100% of the antibacterial properties are maintained.

All medical articulated arms incorporate Microban. Microban is the world's leading provider of anti-bacterial solutions. It has been successfully applied for more than 35 years in a wide range of products used in the hospital, construction and food industries.

Médical Grade

Innovative designs, a StS® shortened elevator technology with a factor 6 gas lift that makes computer medical elevation effortlessly unmatched in the industry.

This StS® technology offers smooth adjustment flexibility regardless of the size and strength of the user, allowing him to maximize his comfort of use both sitting and standing. The revolutionary design of the StS technology separates from conventional technologies that do not meet the safety factor standards generally used in this type of design.

A StS elevator technology that is not under pressure, which means that your long-term performance will remain higher.

Designed for prolonged sitting or permanent applications. The StS technology offers a true revolution in ergonomic design that can be used by a wide range of clinicians and caregivers of all sizes, allowing them to adjust the height of the medical arm.

Robust, anodized aluminum construction, complemented by a small footprint, makes computer medical arms accessible even in places where space is at a premium.

These computerized medical workstations contribute to the encoding of critical patient care information with comfort at the patient's bedside with unmatched travel comfort.

Computerized medical arms comply with hospital hygiene standards, effectively they contain less than 5% of plastic harmful to bacteria and can be disinfected in the smallest details.

An anti-bacterial coating (microban) ensures perfect hygiene of arms and all parts are therefore impermeable to bacteria, no asperities in their designs aimed at a complete cleaning, fast and easy, helping to control infections.

It takes only 10 minutes to completely disinfect the workstation.

Human-centered designs place mobile computing exactly where it needs to be, reducing the time spent on each task for more efficiency.

the fruit of a close collaboration with the nurses, the computer scientists, the doctors, offering them a comfort and an ergonomics unparalleled in the data entry.

These medical computer arm solutions offer healthy computing environments that promote work efficiency.

Developed for superior performance, quality, durability for a better return on investment. Designed and created to minimize the impact of energy consumption and thereby reduce the harmful effects of air emissions and pollution.

Backed by a 5 year warranty, our solutions will give you all satisfactions.

An Exceptional Experience! "Often copied, never equaled"

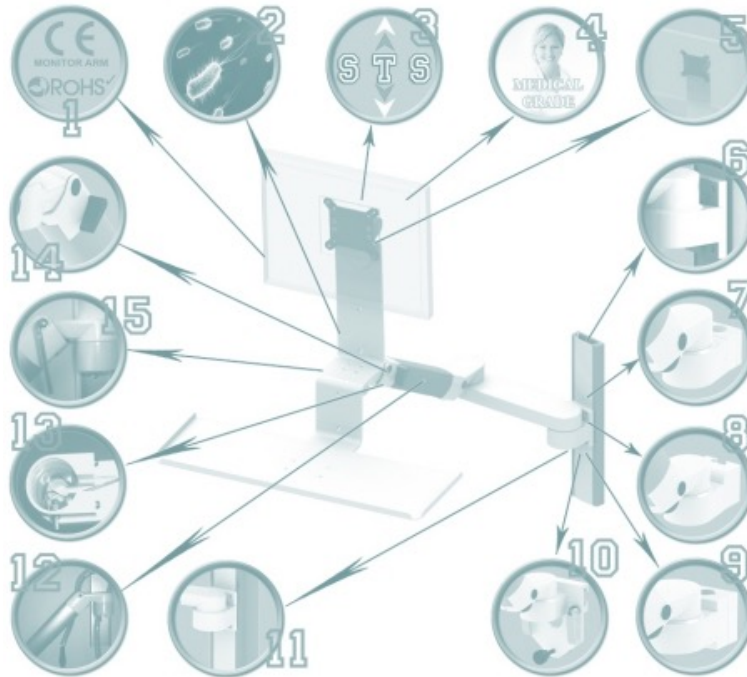

Unmatched in technology, comfort and installation

- 1 / Compliant and CE and ROHS / DIN EN ISO 9001: 2008 certified
- 2 / Anti-bacterial coating
- 3 / Height adjustable technology
- 4 / Medical Standards
- 5 / VESA 75 and 100 mm
- 6 / Possibility of mounting on Din Wall Rail optional
- 7 / Possibility of mounting on fixed pole, 25 - 35 - 38 mm
- 8 / Possibility of mounting on Din Vertical Rail 10 x 25 mm
- 9 / Possibility of mounting on variable pole between 20 and 40 mm
- 10 / Possible installation on DIN Rail Horizontal, 10 x 25 - 8 x 35 - 10 x 30 - 10 x 50 mm
- 11 / Optional column mounting option
- 12 / Cable entry and internal connector on the arm (internal chute supplied)
- 13 / Equipotential bonding and connector
- 14 / Adjustment and safety lever
- 15 / Adjustment and easy control of the gas cylinder

Bacteria-proof

Plastic, even food, is porous. This porosity, accentuated by scratches can cause bacteria nests in computerized medical arms during these constant manipulations. A biofilm can be put in place in a few hours, and allow the bacteria there to become resistant to external agents.

This is why our Computer Medical Arms, contrary to what we find on the market have a complete structure in anodized aluminum. Less than 5% of plastic in their designs dedicated specifically to the medical and hospital sector.

Aluminum, its characteristics, its properties, its utility:

Main characteristics

Density: 2700 kg / m³

Density: 2.7 (three times less than steel)

The use of aluminum is therefore essential in the areas of the construction of our computer arms.

Corrosion resistance:

Aluminum alloys are highly oxidizable. In the air, a layer of a few micrometers of aluminum oxide (Al₂O₃) is formed. Thanks to this thin film, aluminum alloys become resistant to corrosion. Unlike most metals, aluminum needs to oxidize to be used. Without this film of oxide, it would be unsuitable for most of its applications.

Thus, under normal atmospheric conditions, exterior building claddings or aluminum alloy parts have minimal maintenance and extended service life.

Anodizing:

Forced oxidation with an electrolyte makes it possible to obtain coloring of the parts. This anodizing can also be colorless to keep the shine of the pieces (aluminum color). The protective oxide layer can be made thicker by anodization.

Recycling:

To recycle aluminum, there is nothing simpler: just melt it. In addition to environmental benefits, aluminum recycling is much less expensive than extraction from bauxite ore. It requires 95% less energy. And a ton of recycled aluminum saves four tons of bauxite. By skipping the electrolysis stage, which requires a lot of energy, we avoid the pollutant emissions associated with it. Aluminum is almost infinitely recyclable without losing its qualities. In France, aluminum is recovered as part of selective sorting. In sorting centers, it is sorted thanks to eddy currents. It is then broken and crushed and melted. The downside, aluminum remains on the market an expensive material.

Benefit:

- * Resistant to corrosion
- * Unalterable color
- * Rigid
- * Allows 100% recycling
- * Light
- * Noise and vibration reduction
- * Do not rust
- * Longevity is three to four times greater than steel
- * Absorbs considerable pressure and effort
- * Insulation
- * Effective barrier against bacteria
- * Raincoat
- * Resistant to high and low temperatures
- * Sterilizable
- * Strength, weight, versatility
- * Do not burn
- * Anti acid

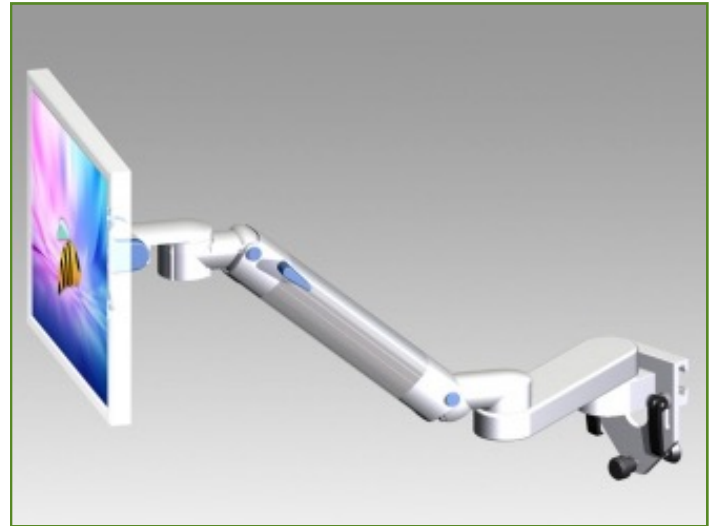
**Antibacterial Micoban:**

The medical computer arms are now designed with Microban antibacterial protection, a revolutionary treatment that guarantees optimal hygiene. Medical computer arms integrate Microban and other anti-bacterial agents into all medical products. It inhibits the growth of bacteria of all types. It is not a superficial treatment. It is 100% in the entire product. It does not entail any alteration of the physico-mechanical properties of the lift system of the medical arms. 30-year simulations show that 100% of anti-bacterial properties are maintained. All medical articulated arms incorporate Microban. Microban is a world leader in anti-bacterial solutions. It has been successfully applied for more than 35 years in multiple products used in the hospital, construction and food sectors.

Safety factor - Load with sixfold safety factor

The factor of safety is the use of more elements than necessary to compensate for the effects of unknown variables and to prevent system failures.

Design requires dealing with the unknown. Whatever the designer's level of knowledge and the quality of the specifications, hypotheses are inevitable in any design process.

The safety factors are used to offset the potential effects of these unknowns. The idea is to add materials and components to the system so that the design exceeds the specifications defined as necessary to meet the needs.

For example, designing an internet service that can support thousands of users is straightforward and straightforward. However, to take into account unanticipated needs for example downloading large files, the specifications of the need can be multiplied (here in threes).

In this case, the safety factor of three means that the service is qualified as being able to support 1000 users but is designated to actually support 3000.

The level of the safety factor corresponds directly to the level of ignorance of the design parameters. The higher the level of ignorance, the more the safety factor will be increased. More elements mean a higher cost.

The novelties require an important factor of safety. If a design becomes reliable over time, the confidence that the unknowns of the system disappear combined with the pressure to reduce costs causes a process of trimming and reducing the factor of safety.

Unfortunately, this process usually continues until an accident or malfunction occurs.

The safety factor must be used to minimize the risk of design failure. When the level of confidence in the design increases, we can then decrease the coefficient of safety but we must be careful not to go too far.

It is necessary to observe the nominal capacity of a system to make decisions that stress the limits of the system and not the expected capacity.

That is why all our medical arms are certified with a safety factor of 6 for your safety and that of your patients.



Disinfection, cleaning and hygiene of medical arms

Innovative designs, a StS® shortened lift technology with a factor 6 gas jack that allows the arms Hospital-acquired infections are a real public health problem. There are nowadays in France, about 10,000 deaths per year of these infections contracted at the hospital. They represent a very heavy burden for society, from a human, economic and social point of view. As a result, medical computer trolleys have been designed to be disinfected in their totality and disinfection takes only a very short time for the hygienist (less than 10 minutes).

WHY KEEP THE SAFE SURFACES?

- * Pathogenic microorganisms that enter the premises can survive on surfaces for long periods of time. periods of time.
- * Microorganisms that settle on surfaces can then be transmitted to the hands.
- * The germs of the hands can spread by contact, and be transmitted to other people and cause an infection.
- * Clean or disinfect surfaces to reduce the risk of cross-contamination.
- * Clean water may become contaminated if its container is not clean.

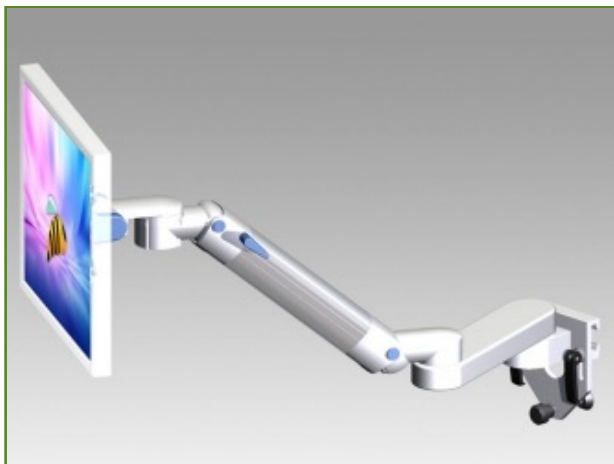

Recommended disinfectants:

1. Chlorine-based (10% max solution) - Chlorox, Novalsan, etc.
2. Formaldehyde base - 37% formaldehyde solution, Vinco Formaldegen, etc.
3. Glutaraldehyde-based stock - Aldacide 200, Lysofume, Wavicide, etc.
4. Phenol stock base - Lysol IC, many, Magna Clean, Tek-Trol, etc.
5. Alcohol Based - CaviCide, Isopropyl Alcohol, Medicide (POL-0.3), etc.
6. Oxidants - Hydrogen Peroxide Solution 3%, VikronS, Lifegard series, etc.
7. Ammonium quaternaries - Roccal-D, Bacto-Sep, Ascend, Parvosol, etc.
8. Soap and hot water

DO NOT USE:

1. Oil-based liquid cleaners, such as gasoline, turpentine or petroleum
2. Acetone
3. More than 10% bleach solutions
4. Temperature or sterilization pressure

Ergonomics of workstations on screen

Determination of posture

A good design of an on-screen workstation allows:

- * increase the postural margin of the operator; any posture, however ideal, becoming uncomfortable after a certain time (pain in the shoulders, arms, hands, neck, back and legs),
- * to reduce the stresses of the cervical vertebrae and the muscles supporting the head (cervicalgia, muscular fatigue),
- * * to reduce the disorders due to a sustained cognitive and visual activity (headache, tingling, tearing, visual discomfort, etc.),
- * to increase blood circulation in the legs, ...

Follow these two steps to improve the comfort of your workstation:

1. Select your size (in cm):

Size in cm	Eyes in a sitting position	Eyes in a standing position	Elbow in sitting position	Elbow in Standing Position	Armchair
152	105	141	57	93	36
155	107	144	58	94	37
157	110	146	59	95	38
160	111	148	60	97	38
163	113	151	61	99	39
165	115	153	62	101	40
168	117	156	63	102	41
170	118	158	64	104	41
173	120	161	65	106	42
175	122	163	66	108	43
178	124	166	67	109	44
180	125	168	68	111	44
183	127	171	68	112	46
185	129	173	69	113	46
188	131	175	72	116	48
191	133	178	72	117	48

2. Install / adjust the workstation components as described below:

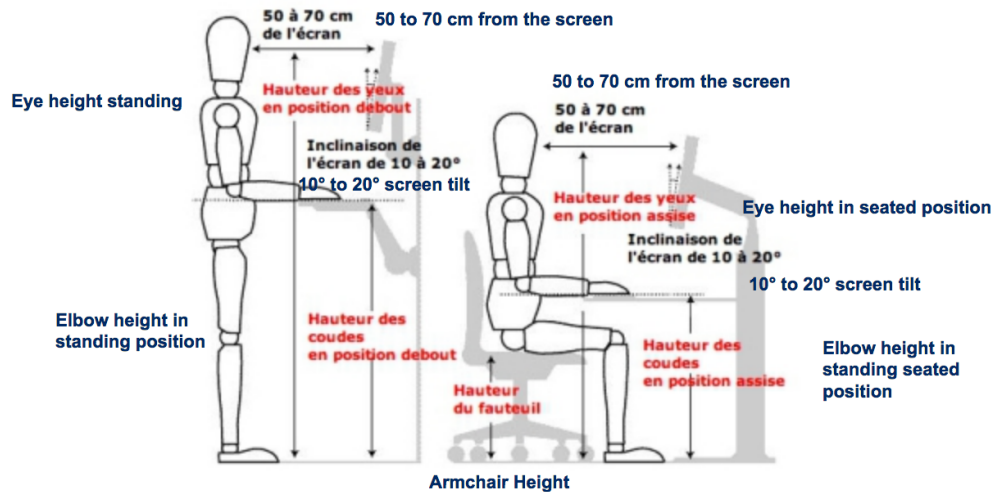

Positions

The eyes should be aligned with the top of the display surface of the screen (specifically, the center of the screen should be at an angle of 15 degrees to the horizontal at eye level).

Exception: For wearers of progressive lenses, lower the monitor and tilt the screen up to avoid neck pain.

The height of the elbows should be adjusted with the top of the keyboard.

The height of the chair should help to keep the feet flat when the hips are at a 90 ° angle.

A seat slightly inclined downward (3 to 5 degrees) allows to better respect the natural curvature of the spine in double "S", which relieves the lumbar vertebrae.

Remarks

These values do not take into account the clothing elements. Remember to add the height of the shoes to make the right measurements.

Remember that no posture can be preserved for a long time, the postural margin being a fundamental element of comfort.

Beyond its standard recommendations, it is important to consider the location of the various elements at the station, the characteristics and distribution of the various tasks, the environmental context (thermal, acoustic and luminous environment), the collective context of the activity. (stress, mutual assistance, conflicting injunctions, etc.) and any particularities or restrictions of aptitude of the operator concerned.

Be careful not to make the mistake (made by both the operators and the companies specialized in tertiary installations) to position the screen face or back to the window but perpendicular to avoid direct glare (sometimes effective but not perceived) or the reflections of the screen.



**FOLDABLE COMBO MEDICAL ARMS
FOR DISPLAY, KEYBOARD AND MOUSE
WALL MOUNTING**



We have all the solutions and offer you the widest choice of professional medical systems and supports compatible with the widest possible range of medical displays and keyboards.